



SUNFLOWER ELECTRIC POWER CORPORATION

20170918140158
Filed Date: 09/18/2017
State Corporation Commission
of Kansas

September 18, 2017

Via: KCC E-Filing Express

Amy L. Green
Secretary to the Commission
Kansas Corporation Commission 1500 SW Arrowhead Road
Topeka, Kansas 66604

Re: Docket No. 14-SEPE-220-TFR – Annual Update Filing

Dear Ms. Green:

Sunflower Electric Power Corporation, (“Sunflower”) submits its populated formula rate template for electronic filing in the above-referenced docket. The populated formula rate template consists of 2016 actual data which is used to project transmission revenue requirements for the 2018 rate year. Also attached is the Summary of Projected Transmission Facilities Exceeding \$5 million.

This filing is being made pursuant to the Protocols contained in Sunflower’s Open Access Transmission Tariff (“OATT”), Attachment H, Appendix B, as approved by the Kansas Corporation Commission on October 31, 2013, in Docket No. 13-SEPE-701-TAR.

Per the Sunflower OATT Protocols, Sunflower will conduct a customer meeting with its zonal transmission customers on September 28, 2017, to review the filing.

Thank you for your assistance and please feel free to contact me with any questions or concerns.

Sincerely,

James Brungardt
Manager, Regulatory Relations

Encl. 2

Sunflower Electric Power Corporation (SEPC)
Rate Formula Template
Table of Contents

Overview

The formula is calculated in two steps. The first step is to fill out Tabs A-1 thru A-11, and the Actual Gross Rev Req tab with data from the previous year's KCC Annual Report. This data input results in the calculation of the actual annual transmission revenue requirement (Actual ATRR) for the previous year, as shown in the Actual Net Rev Req tab. The results of this calculation are presented to the customers for review no later than June 1 each year.

The TU (True-up) tab uses the Actual ATRR from the Actual Net Rev Req tab and compares it to the Projected ATRR (without the True-up for a prior year) that customers were billed for the same period. Interest is added to the difference and the adjusted true-up then is included in the Projected Net Rev Req tab.

The projected O&M and plant balances are calculated in Tabs P-1 thru P-5. These sheets feed into the Projected Gross Rev Req tab and ultimately into the Projected Net Rev Req tab. The RTO Projects Smry tab retrieves project specific data from other tabs to calculate the amount of revenue requirements associated with those projects which are contained in the total Projected Gross Revenue Requirement amount. The Spon Projects Smry tab does the same process for Sponsored projects. The total revenue requirements for these two groups of upgrades and revenue credits are subtracted from the SEPC total revenue requirement to obtain the Zonal ATRR (line 20, before true-up). This calculation is shown on the Projected Net Rev Req tab. This tab also calculates the point-to-point zonal rates. SPP rates are set on the trued up Base Plan Net Revenue Requirements, Balanced Portfolio Net Revenue Requirements, and ITP/Priority Projects Net Revenue Requirements as well as the trued up Zonal Net Revenue Requirements. The specific charges are defined under the SPP Open Access Transmission Tariff.

The FBR is set up initially to address the revenue requirements for six separate special categories: 1) Base Plan, 2) Balanced Portfolio, 3) Integrated Transmission Plan Priority 1, 4) Integrated Transmission Plan Priority 2, 5) Sponsored, and 6) Third Party Projects. From time-to-time it may become necessary to add other categories of special projects.

Cells highlighted in light blue are data input cells. Some cells may reference the results from other calculations in the formula. Such cell references may change from year to year, requiring manual adjustment of the reference or the direct entry of the proper value.

<u>Page</u>	<u>Tab</u>	<u>Description</u>
2	Summary	Summary of projected revenue requirements, point to point rates, and Schedule 1 rates.
3	Actual Net Rev Req	Actual net revenue requirements for most recent calendar year
4-8	Actual Gross Rev Req	Actual gross revenue requirements for most recent calendar year
9	Actual Sch 1 Rev Req	Actual revenue requirements for Schedule 1
10-11	A-1 (Act. Rev. Credits)	Actual revenue credits
12	A-2 (Act. Divisor)	Actual transmission system load
13	A-3 (Act. ADIT)	Actual Accumulated Deferred Income Taxes (ADIT)
14-15	A-4 (Act. Excluded Assets)	Assets excluded from transmission rate base
16	A-5 (Act. Depreciation Rate)	Depreciation rates for each account
17	A-6 (Act. Taxes Other)	Actual taxes other than income taxes
18-25	A-7 (Act. RTO Directed Projects)	Actual RTO-directed projects: Base Plan, Balanced Portfolio, and ITP/Priority Projects
26	A-8 (Act. Sponsored Projects)	Actual sponsor-funded projects
27-34	A-9 (Act. Incentive Plant)	Actual incentive returns
35	A-10 (Act. Third Party Proj)	Actual projects constructed by SEPC for Third Parties
36	A-11 (Act. A&G)	Actual Administrative and General Expenses
37-38	A-12 (Act. 13-Mo & BOY and EOY Aver.)	Actual 13-Month averages and BOY-EOY averages for rate base items
39-40	TU (True-up)	True-up adjustment and interest calculation
41-53	RTO Project Smry	Actual and projected RTO-directed projects
54-55	Spon Project Smry	Actual and projected Sponsor-funded projects
56-57	Third Party Project Smry	Actual and projected Third Party projects
58	Projected Net Rev Req	Projected net revenue requirements for next calendar year
59-63	Projected Gross Rev Req	Projected gross revenue requirements for next calendar year
64	Projected Schedule 1 Rev Req	Projected revenue requirements for Schedule 1
65-70	P-1 (Proj Trans Plant)	Projected transmission plant for next calendar year and incentive returns
71	P-2 (Proj. Exp. & Rev. Credits)	Projected expenses and revenue credits for next calendar year
72	P-3 (Proj. Trans. Network Load)	Projected transmission system load
73-79	P-4 (Proj. RTO Projects)	Projected RTO-directed projects: Base Plan, Balanced Portfolio, ITP/Priority Projects
80	P-5 (Proj. Sponsored. Projects)	Projected sponsor-funded projects
81	P-6 (Proj. Third Party Projects)	Projected projects constructed by SEPC for Third Parties

Sunflower Electric Power Corporation (SEPC)
Rate Formula Template
Projected Revenue Requirements
For the 12 months ended - December 31, 2018

Line No.	(1) <u>Description</u>	(2) <u>Source</u>	(3)	(4) <u>Amount</u>
<u>A. Net Revenue Requirement Including True-Up</u>				
1	Base Plan Net Revenue Requirements	Projected Net Rev Req, L41	\$ 9,315,383	
2	Balanced Portfolio Net Revenue Requirement	Projected Net Rev Req, L42	-	
3	ITP/Priority Projects-1 Net Revenue Requirement	Projected Net Rev Req, L43	-	
4	ITP/Priority Projects-2 Net Revenue Requirement	Projected Net Rev Req, L44	-	
5	Sponsored Projects Net Revenue Requirements	Projected Net Rev Req, L45	-	
6	Third Party Projects Net Revenue Requirements	Projected Net Rev Req, L46	-	
7	Total	Sum (L1:L6)	-	\$ 9,315,383
8				
9	Zonal Net Revenue Requirement	Projected Net Rev Req, L49		\$ 10,164,359
10				
11	<u>B. Point-to-Point Service</u>			
12	SEPC 12-CP. Peak Demand	WP P-3, L15		376.1 MW
13				
14	Annual Point-to-Point Rate in \$/MW - Year	L9 / L12	\$	27,023.000
15	Monthly Point-to-Point Rate in \$/MW - Month	L14 / 12 months	\$	2,252.000
16	Weekly Point-to-Point Rate in \$/MW - Weekly	L14 / 52 weeks	\$	520.000
17	Daily On-Peak Point-to-Point Rate in \$/MW - Day	L14 / 260 days	\$	103.900
18	Daily Off-Peak Point-to-Point Rate in \$/MW - Day	L14 / 365 days	\$	74.000
19	Hourly On-Peak Point-to-Point Rate in \$/MW - Hour	L17 / 16 hours	\$	6.490
20	Hourly Off-Peak Point-to-Point Rate in \$/MW - Hour	L18 / 24 hours	\$	3.080
21				
22	<u>C. Schedule 1 ARR</u>			
23	Net Schedule 1 Revenue Requirement for Zone	Projected Sch 1 Rev Req, L12	\$	988,955
24				
25	<u>D. Schedule 1 Rate Calculations</u>			
26	SEPC 12-CP. Peak Demand	WP P-3, L15		376.1 MW
27				
28	Annual Point-to-Point Rate in \$/MW - Year	L23 / L26	\$	2,629.200
29	Monthly Point-to-Point Rate in \$/MW - Month	L28 / 12	\$	219.100
30	Weekly Point-to-Point Rate in \$/MW - Week	L28 / 52	\$	50.560
31	Daily Point-to-Point Rate in \$/MW - Day	L28 / 365	\$	7.203
32	Hourly Point-to-Point Rate in \$/MW - Hour	L28 / 8760	\$	0.300

Sunflower Electric Power Corporation (SEPC)
Rate Formula Template
Actual Net Revenue Requirements
For the 12 months ended - December 31, 2016

Line No.	(1) <u>Description</u>	(2) <u>Reference</u>	(3)	(4)	(5) <u>Amount</u>
	<u>REVENUE REQUIREMENTS</u> (including approved incentives, if any)				
1	Total Transmission Facilities	Act Gross Rev, Pg. 2, L101, col. 6			\$ 23,602,174
2					
3	Base Plan Gross Revenue Requirements	WP A-7, L23+ L27 + L31, Col. n	\$ 4,043,162		
4	Balanced Portfolio Gross Revenue Requirement	WP A-7, L35, Col. n	-		
5	ITP/Priority Projects-1 Gross Revenue Requirement	WP A-7, L39, Col. n	-		
6	ITP/Priority Projects-2 Gross Revenue Requirement	WP A-7, L43, Col. n	-		
7	Sponsored Gross Revenue Requirements	WP A-8, L4, Col. m	-		
8	Third Party Projects Gross Revenue Requirements	WP-10, L4, Col. m	-		
9	Total	Sum (L3:L8)		\$ 4,043,162	<u>4,043,162</u>
10					
11	Zonal Gross Revenue Requirement	L1 - L9			\$ 19,559,012
12					
13	<u>REVENUE CREDITS</u>				
14					
15	Zonal Gross Revenue Credit	WP A-1, Pg.1 L45			\$ 4,977,015
16					
17	<u>NET REVENUE REQUIREMENT</u>				
18	Base Plan Net Revenue Requirements	L3	\$ 4,043,162		
19	Balanced Portfolio Net Revenue Requirement	L4	-		
20	ITP/Priority Projects-1 Net Revenue Requirement	L5	-		
21	ITP/Priority Projects-2 Net Revenue Requirement	L6	-		
22	Sponsored Project Net Revenue Requirements	L7	-		
23	Third Party Projects Net Revenue Requirements	L8	-		
24	Total	Sum (L18:L23)		\$ 4,043,162	
25					
26	Zonal Net Revenue Requirement	L11 - L15			<u>\$ 14,581,997</u>
27					

Sunflower Electric Power Corporation (SEPC)
Rate Formula Template
Actual Gross Revenue Requirements
For the 12 months ended - December 31, 2016

Line	(1) Description	(2) KCC Annual Report/Workpaper	(3) Total Company	(4)	(5) Allocator	(6) Transmission (Col 3 times Col 5)
1	RATE BASE:					
2	PLANT IN SERVICE (13 month averages)					
3	Production	WP A-12, Pg. 1, L1 & L2	\$ 532,089,083		NA	\$ -
4	Transmission (Excludes Capital Leases)	WP A-12, Pg. 1, L3 Note O	128,044,942		DA 1.00000	128,044,942
5	Less: Excluded Plant	WP A-4, Pg. 1, L13 Note J & K	\$ 3,631,278		DA 1.00000	3,631,278
6	Distribution	WP A-12, Pg. 1, L5	-		NA	-
7	General	WP A-12, Pg. 1, L6	47,383,379		WS 0.26658	12,631,644
8	Intangible & Other	WP A-12, Pg. 1, L7	-		WS 0.26658	-
9	TOTAL GROSS PLANT	Sum (L3:L8) - L5	\$ 707,517,403			\$ 137,045,308
10						
11	ACCUMULATED DEPRECIATION (13 month averages)					
12	Production	WP A-12, Pg. 1, L11 & L12	\$ 363,756,803		NA	\$ -
13	Transmission (Excludes Capital Leases)	WP A-12, Pg. 1, L13, Note O	81,383,687		DA 1.00000	81,383,687
14	Less: Excluded Plant	WP A-4, Pg. 1, L13 Note J & K	\$ 2,227,462		DA 1.00000	2,227,462
15	Distribution	WP A-12, Pg. 1, L15	-		NA	-
16	General	WP A-12, Pg. 1, L16	23,824,313		WS 0.26658	6,351,177
17	Intangible & Other	WP A-12, Pg. 1, L17	-		WS 0.26658	-
18	TOTAL ACCUM. DEPRECIATION	Sum (L12:L17) - L14	\$ 468,964,802			\$ 85,507,402
19						
20	NET PLANT IN SERVICE (13 month averages)					
21	Production	L3- L12	\$ 168,332,280			\$ -
22	Transmission (Excludes Capital Leases)	L4- L13	46,661,255			46,661,255
23	Less: Excluded Plant	L5- L14	\$ 1,403,816			1,403,816
24	Distribution	L6- L15	-			-
25	General	L7- L16	23,559,066			6,280,467
26	Intangible & Other	L8- L17	-			-
27	TOTAL NET PLANT	Sum (L21:L26) - L23	\$ 238,552,601			\$ 51,537,906
28						
29	CONSTRUCTION WORK IN PROGRESS					
30	Production	WP A-12, Pg. 1, L29	\$ 930,397			\$ -
31	Transmission	WP A-12, Pg. 1, L30	1,385,926		DA 1.00000	1,385,926
32	Less: CWIP Assoc. with Third Party and Sponsored Projects					-
33	Distribution	WP A-12, Pg. 1, L31	-			-
34	General Plant	WP A-12, Pg. 1, L32	1,169,909		WS 0.26658	311,879
35	Total	L30 + L31 - L32 + L33 + L34	\$ 3,486,232			\$ 1,697,805
36						
37	ADJUSTMENTS TO RATE BASE					
38	Accumulated Deferred Income Taxes	WP A-3	\$ -		DA 1.00000	\$ -
39	Unrefunded Customer Advances for Construction	Note A	-		DA 1.00000	-
40	Reserve Funds (Non-Escrowed)	WP A-12, Pg. 2, L42	-		DA 1.00000	-
41	Unamortized Abandoned Transmission Plant	WP A-12, Pg. 2, L44, Note S	-		DA 1.00000	-
42	TOTAL ADJUSTMENTS	Sum (L38:L41)	\$ -			\$ -
43						
44	LAND HELD FOR FUTURE USE	WP A-12, Pg. 2, L50 Note B	\$ -		DA 1.00000	\$ -
45						
46	WORKING CAPITAL					
47	CWC					
48	O&M Expense less Fuel	KCC Pg. 36-1, L40d - Pg. 34, L2b -L8b-L35t	\$ 94,184,341		NA	-
49	O&M Expense Allocated to Transmission	Pg. 2, L74, Col (6)	-			\$ 17,142,940
50		Calculated Note C	\$ 11,773,043			\$ 2,142,868
51	Materials & Supplies--Transmission	WP A-12, Pg. 1, L54	1,536,946		TP 0.97799	1,503,123
52	Materials & Supplies--Other	WP A-12, Pg. 1, L52, L53 & L55	12,593,870		NA	-
53	Stores Expense	WP A-12, Pg. 2, L61	-		WS 0.26658	-
54	Prepayments (Account 165)	WP A-12, Pg. 2, L63 (Note D)	1,231,563		GP 0.23373	287,858
55						
56	TOTAL WORKING CAPITAL	Sum (L50:L55)	\$ 27,135,422			\$ 3,933,849
57						
58	Rate Base	Sum(L27, L35, L42, L44, L56)	\$ 269,174,255		RB = 0.21239	\$ 57,169,560

**Sunflower Electric Power Corporation (SEPC)
Rate Formula Template
Actual Gross Revenue Requirements
For the 12 months ended - December 31, 2016**

Line	(1) Description	(2) KCC Annual Report/Workpaper	(3) Total Company	(4)	(5) Allocator	(6) Transmission (Col 3 times Col 5)
59	O&M:					
60	Transmission	KCC Report Pg. 35, L17, Col. b	\$ 42,865,398			
61	Less: Transmission by Others Acct. 565	KCC Report Pg. 35, L6, Col. b (Note E)	28,002,102			
62	Less: Transmission Leases & Facility Charges	SEPC Records	4,618,866			
63	Less Acct. 561 Expense Recovered Through Sch. 1	Actual Sch 1 Rev Req, L10	1,385,295			
64	Total Transmission O&M	L60 - Sum(L61:L63) (Note H)	\$ 8,859,135		TP 0.97799	\$ 8,664,178
65	A&G -Adjusted	WP A-11, L8	\$ 14,387,580		WS 0.26658	3,835,497
66	Plus: Safety Advertising	WP A-11, L9	-		WS 0.26658	-
67	Plus Association Dues Directly Related to Transmission	WP A-11, L10	-		DA 1.00000	-
68	Plus: Advertising -Transmission	WP A-11, L15	-		DA 1.00000	-
69	Plus: Research -Transmission	WP A-11, L20	-		DA 1.00000	-
70	Plus: Regulatory Exp -Transmission	WP A-11, L25	24,400		DA 1.00000	24,400
71	Plus: Corporate Visibility -Transmission	WP A-11, L31	-		WS 0.26658	-
72	Subtotal A&G	L65 + Sum(L66:L71)	\$ 14,411,980			\$ 3,859,896
73	Transmission Lease Payments & Facility Charges	Note F	4,618,866		DA 1.00000	4,618,866
74	TOTAL O&M	L64 + L72 + L73	\$ 27,889,981			\$ 17,142,940
75						
76	DEPRECIATION EXPENSE	Note Q				
77	Production	KCC Report Pg. 38, L2, Col. c	\$ 7,782,979		NA 0.00000	\$ -
78	Transmission	KCC Report Pg. 38, L2, Col. D (Note V)	2,158,029		TP 0.97799	2,110,539
79	Distribution	KCC Report Pg. 38, L2, Col. e	-		NA 0.00000	-
80	General	KCC Report Pg. 38, L2, Col. f	2,365,501		WS 0.26658	630,604
81	Intangible & Other	SEPC Records	-		WS 0.26658	-
82	Amortization of Abandoned Transmission Plant	Acct. 407 (Note S)	-		DA 1.00000	-
83	TOTAL DEPRECIATION	Sum(L77:L82)	\$ 12,306,509			\$ 2,741,143
84						
85	TAXES OTHER THAN INCOME TAXES	(Note I)				
86	LABOR RELATED					
87	Payroll	WP A-6, L9	\$ -		WS 0.26658	\$ -
88	Highway and vehicle	WP A-6, L9	-		WS 0.26658	-
89	PLANT RELATED					
90	Property	WP A-6, L9, (Note M)	-		GP 0.23373	-
91	Gross Receipts	WP A-6, L9	-		NA -	-
92	Other	WP A-6, L9	386		GP 0.23373	90
93						
94	TOTAL OTHER TAXES	Sum(L87:L92)	\$ 386			\$ 90
95						
96	RETURN					
97	Return before incentives	L172	\$ 17,505,643		RB 0.21239	\$ 3,718,000
98	Incentive return	L181	-			-
99	Total Return	L97 + L98	-			\$ 3,718,000
100					0.01381	
101	GROSS REV. REQUIREMENT WITH INCENTIVES	L74 + L83 + L94 + L99				\$ 23,602,174
102	LESS: Gross Revenue Requirements for Incentives	L98				-
103						
104	GROSS REV. REQUIREMENT WITHOUT INCENTIVES	L101 - L102				\$ 23,602,174

**Sunflower Electric Power Corporation (SEPC)
Rate Formula Template
Actual Gross Revenue Requirements
For the 12 months ended - December 31, 2016**

Line	(1) Description	(2) KCC Annual Report/Workpaper	(3) Total Company	(4)	(5) Allocator	(6) Transmission (Col 3 times Col 5)
105	TRANSMISSION PLANT INCLUDED IN FORMULA					
106	Total transmission plant, incl. capital and operating leases	WP-12, L3 + L4 + L10	\$ 165,010,600		DA 1.00000	\$ 165,010,600
107	Less: Substation, 34kV, & Radial Lines to Distr. Plt.	WP A-4, L11 (Note J)	-	-	DA 1.00000	-
108	Less: Total GSU in Transmission Plant	WP A-4, L4 (Note K)	-	3,631,278	DA 1.00000	3,631,278
109	Transmission plant included in rates	L106 - L107 - L 108	\$ 165,010,600			\$ 161,379,322
110	Percentage of transmission plant included in rates	L109 / L106			TP= 0.97799	
111						
112	GROSS AND NET PLANT ALLOCATORS					
113	GROSS PLANT IN SERVICE (ACTUAL HISTORICAL COST)					
114	Production	Pg 1, L3	\$ 532,089,083		NA	\$ -
115	Total transmission plant, including leases (Note T)	WP-12, L3 + L4 + L10	165,010,600		DA 1.00000	165,010,600
116	Less: Excluded Plant	Pg 1, L5	-	3,631,278	DA 1.00000	3,631,278
117	Distribution	Pg 1, L6	-		NA	-
118	General & Intangible	Pg 1, L7 + L8	47,383,379		WS 0.26658	12,631,644
119	TOTAL GROSS PLANT	L114 + L115 - L 116 + L 117 + L118	\$ 744,483,061		GP = 0.23373	\$ 174,010,966
120						
121	ACCUMULATED DEPRECIATION (ACTUAL HISTORICAL COST) (Note Q)					
122	Production	Pg 1, L12	\$ 363,756,803		NA	\$ -
123	Total transmission plant, including leases	WP-12, L13 + L14 + L19	82,381,067		DA 1.00000	82,381,067
124	Less: Excluded Plant	Pg 1, L14	-	2,227,462	DA 1.00000	2,227,462
125	Distribution	Pg 1, L15	-			-
126	General & Intangible	Pg 1, L16 + L17	23,824,313		WS 0.26658	6,351,177
127	TOTAL ACCUM. DEPRECIATION	L122 + L123 - L 124 + L 125 + L126	\$ 469,962,182			\$ 86,504,783
128						
129	NET PLANT IN SERVICE (ACTUAL HISTORICAL COST)					
130	Production	L114 - L122	\$ 168,332,280			\$ -
131	Total transmission plant, including leases	L115 - L123	82,629,533			82,629,533
132	Less Excluded Plant	L116 - L124	-	1,403,816		1,403,816
133	Distribution	L117 - L125	-			-
134	General & Intangible	L118 - L126	23,559,066			6,280,467
135	TOTAL NET PLANT	L130 + L131 - L 132 + L 133 + L134	\$ 274,520,879		NP = 0.31876	\$ 87,506,184
136						
137	WAGES & SALARY ALLOCATOR (WS)					
138	Production	KCC Pg. 37, L1, Col. d	\$ 12,507,277			\$ -
139	Transmission	KCC Pg. 37, L2, Col. d	4,686,804		TP 0.97799	4,583,665
140	Distribution	KCC Pg. 37, L3, Col. d	-			-
141	Other (excluding A&G)	KCC Pg. 37, L4, L5 & L6, Col. d	-			-
142	Total	Sum (L138:L141)	\$ 17,194,081			\$ 4,583,665
143	Wage & Salary Allocator Calculation	Col 6, L142 / Col 3, L142			WS= 0.26658	

Sunflower Electric Power Corporation (SEPC)
Rate Formula Template
Actual Gross Revenue Requirements
For the 12 months ended - December 31, 2016

<u>Line</u>	(1) <u>Description</u>	(2) <u>KCC Annual Report/Workpaper</u>	(3) <u>Total Company</u>	(4)	(5) <u>Allocator</u>	(6) <u>Transmission</u> (Col 3 times Col 5)
144	RETURN (R)	Note N				
145	TIER Test					
146	LT Debt	KCC Pg. 5, L11, Avg. of Col. c & Col. d	\$ 165,509,672			
147	LT Interest Expense (Acct. 427)	KCC Pg. 8, L15, Col. c	7,870,918			
148	ST Interest (Acct. 431)	KCC Pg. 8, L17, Col. c	2,976,148			
149	Total Interest Expense	L147 + L148	\$ 10,847,066			
150	Target TIER	(Note P)	1.7505			
151	Return Requirements (LT Interest plus Margin)	L149 * L150	\$ 18,987,464			
152	Less: Non Operating Income	KCC Pg. 8, L23, Col. C (Note L)	1,660,827			
153	Plus: Amortization of Debt Discount and Debt Expense	KCC Pg. 8, L16, Col. c	179,006			
154	Reserved for Future Use	(Note G)	-			
155						
156	Net Operating Return Req. (accrual basis)	L151 - L152 + L153 + L154 + L155	\$ 17,505,643			
157						
158	DSC Test					
159	Debt Service					
160	LT Interest Expense	L147	\$ 7,870,918			
161	Principal Payment	KCC Pg. 22, L18, Col. E (Note X)	9,365,390			
162	Debt Service	L160 + L161	\$ 17,236,308			
163	Target DSC	(Note P)	1.3585			
164	Return Requirements	L162 * L163	\$ 23,415,627			
165	Less: Non Operating Income	L152	1,660,827			
166	Plus: Amortization of Debt Discount and Debt Expense	L153	179,006			
167	Net Operating Return Req. (cash basis)	L164 - L165 + L166	\$ 21,933,806			
168	Less: Depreciation Expense	L83	12,306,509			
169	Equivalent Return Requirements (accrual basis)	L167 - L168	\$ 9,627,297			
170						
171	Critical Ratio (TIER or DSC)	Greater of L156 or L169	TIER			
172	Return Requirements Greater of TIER or DSC Test	Greater of L156 or L169	\$17,505,643			
173	Average LT Interest Rate	L147 / L146	4.7556%			
174	Average Return on Rate Base	L172 / L58	6.5035%			
175						
176	GROSS REV. REQUIREMENT FOR INCENTIVE PROJECTS					
177	Plant Granted Incentive TIER Adder:					
178	Total Incentive Plant	WP A-9, L27	\$ -			
179	Less: Total Accumulated Depreciation	WP A-9, L27	-			
180	Net Incentive Plant	L178 - L179	\$ -			
181	Incentive Return	WP A-9, L27		\$ -		
182						
183						
184						
185						
186						
187	Abandoned Plant:					
188	Unamortized Abandoned Transmission Plant	L41 of Pg 1 (Note S)	\$ -			
189	Return on Abandoned Plant	L174 * L188	\$ -			
190	Amortization Expense for Abandoned Plant	L82 of Pg. 2	-			
191	Total Recovery for Abandoned Plant	Sum (L189:L190)		\$ -		
192	TOTAL GROSS REV. REQ. FOR INCENTIVE PROJ.	L181 +L185 + L191			\$ -	

**Sunflower Electric Power Corporation (SEPC)
Rate Formula Template
Actual Gross Revenue Requirements
For the 12 months ended - December 31, 2016**

General Note: References to pages in this formula rate are indicated as: (Pg. #, L(in) #, Col.#).
References to data from SEPC's Annual Report to the KCC are indicated as: (Pg. #, L(in) #, Col. #)

Note

- A Reduce Rate Base by Unrefunded Transmission customer advances for construction. This line shall be directly assigned 100% to Transmission. Provide separate workpaper to support adjustment.
- B Includes only Land Held for Future Use associated with Transmission facilities.
- C Cash Working Capital assigned to transmission is one-eighth of O&M allocated to transmission at Pg. 2, L74, Col. 6.
- D Prepayments are the electric related prepayments booked to Acct. 165 and reported on SEPC's KCC Annual Report Pg. 17, L20, Col. b.
- E Expenses recorded in Account 565, Transmission of Electricity by Others, are not recoverable through the formula rate.
- F Lease and joint facilities charges included on L62, page 2 of 5, are those costs attributable to transmission service.
- G This line shall not be populated unless authorized by the Commission.
- H Transmission O&M on this line does not include any SPP charges for Schedule 1-A of the SPP OATT.
- I Includes only unallocated FICA, unemployment, highway, property, gross receipts, and other assessments charged in the current year. Pursuant to RUS accounting standards, the majority of this other tax expense is allocated directly to the appropriate O&M accounts. Taxes related to income are excluded. Gross receipts taxes are not included in transmission revenue requirement in the Rate Formula Template.
- J Removes transmission plant determined by Commission order to be excluded from RTO transmission rate base to the extent that plant balances are not adjusted.
- K Removes generator step-up facilities determined by Commission order to be excluded from RTO transmission rate base to the extent plant balances are not adjusted. SEPC records this investment in a transmission plant account.
- L As more fully described in Section C.3.e. of the Protocols, any amounts received from ITC Great Plains, LLC (ITC), shall be booked as non-operating income in the year received.
- M If the transmission related component of property tax is specifically identified in SEPC's KCC Annual Report, then a TP allocator shall be used. Property tax shall be allocated to transmission by the GP allocator if transmission related property tax is not specifically identified in the KCC Annual Report.
- N Return is based on the maximum of either a TIER or DSC test.
- O Does not include leases since return associated with leased facilities is included in the lease payment.
- P The approved TIER and DSC ratios will be established by the KCC. No change in TIER and DSC may be made absent a filing with the KCC. Any incentive ROEs approved by the FERC are shown by project in Worksheet A-9.
- Q The current depreciation rates used to calculate depreciation expense and accumulated depreciation balances are shown in worksheet A-5 (Act. Depreciation Rate).
- R Reserved for future use.
- S The Unamortized Abandoned Transmission Plant can only be included in rate base if authorized by the Commission.
- T The GP allocator is primarily used to allocate prepaid insurance payments; and Sunflower provide property insurance for leased facilities.
- U Reserved for future use.
- V Includes depreciation of capital lease improvements.
- W Reserved for future use.
- X Excludes Residual Value Note (RVN) balloon principal payment

ALLOCATION FACTORS

<u>Line</u>	<u>Allocators</u>	<u>Description</u>	<u>Source</u>	<u>Amount</u>
1	RB	Percentage of rate base attributable to transmission	Pg. 2, L58, Col.5	0.21239
2	TP	Percentage of transmission plant included in rate base.	Pg. 3, L110, Col.5	0.97799
3	WS	Percentage of transmission labor included in rates	Pg. 3, L143, Col.6	0.26658
4	DA	Direct assignment		1.00000
5	GP	Ratio of allocated transmission, general, & intangible plant to total gross plant.	Pg. 3, L119, Col.5	0.23373
6	NA	Not applicable for the transmission formula rate.		-
7	NP	Ratio of net transmission, general, & intangible plant to total net plant.	Pg. 3, L135, Col.5	0.31876

Sunflower Electric Power Corporation (SEPC)
Rate Formula Template
Utilizing FERC KCC Annual Report Data
Actual Schedule 1 Revenue Requirements
For the 12 months ended - December 31, 2016

<u>Line No.</u>	(1) <u>Description</u>	(2) <u>Reference</u>	(3) <u>Amount</u>
A. Schedule 1 ARR			
1	Total Scheduling, System Control and Dispatch Service	KCC Annual Report, Pg. 35, L2, col. B	\$ 1,385,295
2	Plus: Acct. 556 SPP NERC Compliance Charges	NERC Quarterly Assessments (50% of total)	-
3	Less: Scheduling, System Control and Dispatch Services		-
4	Less: Transmission Service Studies		-
5	Less: Reliability, Planning & Standards Dev. Services		-
6	Total	L1 + L2 - L3 - L4 - L5	\$ 1,385,295
7	Plus: NERC Penalties Associated with Transmission	Acct. 42630 (Note A)	\$ -
8	Less: PTP Service Credit	WP A-1, Pg. 1, L26	176,984
9	Net Schedule 1 Revenue Requirement for Zone	L6 + L7 - L8	<u>\$ 1,208,311</u>
10	Acct. 561 Expenses Recovered Through Sch. 1 Charges	L1 - Sum(L3:L5)	\$ 1,385,295
B. Schedule 1 Rate Calculations			
11	SEPC 12-CP. Peak Demand	WP A-2, L14	385.2 MW
12	Annual Point-to-Point Rate in \$/MW - Year	L9 / L11	\$ 3,136.50
13	Monthly Point-to-Point Rate in \$/MW - Month	L12 / 12	\$ 261.40
14	Weekly Point-to-Point Rate in \$/MW - Week	L12 / 52	\$ 60.32
15	Daily Point-to-Point Rate in \$/MW - Day	L12 / 365	\$ 8.59
16	Hourly Point-to-Point Rate in \$/MW - Hour	L12 / 8760	\$ 0.36

A Includes only NERC Penalties where payment is made subsequent to January 1, 2013. If any interested party files a Formal Objection to such collection, as more fully described in Section C.3.e.(B) of the Protocols, recovery with interest from the date the amount was paid, shall be included in the next Annual Tru-Up after final determination by the Commission.

**Sunflower Electric Power Corporation (SEPC)
Revenue Credits
For the 12 Months Ended December 31, 2016**

<u>Line</u>	<u>Description</u>	<u>Total Company</u>	<u>Non- Transmission</u>	<u>Transmission</u>
1	<u>I. Rent from Electric Property, Account 454 (Note 12)</u>			
2	Account 4540001 - Other Rev -Rent Electric Property	\$ -	\$ -	\$ -
3	Transmission:			
4	Farm Land Rental	-		
5	Rental From Cell Phone Attaches	-		
6	Equipment / Facilities Rental	\$ -		
7	Rental Substation Property -Cell Towers	-		
8	Other Rental	-		
9	Total Transmission	\$ -		
10	(Revenue related to transmission facilities for pole attachments, rentals, etc. Provide data sources and explanations in Section V, Notes below.)			
11				
12	<u>II. Other Operating Revenues To Reduce Revenue Requirement</u>			\$ -
13				
14	<u>III. Other Electric Revenue, Account 456</u>			\$ 61,387,225
15	(Provide data sources and necessary explanations in Notes below.)			
16	Less:			
17	TO's LSE Direct Assignment Revenue Credits (Explanation required if populated)			
18	TO's LSE Sponsored Upgrade Revenue Credits (Explanation required if populated)			
19	TO's LSE Sch. 11 Rev. from Sponsored or Direct Assign Facilities - Network Credits (Explanation required if populated)			
20	TO's LSE Sch. 11 Rev. from Sponsored or Direct Assign Facilities - PtP Credits (Explanation required if populated)			
21	TO's LSE Network Upgrades for Generation Interconnection - Credits (Explanation required if populated)			
22	Point-To-Point Revenue for GFAs Associated with Load Included in the Divisor (Explanation required if poulated)			
23	Network Service Revenue (Schedule 9) Associated With Load Included in the Divisor (Note 3)		34,264,780	
24	Revenue Associated with Transmission Plant Excluded From SPP Tariff			
25	Wholesale Distribution Revenue (WDR) (Note 2)			
26	Schedule 1 Revenue	176,984		4,714,480
27	Schedule 2 Revenue			
28	Schedules 3-6 Revenue			-
29	Revenue for TO's Facilities Under Schedule 11			
30	Zonal Network Revenue for TO's Facilities Under Schedule 11 - (Note 3)		4,445,393	
31	Region-wide Network Revenue for TO's Facilities Under Schedule 11 - (Note 3)		2,090,325	
32	Zonal Point-to-Point Revenue for TO's Facilities Under Schedule 11 - (Note 3)		292,745	
33	Region-wide Point-to-Point Revenue for TO's Facilities Under Schedule 11 - (Note 3)		387,837	
34	Subtotal	\$ 7,216,301		
35	Less: Rev. From Sch. 11 Projects Not In Service as of 12/31/2016 or Excess Sch. 11 Rev. (Note 9).		1,088,190	
36	Net Schedule 11 Revenue Associated With Special Projects in Service during 2010 (See L55)			6,128,111
37	Other - Revenue from bundled transmission service to Members. (Note 4)			147,828
38	Other -			
39	Other -			-
40	Other - Revenue to cover use of administrative assets by other entities.(Note 7)	757,119	0.26658	555,284
41	Other - Revenue associated with covering losses. (Note 8)			12
42	Other - Revenue from TDC type charges to members			10,599,714
43	Total Adjustments			56,410,209
44	Net 456 Account Transmission Related Activity			\$ 4,977,015
45	<u>IV. Total Revenue Credits to Apply to Zonal Revenue Requirement</u>			\$ 4,977,015

Sunflower Electric Power Corporation (SEPC)
Revenue Credits
For the 12 Months Ended December 31, 2016

<u>Line</u>	<u>Description</u>	<u>Source</u>	<u>Amount</u>
46	Total Sch. 11 Revenue Received in 2016	L34	\$ 7,216,301
47			
48	Net Projected ATRR for Projects Completed as of 12/31/2016 for which Revenue was Received in 2016	Notes 10, 11	
49	Johnson to Pioneer 115kV Line		1,169,229
50	Johnson Corner Capacitor Bank =1		140,289
51	Johnson Corner Capacitor Bank =2		101,863
52	Holcomb to Fletcher 115kV (Wheatland Lessor)		1,501,234
53	Holcomb to Plymell 115kV (MKEC Lessor)		1,131,994
54	Plymell to Pioneer Tap 115kV (MKEC Lessor)		1,438,639
55	Mingo 345/115 kV Ckt 2 Transformer		453,504
56	Mingo 345 kV Terminal Upgrades		191,358
57	Total Projected ATRR for Projects Completed as of 12/31/2016	Sum(L49:L54) (Total goes in L36)	\$ 6,128,111
58			
59	Net Schedule 11 Revenue to be Applied as a Credit to Zonal ATRR in 2016	L46 - L55 (Total goes in L35)	\$ 1,088,190
60	Other Revenue Credits Applied to Zonal Revenue Requirements		3,888,825
61	Total Revenue Credits Applied to Zonal revenue requirements		\$ 4,977,015

Notes:

- (1) Data for this worksheet came from SEPC's Annual Report to the KCC and the Company's General Ledger.
- (2) SEPC collected revenue for a Local Access Charge (LAC) through January, 2010 when the responsibility was transferred to the Member-Systems and its current OATT went into effect.
- (3) Includes any revenue from direct assignment to a customer of costs of a Base Plan, Balanced Portfolio, Priority or ITP project.
- (4) Bundled transmission service for Sch. 1, 2, 3, 5 & 6, WDR and loss billed to the SEPC Members. See Note 2 as well.
- (5) Reserved for future use.
- (6) Reserved for future use.
- (7) Revenue from other entities to cover use of administrative assets. The non-transmission portion is equal to Actual Revenue * (1-WS Allocator).
- (8) Revenue associated with supplying energy losses.
- (9) Schedule 11 revenue for projects not yet completed as of 12/31/2016 and excess revenue (i.e., revenue less ATRR) for Sch. 11 projects completed by 12/31/2016 is assigned as a revenue credit against zonal ATRR. See page 2, L57
- (10) The Net Revenue Requirement with True-up from Projection for Actual Period, Schedule "Projected Net Rev Req," taken from the FBR two years prior to the current one (i.e., when the ATRR for these projects was established).
- (11) None of the Schedule 11 revenue received in 2016 was associated with projects completed as of 12/31/2016
- (12) Excludes lease revenue on assets expected to be recorded as long-term leases.

**Sunflower Electric Power Corporation (SEPC)
Determination of Transmission Network Load (MW)
For the 12 months ended December 31, 2016**

<u>Line</u>	<u>Date</u>	<u>Hour Ending</u>	<u>SEPC's Native System Peak Load</u>	<u>Adjustment</u>	<u>Adjusted SEPC's Native System Peak Load</u>	<u>Plus: 3rd Party Network Load (incl. gen.)</u>	<u>Reserve for Future Use</u>	<u>Plus: Grandfather Agreements</u>	<u>Reserve for Future Use</u>	<u>Reserve for Future Use</u>	<u>Less: Load Not Connected to the SEPC Transmission System</u>	<u>SEPC's Transmission System Load (e-f+g+h+i+j-k)</u>	<u>Average Transmission Network Load for January thru August</u>	<u>Percentage of Aver. Jan -Aug Load</u>
	(a)	(b)	(c)	(d)	(e)	(f)	(g)	(h)	(i)	(j)	(k)	(l)	(m)	(n)
1	1/8/2016	12:00	264.5	-	264.5	58.2	-	-			-	322.7	322.7	
2	2/5/2016	10:00	260.0	-	260.0	52.9	-	-			-	312.8	312.8	
3	3/31/2016	11:00	279.2	-	279.2	47.7	-	-			-	326.9	326.9	
4	4/8/2016	11:00	292.5	-	292.5	42.7	-	-			-	335.2	335.2	
5	5/25/2016	16:00	294.0	-	294.0	69.1	-	-			-	363.1	363.1	
6	6/21/2016	16:00	404.4	-	404.4	98.9	-	-			-	503.3	503.3	
7	7/21/2016	16:00	426.2	-	426.2	103.4	-	-			-	529.6	529.6	
8	8/1/2016	17:00	416.1	-	416.1	101.4	-	-			-	517.5	517.5	
9	9/6/2016	16:00	327.9	-	327.9	86.5	-	-			-	414.4		103.24%
10	10/3/2016	16:00	282.8	-	282.8	69.0	-	-			-	351.7		87.62%
11	11/3/2016	7:00	263.6	-	263.6	48.4	-	-			-	312.0		77.72%
12	12/17/2016	12:00	276.1	-	276.1	57.7	-	-			-	333.8		83.16%
13	Total		3,787.1	n/a	3,787.1	835.90	-	-	-	-	-	4,623.0	401.4	
14	12-CP		315.6	n/a	315.6	69.7	-	-	-	-	-	385.2		

Notes:

Column (n) :This column reflects the relationship of the actual load for each month (September, October, November and December) as a percentage of the average transmission network load for January through August. For example, the September percentage in column (n) is equal to the September load in column (l) divided by the 8-month average of column (m) shown on line 13.

Sunflower Electric Power Corporation (SEPC)
Allocation of ADIT
For the 12 months ended December 31, 2016

SEPC is a taxable cooperative subject to income taxes to the extent that income or losses are allocated to nonpatron activity. The ADIT as of 12/31/16 is \$0. See Note 6 of the notes to combined financial statements found in the 2014 Audit Report for additional information on the calculation of ADIT.

Sunflower Electric Power Corporation (SEPC)
Excluded Assets--Assets Transferred from Transmission Rate Base
As of December 31, 2016

<u>Line</u>	<u>13 -Month Average Balance</u>			
	<u>Plant in</u>	<u>Depr.</u>		
	<u>Service</u>	<u>Reserve</u>	<u>Net</u>	
1				
2				
3	<u>I. GSU Values Transferred from Transmission</u>			
4	Total GSUs in Transmission Plant	\$ 3,631,278	\$ 2,227,462	\$ 1,403,816
5				
6	<u>II. Radial Lines, 34kV and Substation Facilities Transferred</u>			
7	Radial Lines	\$ -	\$ -	\$ -
8	Substation Facilities Transf to Distribution Plt.	-	-	-
9	34 kV Lines	-	-	-
10	Less: Substation Facilities Transf to Trans. Plant	-	-	-
11	Net Substation, 34kV, & Radial Lines to Dist. Plt	\$ -	\$ -	\$ -
12				
13	<u>III. Net Transfer From Trans. (L4 + L11)</u>	\$ 3,631,278	\$ 2,227,462	\$ 1,403,816

Sunflower Electric Power Corporation (SEPC)
Excluded Assets--Assets Transferred from Transmission Rate Base
As of December 31, 2016

IV. 13 Month Average -Gross Plant

Line	Gross Plant													13 Months Avg Balance	
	2015 Dec	2016 Jan	2016 Feb	2016 Mar	2016 Apr	2016 May	2016 Jun	2016 Jul	2016 Aug	2016 Sep	2016 Oct	2016 Nov	2016 Dec		
14	GSU	\$ 3,631,278	\$ 3,631,278	\$ 3,631,278	\$ 3,631,278	\$ 3,631,278	\$ 3,631,278	\$ 3,631,278	\$ 3,631,278	\$ 3,631,278	\$ 3,631,278	\$ 3,631,278	\$ 3,631,278	\$ 3,631,278	\$ 3,631,278
15	Radial Lines	-	-	-	-	-	-	-	-	-	-	-	-	-	\$ -
16	Substation -Transferred to Dist. Plant	-	-	-	-	-	-	-	-	-	-	-	-	-	\$ -
17	34 kV Lines	-	-	-	-	-	-	-	-	-	-	-	-	-	\$ -
18	Less: Substa. Facil. Tranf to Transm. Plant	-	-	-	-	-	-	-	-	-	-	-	-	-	\$ -
19	Total -Excluded Assets	\$ 3,631,278	\$ 3,631,278	\$ 3,631,278	\$ 3,631,278	\$ 3,631,278	\$ 3,631,278	\$ 3,631,278	\$ 3,631,278	\$ 3,631,278	\$ 3,631,278	\$ 3,631,278	\$ 3,631,278	\$ 3,631,278	\$ 3,631,278

V. 13 Month Average -Accumulated Depreciation

	Accumulated Depreciation													13 Months Avg Balance	
	2015 Dec	2016 Jan	2016 Feb	2016 Mar	2016 Apr	2016 May	2016 Jun	2016 Jul	2016 Aug	2016 Sep	2016 Oct	2016 Nov	2016 Dec		
20	GSU	\$ 2,194,420	\$ 2,199,927	\$ 2,205,434	\$ 2,210,941	\$ 2,216,448	\$ 2,221,955	\$ 2,227,462	\$ 2,232,969	\$ 2,238,476	\$ 2,243,983	\$ 2,249,490	\$ 2,254,997	\$ 2,260,504	\$ 2,227,462
21	Radial Lines	-	-	-	-	-	-	-	-	-	-	-	-	-	\$ -
22	Substation -Transferred to Dist. Plant	-	-	-	-	-	-	-	-	-	-	-	-	-	\$ -
23	34 kV Lines	-	-	-	-	-	-	-	-	-	-	-	-	-	\$ -
24	Less: Substa. Facil. Tranf to Transm. Plant	-	-	-	-	-	-	-	-	-	-	-	-	-	\$ -
25	Total -Excluded Assets	\$ 2,194,420	\$ 2,199,927	\$ 2,205,434	\$ 2,210,941	\$ 2,216,448	\$ 2,221,955	\$ 2,227,462	\$ 2,232,969	\$ 2,238,476	\$ 2,243,983	\$ 2,249,490	\$ 2,254,997	\$ 2,260,504	\$ 2,227,462

VI. 13 Month Average -Net Plant

	Net Plant (Gross Plant less Accumulated Depreciation)													13 Months Avg Balance	
	2015 Dec	2016 Jan	2016 Feb	2016 Mar	2016 Apr	2016 May	2016 Jun	2016 Jul	2016 Aug	2016 Sep	2016 Oct	2016 Nov	2016 Dec		
26	GSU	1,436,858	1,431,351	1,425,844	1,420,337	1,414,830	1,409,323	1,403,816	1,398,309	1,392,802	1,387,295	1,381,788	1,376,281	1,370,774	\$ 1,403,816
27	Radial Lines	-	-	-	-	-	-	-	-	-	-	-	-	-	\$ -
28	Substation -Transferred to Dist. Plant	-	-	-	-	-	-	-	-	-	-	-	-	-	\$ -
29	34 kV Lines	-	-	-	-	-	-	-	-	-	-	-	-	-	\$ -
30	Less: Substa. Facil. Tranf to Transm. Plant	-	-	-	-	-	-	-	-	-	-	-	-	-	\$ -
31	Total -Excluded Assets	\$ 1,436,858	\$ 1,431,351	\$ 1,425,844	\$ 1,420,337	\$ 1,414,830	\$ 1,409,323	\$ 1,403,816	\$ 1,398,309	\$ 1,392,802	\$ 1,387,295	\$ 1,381,788	\$ 1,376,281	\$ 1,370,774	\$ 1,403,816

Sunflower Electric Power Corporation (SEPC)
Worksheet A-5 - Depreciation Rates
As of December 31, 2016

<u>Line</u>	<u>A/C</u>	<u>Description</u>	<u>Rate</u>
1	301	Organization	N.A.
2	302	Franchises	N.A.
3	303	Misc Intangible Plant	N.A.
4	350	Land & Land Rights	0.00%
5	352	Structures and Improvements	2.17%
6	353	Station Equipment	1.82%
7	354	Towers and Fixtures	1.59%
8	355	Poles and Fixtures	1.80%
9	356	Overhead Conductors and Devices	1.69%
10	357	Underground Conduit	N.A.
11	358	Underground Conductors and Devices	N.A.
12	389	Land and Land Rights	0.00%
13	390	Structures and Improvements	1.23%
14	391	Office Furniture and Equipment	8.39%
15	39106	Gen Plt-SJ OffMachines1987	N.A.
16	39102	Gen Plt-Computer Hardware	N.A.
17	39104	Gen Plt-Software	N.A.
18	392	Transportation Equipment	5.93%
19	393	Stores Equipment	0.00%
20	394	Tools, Shop and Garage Equipment	3.03%
21	395	Laboratory Equipment	2.81%
22	396	Power Operated Equipment	1.33%
23	397	Communication Equipment	3.26%
24	398	Miscellaneous Equipment	4.40%
25	399	Other Tangible Property	N.A.
26			
27		Weighted Average Transmission Depreciation Rate	
28		Transmission Depreciation Expense in 2016	Actual Gross Rev Req L78, Col (3) \$ 2,158,029
29		Transm. Plant in Service (12 mo. avg. Dec., 2015 to Nov., 2016)	WP A-12, L9 \$ 127,983,967
30		Average Annual Transmission Depreciation Rate	L28 / L29 1.6862%
31		Average Monthly Transmission Depreciation Rate	L30 / 12 0.1405%

Notes

**Sunflower Electric Power Corporation (SEPC)
Taxes Other Than Income Taxes
For the 12 Months Ended December 31, 2016**

Source: KCC Annual Report, Pg. 42

<u>Line No.</u>	<u>Description</u>	<u>Electric Acct</u>		<u>Adjusted</u>	<u>Payroll</u>	<u>Highway & Vehicle</u>	<u>Property</u>	<u>Gross Receipts, Uses & KC Earning Tax</u>		<u>Other</u>	<u>Other Misc</u>	<u>Total of Cost Distribution</u>
		<u>408.1, 409.1</u>	<u>Excluded</u>					<u>Tax</u>	<u>Other</u>			
1	Ad Valorem	-	-	-								-
2	Excise	-	-	-		-						-
3	Franchise -Corporate	-	-	-				-				-
4	Payroll (Note A)	-	-	-	-							-
5	Transaction	-	-	-				-				-
6	Property Taxes (Note A)	-	-	-				-				-
7	KC Earnings	-	-	-				-				-
8	Miscellaneous	386	-	386						386		386
9		386	-	386	-	-	-	-	-	386	-	386
10												
11	Income Taxes (Note B)											
12	Federal	6,878										
13	State	1,280										
14												
15		<u>8,544</u>										

Notes

- A In accordance with RUS accounting guidelines, most of these taxes are distributed directly to the various O&M and construction accounts.
- B Income taxes are associated with Sunflower Electric Holdings (Old Sunflower).

**Sunflower Electric Power Corporation (SEPC)
Actual RTO Directed Transmission Projects
For the 12 months ended - December 31, 2016**

<u>Line</u>	<u>Description</u>	<u>Source</u>	<u>Total System</u>	
1	Transm. Gross Plant, incl. Leases, excl. Excluded Plant	Actual Gross Rev Req L109, Col 6	\$ 161,379,322	
2	Transmission Net Plant in Service (Excludes Leases)	Actual Gross Rev Req L22, Col. 6	\$ 46,661,255	
3	Plus: Net Plant Attributable to Capital Lease Projects	A-12, Pg. 1, L23	19,312,562	Investment associated with <u>capital</u> leases is recorded on Sunflower's books.
4	Plus: Net Plant Attributable to Operating Lease Projects	A-12, Pg. 1, L28	16,655,715	Investment associated with <u>operating</u> leases is <u>not</u> recorded on Sunflower's books.
5	Less: Net Plant Excl. for O&M, Other Taxes and General Plant	Note A	-	
6	Adjusted Net Plant for O&M and Other Taxes	L2 + L3 + L4 - L5	\$ 82,629,533	
7	Transmission O&M (includes allocation of A&G)	Actual Gross Rev Req L74 - L73	\$ 12,524,074	Excludes lease payments and Facilities charges
8	Percent of Net Plant	L7 / L6	15.16%	
9	Other Taxes	Actual Gross Rev Req L94	\$ 90	
10	Percent of Net Plant	L9 / L6	0.00%	
11	General & Intangible Plant Allocation			
12	Depreciation	Actual Gross Rev Req L80 + L81	\$ 630,604	
13	Return	Actual Gross Rev Req ((L25+L26) / L27)*L97	453,080	
14	Total	L12 + L13	\$ 1,083,684	
15	Percent of Net Plant	L14 / L6	1.31%	
16	Return (New Facilities)		8.32%	
		Actual Gross Rev Req L173 * L150		

Note A: For some Special Projects, constructed on behalf of others, SEPC may contract with the other party to provide O&M for the subject facilities. In such instances, the O&M is not recorded on SEPC's books. No such projects existed in 2016.

I. Summary of Actual RTO Directed Transmission Projects

(a)	(b)	(c)	(d)	(e)	(f)	(g)	(h)	(i)	(j)	(k)	(l)	(m)	(n)
<u>Project No.</u>	<u>Project ID</u>	<u>Description</u>	<u>In Service Date</u>	<u>Gross Plant</u> (see below)	<u>Net Plant</u> (see below)	<u>O&M and A&G Allocated Expense</u> (f * L8)	<u>Other Taxes</u> (f * L10)	<u>General Plant Allocation</u> (f * L15)	<u>Depreciation Expense</u> (see below)		<u>Non Incentive Return</u> (f * L16)	<u>Incentive Return</u> (WP A-9)	<u>Gross Revenue Requirements</u> (g+h+i+j+k+l+m)
A. Base Plan Projects (Sunflower Owned)													
17	1	256	Johnson to Pioneer 115kV Line	AUG-10	\$ 3,117,703	\$ 2,812,778	\$ 426,330	\$ 3	\$ 36,890	\$ 52,570	\$ 234,149	\$ -	\$ 749,941
18	2	30234	Johnson Corner Capacitor Bank #1	MAY-12	\$ 363,269	\$ 338,109	\$ 51,247	\$ 0	\$ 4,434	\$ 6,125	\$ 28,146	\$ -	\$ 89,953
19	3	30235	Johnson Corner Capacitor Bank #2	MAY-12	\$ 263,647	\$ 245,503	\$ 37,211	\$ 0	\$ 3,220	\$ 4,446	\$ 20,437	\$ -	\$ 65,313
20	4	0	0		\$ -	\$ -	\$ -	\$ -	\$ -	\$ -	\$ -	\$ -	\$ -
21	5	0	0		\$ -	\$ -	\$ -	\$ -	\$ -	\$ -	\$ -	\$ -	\$ -
22	6	0	0		\$ -	\$ -	\$ -	\$ -	\$ -	\$ -	\$ -	\$ -	\$ -
23	Total Base Plan Projects (Sunflower Owned)				\$ 3,744,619	\$ 3,396,390	\$ 514,787	\$ 4	\$ 44,544	\$ 63,141	\$ 282,732	\$ -	\$ 905,207
B. Base Plan Projects (Capital Lease)													
24	1	899	Holcomb to Fletcher 115kV Line (Wheat)	NOV-13	\$ 4,091,866	\$ 3,255,611	\$ 493,450	\$ 4	\$ 42,697	\$ 586,636			\$ 1,122,786
25	2	0	0		\$ -	\$ -	\$ -	\$ -	\$ -	\$ -			\$ -
26	3	0	0		\$ -	\$ -	\$ -	\$ -	\$ -	\$ -			\$ -
27	Total Base Plan Projects (Capital Leases)				\$ 4,091,866	\$ 3,255,611	\$ 493,450	\$ 4	\$ 42,697	\$ 586,636			\$ 1,122,786
C. Base Plan Projects (Operating Lease)													
28	1	166	Holcomb to Plymell	JUN-12	\$ 3,400,999	\$ 3,228,573	\$ 489,352	\$ 4	\$ 42,343	\$ 355,700			\$ 887,398
29	2	367	Plymell to Pioneer	JUN-12	\$ 4,322,255	\$ 4,103,126	\$ 621,907	\$ 4	\$ 53,812	\$ 452,047			\$ 1,127,771
30	3	0	0		\$ -	\$ -	\$ -	\$ -	\$ -	\$ -			\$ -
31	Total Base Plan Projects (Operating Leases)				\$ 7,723,254	\$ 7,331,699	\$ 1,111,258	\$ 8	\$ 96,155	\$ 807,747			\$ 2,015,168
D. Balanced Portfolio Projects													
32	1	0	0		\$ -	\$ -	\$ -	\$ -	\$ -	\$ -	\$ -	\$ -	\$ -
33	2	0	0		\$ -	\$ -	\$ -	\$ -	\$ -	\$ -	\$ -	\$ -	\$ -
34	3	0	0		\$ -	\$ -	\$ -	\$ -	\$ -	\$ -	\$ -	\$ -	\$ -
35	Total Balanced Portfolio Projects				\$ -	\$ -	\$ -	\$ -	\$ -	\$ -	\$ -	\$ -	\$ -
E. ITP Priority 1 Projects													
36	1	0	0		\$ -	\$ -	\$ -	\$ -	\$ -	\$ -	\$ -	\$ -	\$ -
37	2	0	0		\$ -	\$ -	\$ -	\$ -	\$ -	\$ -	\$ -	\$ -	\$ -
38	3	0	0		\$ -	\$ -	\$ -	\$ -	\$ -	\$ -	\$ -	\$ -	\$ -
39	Total ITP Priority 1 Projects				\$ -	\$ -	\$ -	\$ -	\$ -	\$ -	\$ -	\$ -	\$ -
F. ITP Priority 2 Projects													
40	1	0	0		\$ -	\$ -	\$ -	\$ -	\$ -	\$ -	\$ -	\$ -	\$ -
41	2	0	0		\$ -	\$ -	\$ -	\$ -	\$ -	\$ -	\$ -	\$ -	\$ -
42	3	0	0		\$ -	\$ -	\$ -	\$ -	\$ -	\$ -	\$ -	\$ -	\$ -
43	Total ITP Priority 2 Projects				\$ -	\$ -	\$ -	\$ -	\$ -	\$ -	\$ -	\$ -	\$ -

**Sunflower Electric Power Corporation (SEPC)
Actual RTO Directed Transmission Projects
For the 12 months ended - December 31, 2016**

II. Calculation of Net Plant for Sunflower Owned Base Plan Funded Projects:

		Johnson to Pioneer 115kV Line			Johnson Corner Capacitor Bank #1			Johnson Corner Capacitor Bank #2			
		Project: 1			Project: 2			Project: 3			
		SPP Proj. ID 256			SPP Proj. ID 30234			SPP Proj. ID 30235			
Year	Month	Plant Balance by Month	Depr. Rate / 12 (notes B & C)	Depreciation Expense	Plant Balance by Month	Depr. Rate / 12 (notes B & C)	Depreciation Expense	Plant Balance by Month	Depr. Rate / 12 (notes B & C)	Depreciation Expense	
44	2015	Dec	\$ 3,117,703		\$ 363,269		\$ 510	\$ 263,647		\$ 370	
45	2016	Jan	\$ 3,117,703	0.1405%	\$ 4,381	\$ 363,269	0.1405%	\$ 510	\$ 263,647	0.1405%	\$ 370
46	2016	Feb	\$ 3,117,703	0.1405%	\$ 4,381	\$ 363,269	0.1405%	\$ 510	\$ 263,647	0.1405%	\$ 370
47	2016	Mar	\$ 3,117,703	0.1405%	\$ 4,381	\$ 363,269	0.1405%	\$ 510	\$ 263,647	0.1405%	\$ 370
48	2016	Apr	\$ 3,117,703	0.1405%	\$ 4,381	\$ 363,269	0.1405%	\$ 510	\$ 263,647	0.1405%	\$ 370
49	2016	May	\$ 3,117,703	0.1405%	\$ 4,381	\$ 363,269	0.1405%	\$ 510	\$ 263,647	0.1405%	\$ 370
50	2016	Jun	\$ 3,117,703	0.1405%	\$ 4,381	\$ 363,269	0.1405%	\$ 510	\$ 263,647	0.1405%	\$ 370
51	2016	Jul	\$ 3,117,703	0.1405%	\$ 4,381	\$ 363,269	0.1405%	\$ 510	\$ 263,647	0.1405%	\$ 370
52	2016	Aug	\$ 3,117,703	0.1405%	\$ 4,381	\$ 363,269	0.1405%	\$ 510	\$ 263,647	0.1405%	\$ 370
53	2016	Sep	\$ 3,117,703	0.1405%	\$ 4,381	\$ 363,269	0.1405%	\$ 510	\$ 263,647	0.1405%	\$ 370
54	2016	Oct	\$ 3,117,703	0.1405%	\$ 4,381	\$ 363,269	0.1405%	\$ 510	\$ 263,647	0.1405%	\$ 370
55	2016	Nov	\$ 3,117,703	0.1405%	\$ 4,381	\$ 363,269	0.1405%	\$ 510	\$ 263,647	0.1405%	\$ 370
56	2016	Dec	\$ 3,117,703	0.1405%	\$ 4,381	\$ 363,269	0.1405%	\$ 510	\$ 263,647	0.1405%	\$ 370
57				Sum lines 45 - 56	\$ 52,570		Sum lines 45 - 56	\$ 6,125		Sum lines 45 - 56	\$ 4,446
58				2015 EOY Accum. Depr:	278,640		2015 EOY Accum. Depr:	22,097		2015 EOY Accum. Depr:	15,921
Year	Total			Year	Total			Year	Total		
Year	Gross Plant	Accm. Deprac.	Net Plant	Year	Gross Plant	Accm. Deprac.	Net Plant	Year	Gross Plant	Accm. Deprac.	Net Plant
60	13 Month Averages			60	13 Month Averages			60	13 Month Averages		
61	2010	\$ 1,199,117	\$ 2,892	\$ 1,196,225	2010	\$ 1,199,117	\$ 2,892	\$ 1,196,225	\$ -	\$ -	\$ -
62	2011	\$ 3,117,703	\$ 41,868	\$ 3,075,835	2011	\$ 3,117,703	\$ 41,868	\$ 3,075,835	\$ -	\$ -	\$ -
63	2012	\$ 3,503,497	\$ 96,675	\$ 3,406,822	2012	\$ 3,117,703	\$ 94,770	\$ 3,022,933	\$ 223,550	\$ 1,104	\$ 222,446
64	2013	\$ 3,744,619	\$ 158,849	\$ 3,585,770	2013	\$ 3,117,703	\$ 147,385	\$ 2,970,318	\$ 363,269	\$ 6,643	\$ 356,626
65	2014	\$ 3,744,619	\$ 222,033	\$ 3,522,586	2014	\$ 3,117,703	\$ 199,857	\$ 2,917,846	\$ 363,269	\$ 12,917	\$ 350,352
66	2015	\$ 3,744,619	\$ 285,104	\$ 3,522,586	2015	\$ 3,117,703	\$ 252,368	\$ 2,865,335	\$ 363,269	\$ 19,036	\$ 344,233
67	2016	\$ 3,744,619	\$ 348,229	\$ 3,396,390	2016	\$ 3,117,703	\$ 304,925	\$ 2,812,778	\$ 363,269	\$ 25,160	\$ 338,109
68	2017	\$ -	\$ -	\$ -	2017	\$ -	\$ -	\$ -	\$ -	\$ -	\$ -
69	2018	\$ -	\$ -	\$ -	2018	\$ -	\$ -	\$ -	\$ -	\$ -	\$ -
70	2019	\$ -	\$ -	\$ -	2019	\$ -	\$ -	\$ -	\$ -	\$ -	\$ -
71	2020	\$ -	\$ -	\$ -	2020	\$ -	\$ -	\$ -	\$ -	\$ -	\$ -
72	2021	\$ -	\$ -	\$ -	2021	\$ -	\$ -	\$ -	\$ -	\$ -	\$ -
73	2022	\$ -	\$ -	\$ -	2022	\$ -	\$ -	\$ -	\$ -	\$ -	\$ -
74	2023	\$ -	\$ -	\$ -	2023	\$ -	\$ -	\$ -	\$ -	\$ -	\$ -
75	2024	\$ -	\$ -	\$ -	2024	\$ -	\$ -	\$ -	\$ -	\$ -	\$ -
76	2025	\$ -	\$ -	\$ -	2025	\$ -	\$ -	\$ -	\$ -	\$ -	\$ -
77	2026	\$ -	\$ -	\$ -	2026	\$ -	\$ -	\$ -	\$ -	\$ -	\$ -
78	2027	\$ -	\$ -	\$ -	2027	\$ -	\$ -	\$ -	\$ -	\$ -	\$ -
79	2028	\$ -	\$ -	\$ -	2028	\$ -	\$ -	\$ -	\$ -	\$ -	\$ -
80	2029	\$ -	\$ -	\$ -	2029	\$ -	\$ -	\$ -	\$ -	\$ -	\$ -
81	2030	\$ -	\$ -	\$ -	2030	\$ -	\$ -	\$ -	\$ -	\$ -	\$ -
82	2031	\$ -	\$ -	\$ -	2031	\$ -	\$ -	\$ -	\$ -	\$ -	\$ -
83	2032	\$ -	\$ -	\$ -	2032	\$ -	\$ -	\$ -	\$ -	\$ -	\$ -

- Notes:
- (B) See WP A-5 (Act Depreciation Rate).
 - (C) This rate will reflect any future KCC approved depreciation rates.
 - (D) BPF projects that have been completed and whose costs are in the KCC Annual Report should be entered on this page. If a project is completed in phases over multiple years, that project should be entered in sheet P-4 until the entire project is completed and reported in the KCC Annual Report.
 - (E) BPF projects with incentives granted by FERC should be included in Sheet A-9 as well as this sheet.
 - (F) Accumulated Depreciation will be brought forward from the prior year for each project.

**Sunflower Electric Power Corporation (SEPC)
Actual RTO Directed Transmission Projects
For the 12 months ended - December 31, 2016**

II. Calculation of Net Plant for Sunflower Owned Base Plan Funded Projects (cont'd):

		Project: 4			Project: 5			Project: 6				
		SPP Proj. ID			SPP Proj. ID			SPP Proj. ID				
Year	Month	Plant Balance by Month	Depr. Rate / 12 (notes B & C)	Depreciation Expense	Plant Balance by Month	Depr. Rate / 12 (notes B & C)	Depreciation Expense	Plant Balance by Month	Depr. Rate / 12 (notes B & C)	Depreciation Expense		
84	2015	Dec	\$ -		\$ -		\$ -					
85	2016	Jan	\$ -	0.1405%	\$ -	0.1405%	\$ -	\$ -	0.1405%	\$ -		
86	2016	Feb	\$ -	0.1405%	\$ -	0.1405%	\$ -	\$ -	0.1405%	\$ -		
87	2016	Mar	\$ -	0.1405%	\$ -	0.1405%	\$ -	\$ -	0.1405%	\$ -		
88	2016	Apr	\$ -	0.1405%	\$ -	0.1405%	\$ -	\$ -	0.1405%	\$ -		
89	2016	May	\$ -	0.1405%	\$ -	0.1405%	\$ -	\$ -	0.1405%	\$ -		
90	2016	Jun	\$ -	0.1405%	\$ -	0.1405%	\$ -	\$ -	0.1405%	\$ -		
91	2016	Jul	\$ -	0.1405%	\$ -	0.1405%	\$ -	\$ -	0.1405%	\$ -		
92	2016	Aug	\$ -	0.1405%	\$ -	0.1405%	\$ -	\$ -	0.1405%	\$ -		
93	2016	Sep	\$ -	0.1405%	\$ -	0.1405%	\$ -	\$ -	0.1405%	\$ -		
94	2016	Oct	\$ -	0.1405%	\$ -	0.1405%	\$ -	\$ -	0.1405%	\$ -		
95	2016	Nov	\$ -	0.1405%	\$ -	0.1405%	\$ -	\$ -	0.1405%	\$ -		
96	2016	Dec	\$ -	0.1405%	\$ -	0.1405%	\$ -	\$ -	0.1405%	\$ -		
97				Sum lines 85 - 96	\$ -	Sum lines 85 - 96			\$ -	Sum lines 85 - 96	\$ -	
98				2015 EOY		2015 EOY				2015 EOY		
99				Accum. Depr:		Accum. Depr:				Accum. Depr:		
100	Year	Total			Year	Total			Year	Total		
		Gross Plant	Accm. Deprac.	Net Plant		Gross Plant	Accm. Deprac.	Net Plant		Gross Plant	Accm. Deprac.	Net Plant
		<u>13 Month Averages</u>				<u>13 Month Averages</u>				<u>13 Month Averages</u>		
101	2010	\$ -	\$ -	\$ -	2010	\$ -	\$ -	\$ -	2010	\$ -	\$ -	\$ -
102	2011	\$ -	\$ -	\$ -	2011	\$ -	\$ -	\$ -	2011	\$ -	\$ -	\$ -
103	2012	\$ -	\$ -	\$ -	2012	\$ -	\$ -	\$ -	2012	\$ -	\$ -	\$ -
104	2013	\$ -	\$ -	\$ -	2013	\$ -	\$ -	\$ -	2013	\$ -	\$ -	\$ -
105	2014	\$ -	\$ -	\$ -	2014	\$ -	\$ -	\$ -	2014	\$ -	\$ -	\$ -
106	2015	\$ -	\$ -	\$ -	2015	\$ -	\$ -	\$ -	2015	\$ -	\$ -	\$ -
107	2016	\$ -	\$ -	\$ -	2016	\$ -	\$ -	\$ -	2016	\$ -	\$ -	\$ -
108	2017	\$ -	\$ -	\$ -	2017	\$ -	\$ -	\$ -	2017	\$ -	\$ -	\$ -
109	2018	\$ -	\$ -	\$ -	2018	\$ -	\$ -	\$ -	2018	\$ -	\$ -	\$ -
110	2019	\$ -	\$ -	\$ -	2019	\$ -	\$ -	\$ -	2019	\$ -	\$ -	\$ -
111	2020	\$ -	\$ -	\$ -	2020	\$ -	\$ -	\$ -	2020	\$ -	\$ -	\$ -
112	2021	\$ -	\$ -	\$ -	2021	\$ -	\$ -	\$ -	2021	\$ -	\$ -	\$ -
113	2022	\$ -	\$ -	\$ -	2022	\$ -	\$ -	\$ -	2022	\$ -	\$ -	\$ -
114	2023	\$ -	\$ -	\$ -	2023	\$ -	\$ -	\$ -	2023	\$ -	\$ -	\$ -
115	2024	\$ -	\$ -	\$ -	2024	\$ -	\$ -	\$ -	2024	\$ -	\$ -	\$ -
116	2025	\$ -	\$ -	\$ -	2025	\$ -	\$ -	\$ -	2025	\$ -	\$ -	\$ -
117	2026	\$ -	\$ -	\$ -	2026	\$ -	\$ -	\$ -	2026	\$ -	\$ -	\$ -
118	2027	\$ -	\$ -	\$ -	2027	\$ -	\$ -	\$ -	2027	\$ -	\$ -	\$ -
119	2028	\$ -	\$ -	\$ -	2028	\$ -	\$ -	\$ -	2028	\$ -	\$ -	\$ -
120	2029	\$ -	\$ -	\$ -	2029	\$ -	\$ -	\$ -	2029	\$ -	\$ -	\$ -
121	2030	\$ -	\$ -	\$ -	2030	\$ -	\$ -	\$ -	2030	\$ -	\$ -	\$ -
122	2031	\$ -	\$ -	\$ -	2031	\$ -	\$ -	\$ -	2031	\$ -	\$ -	\$ -
123	2032	\$ -	\$ -	\$ -	2032	\$ -	\$ -	\$ -	2032	\$ -	\$ -	\$ -

- Notes: (B) See WP A-5 (Act Depreciation Rate).
 (C) This rate will reflect any future KCC approved depreciation rates.
 (D) BPF projects that have been completed and whose costs are in the KCC Annual Report should be entered on this page. If a project is completed in phases over multiple years, that project should be entered in sheet P-4 until the entire
 (E) BPF projects with incentives granted by FERC should be included in Sheet A-9 as well as this sheet.
 (F) Accumulated Depreciation will be brought forward from the prior year for each project.

**Sunflower Electric Power Corporation (SEPC)
Actual RTO Directed Transmission Projects
For the 12 months ended - December 31, 2016**

III. Calculation of Net Plant for Capital Lease Base Plan Funded (BPF) Projects:

Holcomb to Fletcher 115kV Line (Wheatland)												
			Project: 1			Project: 2			Project: 3			
			SPP Proj. ID 899			SPP Proj. ID			SPP Proj. ID			
			Sum of monthly lease payments \$ 586,636			Sum of monthly lease payments \$ -			Sum of monthly lease payments			
Year	Month	Plant Balance by Month	Annual Rate	Equivalent Amortization Expense	Plant Balance by Month	Annual Rate	Equivalent Amortization Expense	Plant Balance by Month	Annual Rate	Equivalent Amortization Expense		
124	2015	Dec	\$ 4,091,866		\$ -		\$ -	\$ -		\$ -		
125	2016	Jan	\$ 4,091,866	7.15%	\$ 28,470	\$ -	\$ -	\$ -	0.00%	\$ -		
126	2016	Feb	\$ 4,091,866	7.15%	\$ 28,470	\$ -	\$ -	\$ -	0.00%	\$ -		
127	2016	Mar	\$ 4,091,866	7.15%	\$ 28,470	\$ -	\$ -	\$ -	0.00%	\$ -		
128	2016	Apr	\$ 4,091,866	7.15%	\$ 28,470	\$ -	\$ -	\$ -	0.00%	\$ -		
129	2016	May	\$ 4,091,866	7.15%	\$ 28,470	\$ -	\$ -	\$ -	0.00%	\$ -		
130	2016	Jun	\$ 4,091,866	7.15%	\$ 28,470	\$ -	\$ -	\$ -	0.00%	\$ -		
131	2016	Jul	\$ 4,091,866	7.15%	\$ 28,470	\$ -	\$ -	\$ -	0.00%	\$ -		
132	2016	Aug	\$ 4,091,866	7.15%	\$ 28,470	\$ -	\$ -	\$ -	0.00%	\$ -		
133	2016	Sep	\$ 4,091,866	7.15%	\$ 28,470	\$ -	\$ -	\$ -	0.00%	\$ -		
134	2016	Oct	\$ 4,091,866	7.15%	\$ 28,470	\$ -	\$ -	\$ -	0.00%	\$ -		
135	2016	Nov	\$ 4,091,866	7.15%	\$ 28,470	\$ -	\$ -	\$ -	0.00%	\$ -		
136	2016	Dec	\$ 4,091,866	7.15%	\$ 28,470	\$ -	\$ -	\$ -	0.00%	\$ -		
137			Sum lines 125 - 136	\$ 341,646		Sum lines 125 - 136	\$ -		Sum lines 125 - 136	\$ -		
138			2015 EOY		2015 EOY		2015 EOY		2015 EOY			
138			Accum. Amort:	665,432	Accum. Amort:	-	Accum. Amort:	-	Accum. Amort:	-		
139	Year	Total			Year	Total			Year	Total		
139		Gross Plant	Accm. Deprec.	Net Plant		Gross Plant	Accm. Depr.	Net Plant		Gross Plant	Accm. Depr.	Net Plant
140			13 Month Averages			13 Month Averages			13 Month Averages			
141	2010	\$ -	\$ -	\$ -	2010	\$ -	\$ -	\$ -	2010	\$ -	\$ -	\$ -
142	2011	\$ -	\$ -	\$ -	2011	\$ -	\$ -	\$ -	2011	\$ -	\$ -	\$ -
143	2012	\$ -	\$ -	\$ -	2012	\$ -	\$ -	\$ -	2012	\$ -	\$ -	\$ -
144	2013	\$ 340,989	\$ 5,655	\$ 335,334	2013	\$ 340,989	\$ 5,655	\$ 335,334	2013	\$ -	\$ -	\$ -
145	2014	\$ 4,091,866	\$ 197,798	\$ 3,894,068	2014	\$ 4,091,866	\$ 197,798	\$ 3,894,068	2014	\$ -	\$ -	\$ -
146	2015	\$ 4,091,866	\$ 506,008	\$ 3,585,858	2015	\$ 4,091,866	\$ 506,008	\$ 3,585,858	2015	\$ -	\$ -	\$ -
147	2016	\$ 4,091,866	\$ 836,255	\$ 3,255,611	2016	\$ 4,091,866	\$ 836,255	\$ 3,255,611	2016	\$ -	\$ -	\$ -
148	2017	\$ -	\$ -	\$ -	2017	\$ -	\$ -	\$ -	2017	\$ -	\$ -	\$ -
149	2018	\$ -	\$ -	\$ -	2018	\$ -	\$ -	\$ -	2018	\$ -	\$ -	\$ -
150	2019	\$ -	\$ -	\$ -	2019	\$ -	\$ -	\$ -	2019	\$ -	\$ -	\$ -
151	2020	\$ -	\$ -	\$ -	2020	\$ -	\$ -	\$ -	2020	\$ -	\$ -	\$ -
152	2021	\$ -	\$ -	\$ -	2021	\$ -	\$ -	\$ -	2021	\$ -	\$ -	\$ -
153	2022	\$ -	\$ -	\$ -	2022	\$ -	\$ -	\$ -	2022	\$ -	\$ -	\$ -
154	2023	\$ -	\$ -	\$ -	2023	\$ -	\$ -	\$ -	2023	\$ -	\$ -	\$ -
155	2024	\$ -	\$ -	\$ -	2024	\$ -	\$ -	\$ -	2024	\$ -	\$ -	\$ -
156	2025	\$ -	\$ -	\$ -	2025	\$ -	\$ -	\$ -	2025	\$ -	\$ -	\$ -
157	2026	\$ -	\$ -	\$ -	2026	\$ -	\$ -	\$ -	2026	\$ -	\$ -	\$ -
158	2027	\$ -	\$ -	\$ -	2027	\$ -	\$ -	\$ -	2027	\$ -	\$ -	\$ -
159	2028	\$ -	\$ -	\$ -	2028	\$ -	\$ -	\$ -	2028	\$ -	\$ -	\$ -
160	2029	\$ -	\$ -	\$ -	2029	\$ -	\$ -	\$ -	2029	\$ -	\$ -	\$ -
161	2030	\$ -	\$ -	\$ -	2030	\$ -	\$ -	\$ -	2030	\$ -	\$ -	\$ -
162	2031	\$ -	\$ -	\$ -	2031	\$ -	\$ -	\$ -	2031	\$ -	\$ -	\$ -
163	2032	\$ -	\$ -	\$ -	2032	\$ -	\$ -	\$ -	2032	\$ -	\$ -	\$ -

**Sunflower Electric Power Corporation (SEPC)
Actual RTO Directed Transmission Projects
For the 12 months ended - December 31, 2016**

IV. Calculation of Net Plant for Operating Lease Base Plan Funded (BPF) Projects:

		Holcomb to Plymell 115kV (MKEC)			Plymell to Pioneer Tap 115kV (MKEC)						
		Project: 1		Project: 2		Project: 3					
		SPP Proj. ID 166		SPP Proj. ID 367		SPP Proj. ID					
		Sum of monthly lease payments \$ 355,700		Sum of monthly lease payments \$ 452,047		Sum of monthly lease payments					
Year	Month	Plant Balance by Month	Equivalent Amortization Expense	Plant Balance by Month	Equivalent Amortization Expense	Plant Balance by Month	Equivalent Amortization Expense	Plant Balance by Month	Equivalent Amortization Expense		
164	2015	Dec	\$ 3,400,999		\$ 4,322,255		\$ -				
165	2016	Jan	\$ 3,400,999	\$ 3,932	\$ 4,322,255	\$ 4,996	\$ -		\$ -		
166	2016	Feb	\$ 3,400,999	\$ 3,932	\$ 4,322,255	\$ 4,996	\$ -		\$ -		
167	2016	Mar	\$ 3,400,999	\$ 3,932	\$ 4,322,255	\$ 4,996	\$ -		\$ -		
168	2016	Apr	\$ 3,400,999	\$ 3,932	\$ 4,322,255	\$ 4,996	\$ -		\$ -		
169	2016	May	\$ 3,400,999	\$ 3,932	\$ 4,322,255	\$ 4,996	\$ -		\$ -		
170	2016	Jun	\$ 3,400,999	\$ 3,932	\$ 4,322,255	\$ 4,996	\$ -		\$ -		
171	2016	Jul	\$ 3,400,999	\$ 4,189	\$ 4,322,255	\$ 5,324	\$ -		\$ -		
172	2016	Aug	\$ 3,400,999	\$ 4,189	\$ 4,322,255	\$ 5,324	\$ -		\$ -		
173	2016	Sep	\$ 3,400,999	\$ 4,189	\$ 4,322,255	\$ 5,324	\$ -		\$ -		
174	2016	Oct	\$ 3,400,999	\$ 4,189	\$ 4,322,255	\$ 5,324	\$ -		\$ -		
175	2016	Nov	\$ 3,400,999	\$ 4,190	\$ 4,322,255	\$ 5,325	\$ -		\$ -		
176	2016	Dec	\$ 3,400,999	\$ 4,190	\$ 4,322,255	\$ 5,325	\$ -		\$ -		
177			Sum lines 165 - 176 \$ 48,728		Sum lines 165 - 176 \$ 61,922		Sum lines 165 - 176 \$ -				
178			2015 EOY Accum. Amort: 148,419		2015 EOY Accum. Amort: 188,623		2015 EOY Accum. Amort: -				
Year	Total			Year	Total			Year	Total		
Year	Gross Plant	Accm. Deprec.	Net Plant	Year	Gross Plant	Accm. Depr.	Net Plant	Year	Gross Plant	Accm. Depr.	Net Plant
180	<u>13 Month Averages</u>			180	<u>13 Month Averages</u>			180	<u>13 Month Averages</u>		
181	2010	\$ -	\$ -	2010	\$ -	\$ -	\$ -	2010	\$ -	\$ -	\$ -
182	2011	\$ -	\$ -	2011	\$ -	\$ -	\$ -	2011	\$ -	\$ -	\$ -
183	2012	\$ 4,158,675	\$ 11,922	2012	\$ 1,831,307	\$ 5,250	\$ 1,826,057	2012	\$ 2,327,368	\$ 6,672	\$ 2,320,696
184	2013	\$ 7,723,254	\$ 89,340	2013	\$ 3,400,999	\$ 39,344	\$ 3,361,655	2013	\$ 4,322,255	\$ 49,996	\$ 4,272,259
185	2014	\$ 7,723,254	\$ 180,798	2014	\$ 3,400,999	\$ 79,622	\$ 3,321,377	2014	\$ 4,322,255	\$ 101,176	\$ 4,221,079
186	2015	\$ 7,723,254	\$ 272,256	2015	\$ 3,400,999	\$ 119,900	\$ 3,281,099	2015	\$ 4,322,255	\$ 152,356	\$ 4,169,899
187	2016	\$ 7,723,254	\$ 391,555	2016	\$ 3,400,999	\$ 172,426	\$ 3,228,573	2016	\$ 4,322,255	\$ 219,129	\$ 4,103,126
188	2017	\$ -	\$ -	2017	\$ -	\$ -	\$ -	2017	\$ -	\$ -	\$ -
189	2018	\$ -	\$ -	2018	\$ -	\$ -	\$ -	2018	\$ -	\$ -	\$ -
190	2019	\$ -	\$ -	2019	\$ -	\$ -	\$ -	2019	\$ -	\$ -	\$ -
191	2020	\$ -	\$ -	2020	\$ -	\$ -	\$ -	2020	\$ -	\$ -	\$ -
192	2021	\$ -	\$ -	2021	\$ -	\$ -	\$ -	2021	\$ -	\$ -	\$ -
193	2022	\$ -	\$ -	2022	\$ -	\$ -	\$ -	2022	\$ -	\$ -	\$ -
194	2023	\$ -	\$ -	2023	\$ -	\$ -	\$ -	2023	\$ -	\$ -	\$ -
195	2024	\$ -	\$ -	2024	\$ -	\$ -	\$ -	2024	\$ -	\$ -	\$ -
196	2025	\$ -	\$ -	2025	\$ -	\$ -	\$ -	2025	\$ -	\$ -	\$ -
197	2026	\$ -	\$ -	2026	\$ -	\$ -	\$ -	2026	\$ -	\$ -	\$ -
198	2027	\$ -	\$ -	2027	\$ -	\$ -	\$ -	2027	\$ -	\$ -	\$ -
199	2028	\$ -	\$ -	2028	\$ -	\$ -	\$ -	2028	\$ -	\$ -	\$ -
200	2029	\$ -	\$ -	2029	\$ -	\$ -	\$ -	2029	\$ -	\$ -	\$ -
201	2030	\$ -	\$ -	2030	\$ -	\$ -	\$ -	2030	\$ -	\$ -	\$ -
202	2031	\$ -	\$ -	2031	\$ -	\$ -	\$ -	2031	\$ -	\$ -	\$ -
203	2032	\$ -	\$ -	2032	\$ -	\$ -	\$ -	2032	\$ -	\$ -	\$ -

**Sunflower Electric Power Corporation (SEPC)
Actual RTO Directed Transmission Projects
For the 12 months ended - December 31, 2016**

V. Calculation of Net Plant for Balanced Portfolio (BP) Projects :

		Project: 7			Project: 8			Project: 9				
		SPP Proj. ID			SPP Proj. ID			SPP Proj. ID				
Year	Month	Plant Balance by Month	Depr. Rate / 12 (notes B & C)	Depreciation Expense	Plant Balance by Month	Depr. Rate / 12 (notes B & C)	Depreciation Expense	Plant Balance by Month	Depr. Rate / 12 (notes B & C)	Depreciation Expense		
204	2015	Dec	\$ -		\$ -		\$ -					
205	2016	Jan	\$ -	0.1405%	\$ -	0.1405%	\$ -	\$ -	0.1405%	\$ -		
206	2016	Feb	\$ -	0.1405%	\$ -	0.1405%	\$ -	\$ -	0.1405%	\$ -		
207	2016	Mar	\$ -	0.1405%	\$ -	0.1405%	\$ -	\$ -	0.1405%	\$ -		
208	2016	Apr	\$ -	0.1405%	\$ -	0.1405%	\$ -	\$ -	0.1405%	\$ -		
209	2016	May	\$ -	0.1405%	\$ -	0.1405%	\$ -	\$ -	0.1405%	\$ -		
210	2016	Jun	\$ -	0.1405%	\$ -	0.1405%	\$ -	\$ -	0.1405%	\$ -		
211	2016	Jul	\$ -	0.1405%	\$ -	0.1405%	\$ -	\$ -	0.1405%	\$ -		
212	2016	Aug	\$ -	0.1405%	\$ -	0.1405%	\$ -	\$ -	0.1405%	\$ -		
213	2016	Sep	\$ -	0.1405%	\$ -	0.1405%	\$ -	\$ -	0.1405%	\$ -		
214	2016	Oct	\$ -	0.1405%	\$ -	0.1405%	\$ -	\$ -	0.1405%	\$ -		
215	2016	Nov	\$ -	0.1405%	\$ -	0.1405%	\$ -	\$ -	0.1405%	\$ -		
216	2016	Dec	\$ -	0.1405%	\$ -	0.1405%	\$ -	\$ -	0.1405%	\$ -		
217				Sum lines 205 - 216	\$ -				Sum lines 205 - 216	\$ -		
218	Total			2015 EOY		2015 EOY		2015 EOY				
219	Year	Gross Plant	Accm. Deprac.	Net Plant	Year	Gross Plant	Accm. Deprac.	Net Plant	Year	Gross Plant	Accm. Deprac.	Net Plant
220	13 Month Averages			13 Month Averages			13 Month Averages			13 Month Averages		
221	2010	\$ -	\$ -	\$ -	2010	\$ -	\$ -	\$ -	2010	\$ -	\$ -	\$ -
222	2011	\$ -	\$ -	\$ -	2011	\$ -	\$ -	\$ -	2011	\$ -	\$ -	\$ -
223	2012	\$ -	\$ -	\$ -	2012	\$ -	\$ -	\$ -	2012	\$ -	\$ -	\$ -
224	2013	\$ -	\$ -	\$ -	2013	\$ -	\$ -	\$ -	2013	\$ -	\$ -	\$ -
225	2014	\$ -	\$ -	\$ -	2014	\$ -	\$ -	\$ -	2014	\$ -	\$ -	\$ -
226	2015	\$ -	\$ -	\$ -	2015	\$ -	\$ -	\$ -	2015	\$ -	\$ -	\$ -
227	2016	\$ -	\$ -	\$ -	2016	\$ -	\$ -	\$ -	2016	\$ -	\$ -	\$ -
228	2017	\$ -	\$ -	\$ -	2017	\$ -	\$ -	\$ -	2017	\$ -	\$ -	\$ -
229	2018	\$ -	\$ -	\$ -	2018	\$ -	\$ -	\$ -	2018	\$ -	\$ -	\$ -
230	2019	\$ -	\$ -	\$ -	2019	\$ -	\$ -	\$ -	2019	\$ -	\$ -	\$ -
231	2020	\$ -	\$ -	\$ -	2020	\$ -	\$ -	\$ -	2020	\$ -	\$ -	\$ -
232	2021	\$ -	\$ -	\$ -	2021	\$ -	\$ -	\$ -	2021	\$ -	\$ -	\$ -
233	2022	\$ -	\$ -	\$ -	2022	\$ -	\$ -	\$ -	2022	\$ -	\$ -	\$ -
234	2023	\$ -	\$ -	\$ -	2023	\$ -	\$ -	\$ -	2023	\$ -	\$ -	\$ -
235	2024	\$ -	\$ -	\$ -	2024	\$ -	\$ -	\$ -	2024	\$ -	\$ -	\$ -
236	2025	\$ -	\$ -	\$ -	2025	\$ -	\$ -	\$ -	2025	\$ -	\$ -	\$ -
237	2026	\$ -	\$ -	\$ -	2026	\$ -	\$ -	\$ -	2026	\$ -	\$ -	\$ -
238	2027	\$ -	\$ -	\$ -	2027	\$ -	\$ -	\$ -	2027	\$ -	\$ -	\$ -
239	2028	\$ -	\$ -	\$ -	2028	\$ -	\$ -	\$ -	2028	\$ -	\$ -	\$ -
240	2029	\$ -	\$ -	\$ -	2029	\$ -	\$ -	\$ -	2029	\$ -	\$ -	\$ -
241	2030	\$ -	\$ -	\$ -	2030	\$ -	\$ -	\$ -	2030	\$ -	\$ -	\$ -
242	2031	\$ -	\$ -	\$ -	2031	\$ -	\$ -	\$ -	2031	\$ -	\$ -	\$ -
243	2032	\$ -	\$ -	\$ -	2032	\$ -	\$ -	\$ -	2032	\$ -	\$ -	\$ -

- Notes: (B) See WP A-5 (Act Depreciation Rate).
 (C) This rate will reflect any future KCC approved depreciation rates.
 (D) BP projects that have been completed and whose costs are in the KCC Annual Report should be entered on this page. If a project is completed in phases over multiple years, that project should be entered in sheet P-4 until the entire project is completed and reported in the KCC Annual Report.
 (E) BP projects with incentives granted by FERC should be included in Sheet A-9 as well as this sheet.
 (F) Accumulated Depreciation will be brought forward from the prior year for each project.

**Sunflower Electric Power Corporation (SEPC)
Actual RTO Directed Transmission Projects
For the 12 months ended - December 31, 2016**

VI. Calculation of Net Plant for ITP / Priority 1 Projects

		Project: 1			Project: 2			Project: 3				
		SPP Proj. ID			SPP Proj. ID			SPP Proj. ID				
Year	Month	Plant Balance by Month	Depr. Rate / 12 (notes B & C)	Depreciation Expense	Plant Balance by Month	Depr. Rate / 12 (notes B & C)	Depreciation Expense	Plant Balance by Month	Depr. Rate / 12 (notes B & C)	Depreciation Expense		
244	2015	Dec	\$ -		\$ -			\$ -				
245	2016	Jan	\$ -	0.1405%	\$ -	0.1405%	\$ -	\$ -	0.1405%	\$ -		
246	2016	Feb	\$ -	0.1405%	\$ -	0.1405%	\$ -	\$ -	0.1405%	\$ -		
247	2016	Mar	\$ -	0.1405%	\$ -	0.1405%	\$ -	\$ -	0.1405%	\$ -		
248	2016	Apr	\$ -	0.1405%	\$ -	0.1405%	\$ -	\$ -	0.1405%	\$ -		
249	2016	May	\$ -	0.1405%	\$ -	0.1405%	\$ -	\$ -	0.1405%	\$ -		
250	2016	Jun	\$ -	0.1405%	\$ -	0.1405%	\$ -	\$ -	0.1405%	\$ -		
251	2016	Jul	\$ -	0.1405%	\$ -	0.1405%	\$ -	\$ -	0.1405%	\$ -		
252	2016	Aug	\$ -	0.1405%	\$ -	0.1405%	\$ -	\$ -	0.1405%	\$ -		
253	2016	Sep	\$ -	0.1405%	\$ -	0.1405%	\$ -	\$ -	0.1405%	\$ -		
254	2016	Oct	\$ -	0.1405%	\$ -	0.1405%	\$ -	\$ -	0.1405%	\$ -		
255	2016	Nov	\$ -	0.1405%	\$ -	0.1405%	\$ -	\$ -	0.1405%	\$ -		
256	2016	Dec	\$ -	0.1405%	\$ -	0.1405%	\$ -	\$ -	0.1405%	\$ -		
257	Sum lines 245 - 256			\$ -	Sum lines 245 - 256			\$ -	Sum lines 245 - 256			\$ -
258	2015 EOY Accum. Depr:			-	2015 EOY Accum. Depr:			-	2015 EOY Accum. Depr:			-
Year	Total			Year	Total			Year	Total			Year
	Gross Plant	Accm. Deprac.	Net Plant		Gross Plant	Accm. Deprac.	Net Plant		Gross Plant	Accm. Deprac.	Net Plant	
260	13 Month Averages				13 Month Averages				13 Month Averages			
261	2010	\$ -	\$ -	\$ -	2010	\$ -	\$ -	\$ -	\$ -	\$ -	\$ -	\$ -
262	2011	\$ -	\$ -	\$ -	2011	\$ -	\$ -	\$ -	\$ -	\$ -	\$ -	\$ -
263	2012	\$ -	\$ -	\$ -	2012	\$ -	\$ -	\$ -	\$ -	\$ -	\$ -	\$ -
264	2013	\$ -	\$ -	\$ -	2013	\$ -	\$ -	\$ -	\$ -	\$ -	\$ -	\$ -
265	2014	\$ -	\$ -	\$ -	2014	\$ -	\$ -	\$ -	\$ -	\$ -	\$ -	\$ -
266	2015	\$ -	\$ -	\$ -	2015	\$ -	\$ -	\$ -	\$ -	\$ -	\$ -	\$ -
267	2016	\$ -	\$ -	\$ -	2016	\$ -	\$ -	\$ -	\$ -	\$ -	\$ -	\$ -
268	2017	\$ -	\$ -	\$ -	2017	\$ -	\$ -	\$ -	\$ -	\$ -	\$ -	\$ -
269	2018	\$ -	\$ -	\$ -	2018	\$ -	\$ -	\$ -	\$ -	\$ -	\$ -	\$ -
270	2019	\$ -	\$ -	\$ -	2019	\$ -	\$ -	\$ -	\$ -	\$ -	\$ -	\$ -
271	2020	\$ -	\$ -	\$ -	2020	\$ -	\$ -	\$ -	\$ -	\$ -	\$ -	\$ -
272	2021	\$ -	\$ -	\$ -	2021	\$ -	\$ -	\$ -	\$ -	\$ -	\$ -	\$ -
273	2022	\$ -	\$ -	\$ -	2022	\$ -	\$ -	\$ -	\$ -	\$ -	\$ -	\$ -
274	2023	\$ -	\$ -	\$ -	2023	\$ -	\$ -	\$ -	\$ -	\$ -	\$ -	\$ -
275	2024	\$ -	\$ -	\$ -	2024	\$ -	\$ -	\$ -	\$ -	\$ -	\$ -	\$ -
276	2025	\$ -	\$ -	\$ -	2025	\$ -	\$ -	\$ -	\$ -	\$ -	\$ -	\$ -
277	2026	\$ -	\$ -	\$ -	2026	\$ -	\$ -	\$ -	\$ -	\$ -	\$ -	\$ -
278	2027	\$ -	\$ -	\$ -	2027	\$ -	\$ -	\$ -	\$ -	\$ -	\$ -	\$ -
279	2028	\$ -	\$ -	\$ -	2028	\$ -	\$ -	\$ -	\$ -	\$ -	\$ -	\$ -
280	2029	\$ -	\$ -	\$ -	2029	\$ -	\$ -	\$ -	\$ -	\$ -	\$ -	\$ -
281	2030	\$ -	\$ -	\$ -	2030	\$ -	\$ -	\$ -	\$ -	\$ -	\$ -	\$ -
282	2031	\$ -	\$ -	\$ -	2031	\$ -	\$ -	\$ -	\$ -	\$ -	\$ -	\$ -
283	2032	\$ -	\$ -	\$ -	2032	\$ -	\$ -	\$ -	\$ -	\$ -	\$ -	\$ -

- Notes: (B) See WP A-5 (Act Depreciation Rate).
 (C) This rate will reflect any future KCC approved depreciation rates.
 (D) ITP/Priority 1 projects that have been completed and whose costs are in the KCC Annual Report should be entered on this page. If a project is completed in phases over multiple years, that project should be entered in sheet P-4 until the entire project is completed and reported in the KCC Annual Report.
 (E) ITP/Priority 1 Project with incentives granted by FERC should be included in Sheet A-9 as well as this sheet.
 (F) Accumulated Depreciation will be brought forward from the prior year for each project.

**Sunflower Electric Power Corporation (SEPC)
Actual RTO Directed Transmission Projects
For the 12 months ended - December 31, 2016**

VII. Calculation of Net Plant for ITP / Priority 2 Projects

		Project: 1			Project: 2			Project: 3				
		SPP Proj. ID			SPP Proj. ID			SPP Proj. ID				
Year	Month	Plant Balance by Month	Depr. Rate / 12 (notes B & C)	Depreciation Expense	Plant Balance by Month	Depr. Rate / 12 (notes B & C)	Depreciation Expense	Plant Balance by Month	Depr. Rate / 12 (notes B & C)	Depreciation Expense		
284	2015	Dec	\$ -		\$ -		\$ -					
285	2016	Jan	\$ -	0.1405%	\$ -	0.1405%	\$ -	\$ -	0.1405%	\$ -		
286	2016	Feb	\$ -	0.1405%	\$ -	0.1405%	\$ -	\$ -	0.1405%	\$ -		
287	2016	Mar	\$ -	0.1405%	\$ -	0.1405%	\$ -	\$ -	0.1405%	\$ -		
288	2016	Apr	\$ -	0.1405%	\$ -	0.1405%	\$ -	\$ -	0.1405%	\$ -		
289	2016	May	\$ -	0.1405%	\$ -	0.1405%	\$ -	\$ -	0.1405%	\$ -		
290	2016	Jun	\$ -	0.1405%	\$ -	0.1405%	\$ -	\$ -	0.1405%	\$ -		
291	2016	Jul	\$ -	0.1405%	\$ -	0.1405%	\$ -	\$ -	0.1405%	\$ -		
292	2016	Aug	\$ -	0.1405%	\$ -	0.1405%	\$ -	\$ -	0.1405%	\$ -		
293	2016	Sep	\$ -	0.1405%	\$ -	0.1405%	\$ -	\$ -	0.1405%	\$ -		
294	2016	Oct	\$ -	0.1405%	\$ -	0.1405%	\$ -	\$ -	0.1405%	\$ -		
295	2016	Nov	\$ -	0.1405%	\$ -	0.1405%	\$ -	\$ -	0.1405%	\$ -		
296	2016	Dec	\$ -	0.1405%	\$ -	0.1405%	\$ -	\$ -	0.1405%	\$ -		
297				Sum lines 285 - 296	\$ -				Sum lines 285 - 296	\$ -		
298	Total			2015 EOY		2015 EOY		2015 EOY				
299	Year	Gross Plant	Accm. Deprac.	Net Plant	Year	Gross Plant	Accm. Deprac.	Net Plant	Year	Gross Plant	Accm. Deprac.	Net Plant
300	13 Month Averages			13 Month Averages			13 Month Averages			13 Month Averages		
301	2010	\$ -	\$ -	\$ -	2010	\$ -	\$ -	\$ -	2010	\$ -	\$ -	\$ -
302	2011	\$ -	\$ -	\$ -	2011	\$ -	\$ -	\$ -	2011	\$ -	\$ -	\$ -
303	2012	\$ -	\$ -	\$ -	2012	\$ -	\$ -	\$ -	2012	\$ -	\$ -	\$ -
304	2013	\$ -	\$ -	\$ -	2013	\$ -	\$ -	\$ -	2013	\$ -	\$ -	\$ -
305	2014	\$ -	\$ -	\$ -	2014	\$ -	\$ -	\$ -	2014	\$ -	\$ -	\$ -
306	2015	\$ -	\$ -	\$ -	2015	\$ -	\$ -	\$ -	2015	\$ -	\$ -	\$ -
307	2016	\$ -	\$ -	\$ -	2016	\$ -	\$ -	\$ -	2016	\$ -	\$ -	\$ -
308	2017	\$ -	\$ -	\$ -	2017	\$ -	\$ -	\$ -	2017	\$ -	\$ -	\$ -
309	2018	\$ -	\$ -	\$ -	2018	\$ -	\$ -	\$ -	2018	\$ -	\$ -	\$ -
310	2019	\$ -	\$ -	\$ -	2019	\$ -	\$ -	\$ -	2019	\$ -	\$ -	\$ -
311	2020	\$ -	\$ -	\$ -	2020	\$ -	\$ -	\$ -	2020	\$ -	\$ -	\$ -
312	2021	\$ -	\$ -	\$ -	2021	\$ -	\$ -	\$ -	2021	\$ -	\$ -	\$ -
313	2022	\$ -	\$ -	\$ -	2022	\$ -	\$ -	\$ -	2022	\$ -	\$ -	\$ -
314	2023	\$ -	\$ -	\$ -	2023	\$ -	\$ -	\$ -	2023	\$ -	\$ -	\$ -
315	2024	\$ -	\$ -	\$ -	2024	\$ -	\$ -	\$ -	2024	\$ -	\$ -	\$ -
316	2025	\$ -	\$ -	\$ -	2025	\$ -	\$ -	\$ -	2025	\$ -	\$ -	\$ -
317	2026	\$ -	\$ -	\$ -	2026	\$ -	\$ -	\$ -	2026	\$ -	\$ -	\$ -
318	2027	\$ -	\$ -	\$ -	2027	\$ -	\$ -	\$ -	2027	\$ -	\$ -	\$ -
319	2028	\$ -	\$ -	\$ -	2028	\$ -	\$ -	\$ -	2028	\$ -	\$ -	\$ -
320	2029	\$ -	\$ -	\$ -	2029	\$ -	\$ -	\$ -	2029	\$ -	\$ -	\$ -
321	2030	\$ -	\$ -	\$ -	2030	\$ -	\$ -	\$ -	2030	\$ -	\$ -	\$ -
322	2031	\$ -	\$ -	\$ -	2031	\$ -	\$ -	\$ -	2031	\$ -	\$ -	\$ -
323	2032	\$ -	\$ -	\$ -	2032	\$ -	\$ -	\$ -	2032	\$ -	\$ -	\$ -

- Notes: (B) See WP A-5 (Act Depreciation Rate).
 (C) This rate will reflect any future KCC approved depreciation rates.
 (D) ITP/Priority 2 projects that have been completed and whose costs are in the KCC Annual Report should be entered on this page. If a project is completed in phases over multiple years, that project should be entered in sheet P-4 until the entire project is completed and reported in the KCC Annual Report.
 (E) ITP/Priority 2 Project with incentives granted by FERC should be included in Sheet A-9 as well as this sheet.
 (F) Accumulated Depreciation will be brought forward from the prior year for each project.

**Sunflower Electric Power Corporation (SEPC)
Actual Sponsored Upgrades
For the 12 months ended - December 31, 2016**

I. Summary of Actual Sponsored Projects

Note: Line numbers in the table below refer to Workpaper A-7 (Act. RTO Directed Proj)

(a) Project No.	(b) Project ID	(c) Description	(d) In Service Date	(e) Gross Plant (see below)	(f) Net Plant (see below)	(g) O&M and A&G Expense (f * L8)	(h) Other Taxes (f * L10)	(i) General Plant Allocation (f * L15)	(j) Depreciation Expense (see below)	(k) Non Incentive Return (f * L16)	(l) Incentive Return (WP A-9)	(m) Revenue Requirements (g + h + i + j+ k +l)
1	1	0	0	\$ -	\$ -	\$ -	\$ -	\$ -	\$ -	\$ -	\$ -	\$ -
2	2	0	0	\$ -	\$ -	\$ -	\$ -	\$ -	\$ -	\$ -	\$ -	\$ -
3	3	0	0	\$ -	\$ -	\$ -	\$ -	\$ -	\$ -	\$ -	\$ -	\$ -
4	Total			\$ -	\$ -	\$ -	\$ -	\$ -	\$ -	\$ -	\$ -	\$ -

II. Calculation of Net Plant for Sponsored Upgrade:

Year	Month	Project: 1			Project: 2			Project: 3							
		SPP Proj. ID	Plant Balance by Month	Depr. Rate / 12 (notes A & B)	Depreciation Expense	SPP Proj. ID	Plant Balance by Month	Depr. Rate / 12 (notes A & B)	Depreciation Expense	SPP Proj. ID	Plant Balance by Month	Depr. Rate / 12 (notes A & B)	Depreciation Expense		
2015	Dec		\$ -		\$ -			\$ -				\$ -			
2016	Jan		\$ -	0.1405%	\$ -			\$ -			0.1405%	\$ -			
2016	Feb		\$ -	0.1405%	\$ -			\$ -			0.1405%	\$ -			
2016	Mar		\$ -	0.1405%	\$ -			\$ -			0.1405%	\$ -			
2016	Apr		\$ -	0.1405%	\$ -			\$ -			0.1405%	\$ -			
2016	May		\$ -	0.1405%	\$ -			\$ -			0.1405%	\$ -			
2016	Jun		\$ -	0.1405%	\$ -			\$ -			0.1405%	\$ -			
2016	Jul		\$ -	0.1405%	\$ -			\$ -			0.1405%	\$ -			
2016	Aug		\$ -	0.1405%	\$ -			\$ -			0.1405%	\$ -			
2016	Sep		\$ -	0.1405%	\$ -			\$ -			0.1405%	\$ -			
2016	Oct		\$ -	0.1405%	\$ -			\$ -			0.1405%	\$ -			
2016	Nov		\$ -	0.1405%	\$ -			\$ -			0.1405%	\$ -			
2016	Dec		\$ -	0.1405%	\$ -			\$ -			0.1405%	\$ -			
			2015 EOY Accum. Depr: -				2015 EOY Accum. Depr: -				2015 EOY Accum. Depr: -				
Year	Total			Year	Total			Year	Total			Year	Total		
	Gross Plant	Accm. Deprac.	Net Plant		Gross Plant	Accm. Deprac.	Net Plant		Gross Plant	Accm. Deprac.	Net Plant		Gross Plant	Accm. Deprac.	Net Plant
	13 Month Averages				13 Month Averages				13 Month Averages				13 Month Averages		
2010	\$ -	\$ -	\$ -	2010	\$ -	\$ -	\$ -	2010	\$ -	\$ -	\$ -	2010	\$ -	\$ -	\$ -
2011	\$ -	\$ -	\$ -	2011	\$ -	\$ -	\$ -	2011	\$ -	\$ -	\$ -	2011	\$ -	\$ -	\$ -
2012	\$ -	\$ -	\$ -	2012	\$ -	\$ -	\$ -	2012	\$ -	\$ -	\$ -	2012	\$ -	\$ -	\$ -
2013	\$ -	\$ -	\$ -	2013	\$ -	\$ -	\$ -	2013	\$ -	\$ -	\$ -	2013	\$ -	\$ -	\$ -
2014	\$ -	\$ -	\$ -	2014	\$ -	\$ -	\$ -	2014	\$ -	\$ -	\$ -	2014	\$ -	\$ -	\$ -
2015	\$ -	\$ -	\$ -	2015	\$ -	\$ -	\$ -	2015	\$ -	\$ -	\$ -	2015	\$ -	\$ -	\$ -
2016	\$ -	\$ -	\$ -	2016	\$ -	\$ -	\$ -	2016	\$ -	\$ -	\$ -	2016	\$ -	\$ -	\$ -
2017	\$ -	\$ -	\$ -	2017	\$ -	\$ -	\$ -	2017	\$ -	\$ -	\$ -	2017	\$ -	\$ -	\$ -
2018	\$ -	\$ -	\$ -	2018	\$ -	\$ -	\$ -	2018	\$ -	\$ -	\$ -	2018	\$ -	\$ -	\$ -
2019	\$ -	\$ -	\$ -	2019	\$ -	\$ -	\$ -	2019	\$ -	\$ -	\$ -	2019	\$ -	\$ -	\$ -
2020	\$ -	\$ -	\$ -	2020	\$ -	\$ -	\$ -	2020	\$ -	\$ -	\$ -	2020	\$ -	\$ -	\$ -
2021	\$ -	\$ -	\$ -	2021	\$ -	\$ -	\$ -	2021	\$ -	\$ -	\$ -	2021	\$ -	\$ -	\$ -
2022	\$ -	\$ -	\$ -	2022	\$ -	\$ -	\$ -	2022	\$ -	\$ -	\$ -	2022	\$ -	\$ -	\$ -
2023	\$ -	\$ -	\$ -	2023	\$ -	\$ -	\$ -	2023	\$ -	\$ -	\$ -	2023	\$ -	\$ -	\$ -
2024	\$ -	\$ -	\$ -	2024	\$ -	\$ -	\$ -	2024	\$ -	\$ -	\$ -	2024	\$ -	\$ -	\$ -
2025	\$ -	\$ -	\$ -	2025	\$ -	\$ -	\$ -	2025	\$ -	\$ -	\$ -	2025	\$ -	\$ -	\$ -
2026	\$ -	\$ -	\$ -	2026	\$ -	\$ -	\$ -	2026	\$ -	\$ -	\$ -	2026	\$ -	\$ -	\$ -
2027	\$ -	\$ -	\$ -	2027	\$ -	\$ -	\$ -	2027	\$ -	\$ -	\$ -	2027	\$ -	\$ -	\$ -
2028	\$ -	\$ -	\$ -	2028	\$ -	\$ -	\$ -	2028	\$ -	\$ -	\$ -	2028	\$ -	\$ -	\$ -
2029	\$ -	\$ -	\$ -	2029	\$ -	\$ -	\$ -	2029	\$ -	\$ -	\$ -	2029	\$ -	\$ -	\$ -
2030	\$ -	\$ -	\$ -	2030	\$ -	\$ -	\$ -	2030	\$ -	\$ -	\$ -	2030	\$ -	\$ -	\$ -
2031	\$ -	\$ -	\$ -	2031	\$ -	\$ -	\$ -	2031	\$ -	\$ -	\$ -	2031	\$ -	\$ -	\$ -
2032	\$ -	\$ -	\$ -	2032	\$ -	\$ -	\$ -	2032	\$ -	\$ -	\$ -	2032	\$ -	\$ -	\$ -

- Notes:**
- (A) See WP A-5 (Act Depreciation Rate).
 - (B) This rate will reflect any future KCC approved depreciation rates.
 - (C) Sponsored Upgrade Projects that have been completed and whose costs are in the KCC Annual Report should be entered on this page. If a project is completed in phases over multiple years, that project should be entered in sheet P-4 until the entire project is completed and reported in the Annual Report.
 - (D) Sponsored Projects with incentives granted by FERC should be included in Sheet A-9 as well as this sheet.
 - (E) Accumulated Depreciation will be brought forward from the prior year for each project.

Sunflower Electric Power Corporation (SEPC)
Actual Incentive Plant
For the 12 months ended - December 31, 2016

I. Summary of Actual Incentive Projects

		Average Return New Debt 8.32% Source: WP A-7, L16				
(a)	(b)	(c)	(d)	(e)	(f)	
Project No.	Project ID	Description	In Service Date	Incentive Gross Plant (see below)	Incentive Plant Depr. Res. (see below)	Incentive Return Adder (see below)
<u>A. Base Plan Projects</u>						
1	1 0			\$ -	\$ -	\$ -
2	2 0			\$ -	\$ -	\$ -
3	3 0			\$ -	\$ -	\$ -
4	4 0			\$ -	\$ -	\$ -
5	5 0			\$ -	\$ -	\$ -
6	6 0			\$ -	\$ -	\$ -
7	Total			\$ -	\$ -	\$ -
<u>B. Balanced Portfolio Projects</u>						
8	1 0			\$ -	\$ -	\$ -
9	2 0			\$ -	\$ -	\$ -
10	3 0			\$ -	\$ -	\$ -
11	Total			\$ -	\$ -	\$ -
<u>C. ITP Priority #1 Projects</u>						
12	1 0			\$ -	\$ -	\$ -
13	2 0			\$ -	\$ -	\$ -
14	3 0			\$ -	\$ -	\$ -
15	Total			\$ -	\$ -	\$ -
<u>D. ITP Priority #2 Projects</u>						
15	1 0			\$ -	\$ -	\$ -
16	2 0			\$ -	\$ -	\$ -
17	3 0			\$ -	\$ -	\$ -
18	Total			\$ -	\$ -	\$ -
<u>E. Sponsored Projects</u>						
19	1 0			\$ -	\$ -	\$ -
20	2 0			\$ -	\$ -	\$ -
21	3 0			\$ -	\$ -	\$ -
22	Total			\$ -	\$ -	\$ -
<u>F. Third Party Projects</u>						
23	1 0			\$ -	\$ -	\$ -
24	2 0			\$ -	\$ -	\$ -
25	3 0			\$ -	\$ -	\$ -
26	Total			\$ -	\$ -	\$ -
27	Total for All Incentive Projects			\$ -	\$ -	\$ -

(A) Special incentive (Depreciation Rate, TIER, or DSC) may be utilized for specific incentive transmission projects if approved by the FERC.

(B) The formula is set up to accommodate an incentive DSC Adder. If FERC grants an ROE adder, it may be converted to a TIER adder using the following formula: TIER Adder = (ROE Adder * Equity Ratio) / Average System Interest Rate, or to a DSC adder using the following formula: DSC Adder = (ROE Adder * Equity ratio) / Average System Debt Service. If FERC grants a different incentive, the formula may need to be modified accordingly.

Sunflower Electric Power Corporation (SEPC)
Actual Incentive Plant
For the 12 months ended - December 31, 2016

II. Base Plan Projects (continued)

		Project: 4				Project: 5				Project: 6							
		SPP Proj. ID		DSC Adder (B)		SPP Proj. ID		DSC Adder (B)		SPP Proj. ID		DSC Adder (B)					
				4.7556%				4.7556%				4.7556%					
				0.0000%				0.0000%				0.0000%					
Year	Month	Plant Balance by Month	Deprec. Rate / 12	Depreciation Expense		Plant Balance by Month	Deprec. Rate / 12	Depreciation Expense		Plant Balance by Month	Deprec. Rate / 12	Depreciation Expense					
2015	Dec	\$ -		\$ -		\$ -		\$ -		\$ -		\$ -					
2016	Jan	\$ -	0.1405%	\$ -		\$ -	0.1405%	\$ -		\$ -	0.1405%	\$ -					
2016	Feb	\$ -	0.1405%	\$ -		\$ -	0.1405%	\$ -		\$ -	0.1405%	\$ -					
2016	Mar	\$ -	0.1405%	\$ -		\$ -	0.1405%	\$ -		\$ -	0.1405%	\$ -					
2016	Apr	\$ -	0.1405%	\$ -		\$ -	0.1405%	\$ -		\$ -	0.1405%	\$ -					
2016	May	\$ -	0.1405%	\$ -		\$ -	0.1405%	\$ -		\$ -	0.1405%	\$ -					
2016	Jun	\$ -	0.1405%	\$ -		\$ -	0.1405%	\$ -		\$ -	0.1405%	\$ -					
2016	Jul	\$ -	0.1405%	\$ -		\$ -	0.1405%	\$ -		\$ -	0.1405%	\$ -					
2016	Aug	\$ -	0.1405%	\$ -		\$ -	0.1405%	\$ -		\$ -	0.1405%	\$ -					
2016	Sep	\$ -	0.1405%	\$ -		\$ -	0.1405%	\$ -		\$ -	0.1405%	\$ -					
2016	Oct	\$ -	0.1405%	\$ -		\$ -	0.1405%	\$ -		\$ -	0.1405%	\$ -					
2016	Nov	\$ -	0.1405%	\$ -		\$ -	0.1405%	\$ -		\$ -	0.1405%	\$ -					
2016	Dec	\$ -	0.1405%	\$ -		\$ -	0.1405%	\$ -		\$ -	0.1405%	\$ -					
		Sum lines 77 - \$ -				Sum lines 77 - \$ -				Sum lines 77 - \$ -							
		2015 EOY Acc Dep: \$ -				2015 EOY Acc Dep: \$ -				2015 EOY Acc Dep: \$ -							
Year		Gross Plant	Accum. Depr.	Net Plant	Incentive Return Adder	Year		Gross Plant	Accum. Depr.	Net Plant	Incentive Return Adder	Year		Gross Plant	Accum. Depr.	Net Plant	Incentive Return Adder
		13 Month Averages				13 Month Averages				13 Month Averages							
2010		\$ -	\$ -	\$ -	\$ -	2010		\$ -	\$ -	\$ -	\$ -	2010		\$ -	\$ -	\$ -	\$ -
2011		\$ -	\$ -	\$ -	\$ -	2011		\$ -	\$ -	\$ -	\$ -	2011		\$ -	\$ -	\$ -	\$ -
2012				\$ -	\$ -	2012				\$ -	\$ -	2012				\$ -	\$ -
2013				\$ -	\$ -	2013				\$ -	\$ -	2013				\$ -	\$ -
2014				\$ -	\$ -	2014				\$ -	\$ -	2014				\$ -	\$ -
2015				\$ -	\$ -	2015				\$ -	\$ -	2015				\$ -	\$ -
2016				\$ -	\$ -	2016				\$ -	\$ -	2016				\$ -	\$ -
2017				\$ -	\$ -	2017				\$ -	\$ -	2017				\$ -	\$ -
2018				\$ -	\$ -	2018				\$ -	\$ -	2018				\$ -	\$ -
2019				\$ -	\$ -	2019				\$ -	\$ -	2019				\$ -	\$ -
2020				\$ -	\$ -	2020				\$ -	\$ -	2020				\$ -	\$ -
2021				\$ -	\$ -	2021				\$ -	\$ -	2021				\$ -	\$ -
2022				\$ -	\$ -	2022				\$ -	\$ -	2022				\$ -	\$ -
2023				\$ -	\$ -	2023				\$ -	\$ -	2023				\$ -	\$ -
2024				\$ -	\$ -	2024				\$ -	\$ -	2024				\$ -	\$ -
2025				\$ -	\$ -	2025				\$ -	\$ -	2025				\$ -	\$ -
2026				\$ -	\$ -	2026				\$ -	\$ -	2026				\$ -	\$ -
2027				\$ -	\$ -	2027				\$ -	\$ -	2027				\$ -	\$ -
2028				\$ -	\$ -	2028				\$ -	\$ -	2028				\$ -	\$ -
2029				\$ -	\$ -	2029				\$ -	\$ -	2029				\$ -	\$ -
2030				\$ -	\$ -	2030				\$ -	\$ -	2030				\$ -	\$ -
2031				\$ -	\$ -	2031				\$ -	\$ -	2031				\$ -	\$ -
2032				\$ -	\$ -	2032				\$ -	\$ -	2032				\$ -	\$ -

(A) Special incentive (Depreciation Rate, TIER, or DSC) may be utilized for specific incentive transmission projects if approved by the FERC.

(B) The formula is set up to accommodate an incentive DSC Adder. If FERC grants an ROE adder, it may be converted to a TIER adder using the following formula: TIER Adder = (ROE Adder * Equity Ratio) / Average System Interest Rate, or to a DSC adder using the following formula: DSC Adder = (ROE Adder * Equity ratio) / Average System Debt Service. If FERC grants a different incentive, the formula may need to be modified accordingly.

**Sunflower Electric Power Corporation (SEPC)
Actual Transmission Plant Related to Third Party Projects
For the 12 months ended - December 31, 2016**

I. Summary of Actual Projects Constructed by SEPC on Behalf of Third Parties

Note: Line numbers in the table below refer to Workpaper A-7 (Act. RTO Directed Proj)

(a) Line No.	(b) Project No.	(c) Project ID	(d) Description	(e) Third Party	(f) In Service Date	(g) Gross Plant (see below)	(h) Net Plant (see below)	(i) O&M and A&G Expense (g * L8)	(j) Other Taxes (g * L10)	(k) General Plant Allocation (g * L15)	(l) Depreciation Expense (see below)	(m) Non Incentive Return (g * L16)	(n) Incentive Return (WP A-9)	(o) Revenue Requirements (h + i + j+ k +l + m)
1	1	0	0	0		\$ -	\$ -	\$ -	\$ -	\$ -	\$ -	\$ -	\$ -	\$ -
2	2	0	0	0		\$ -	\$ -	\$ -	\$ -	\$ -	\$ -	\$ -	\$ -	\$ -
3	3	0	0	0		\$ -	\$ -	\$ -	\$ -	\$ -	\$ -	\$ -	\$ -	\$ -
4	Total					\$ -	\$ -	\$ -	\$ -	\$ -	\$ -	\$ -	\$ -	\$ -

II. Calculation of Net Plant for Projects Constructed by SEPC for Third Parties:

Line No.	Year	Month	Project: 1			Project: 2			Project: 3					
			Plant Balance by Month	Depr. Rate/12 (Notes A & B)	Depreciation Expense	Plant Balance by Month	Depr. Rate/12 (Notes A & B)	Depreciation Expense	Plant Balance by Month	Depr. Rate/12 (Notes A & B)	Depreciation Expense			
5			Project: 1			Project: 2			Project: 3					
6			SPP Proj. ID			SPP Proj. ID			SPP Proj. ID					
			Third Party			Third Party			Third Party					
7	2015	Dec	\$ -		\$ -	\$ -		\$ -	\$ -		\$ -		\$ -	
8	2016	Jan	\$ -	0.1405%	\$ -	\$ -	0.1405%	\$ -	\$ -	0.1405%	\$ -	0.1405%	\$ -	
9	2016	Feb	\$ -	0.1405%	\$ -	\$ -	0.1405%	\$ -	\$ -	0.1405%	\$ -	0.1405%	\$ -	
10	2016	Mar	\$ -	0.1405%	\$ -	\$ -	0.1405%	\$ -	\$ -	0.1405%	\$ -	0.1405%	\$ -	
11	2016	Apr	\$ -	0.1405%	\$ -	\$ -	0.1405%	\$ -	\$ -	0.1405%	\$ -	0.1405%	\$ -	
12	2016	May	\$ -	0.1405%	\$ -	\$ -	0.1405%	\$ -	\$ -	0.1405%	\$ -	0.1405%	\$ -	
13	2016	Jun	\$ -	0.1405%	\$ -	\$ -	0.1405%	\$ -	\$ -	0.1405%	\$ -	0.1405%	\$ -	
14	2016	Jul	\$ -	0.1405%	\$ -	\$ -	0.1405%	\$ -	\$ -	0.1405%	\$ -	0.1405%	\$ -	
15	2016	Aug	\$ -	0.1405%	\$ -	\$ -	0.1405%	\$ -	\$ -	0.1405%	\$ -	0.1405%	\$ -	
16	2016	Sep	\$ -	0.1405%	\$ -	\$ -	0.1405%	\$ -	\$ -	0.1405%	\$ -	0.1405%	\$ -	
17	2016	Oct	\$ -	0.1405%	\$ -	\$ -	0.1405%	\$ -	\$ -	0.1405%	\$ -	0.1405%	\$ -	
18	2016	Nov	\$ -	0.1405%	\$ -	\$ -	0.1405%	\$ -	\$ -	0.1405%	\$ -	0.1405%	\$ -	
19	2016	Dec	\$ -	0.1405%	\$ -	\$ -	0.1405%	\$ -	\$ -	0.1405%	\$ -	0.1405%	\$ -	
20			\$ -			\$ -			\$ -					
21			2015 EOY			2015 EOY			2015 EOY					
22			Accum. Depr: -			Accum. Depr: -			Accum. Depr: -					
23	Year		Total		Year	Total		Year	Total		Year	Total		
			Gross Plant	Accm. Deprec.	Net Plant	Gross Plant	Accm. Deprec.	Net Plant	Gross Plant	Accm. Deprec.	Net Plant	Gross Plant	Accm. Deprec.	Net Plant
24			13 Month Averages			13 Month Averages			13 Month Averages			13 Month Averages		
25	2010		\$ -	\$ -	\$ -	\$ -	\$ -	\$ -	\$ -	\$ -	\$ -	\$ -	\$ -	\$ -
26	2011		\$ -	\$ -	\$ -	\$ -	\$ -	\$ -	\$ -	\$ -	\$ -	\$ -	\$ -	\$ -
27	2012		\$ -	\$ -	\$ -	\$ -	\$ -	\$ -	\$ -	\$ -	\$ -	\$ -	\$ -	\$ -
28	2013		\$ -	\$ -	\$ -	\$ -	\$ -	\$ -	\$ -	\$ -	\$ -	\$ -	\$ -	\$ -
29	2014		\$ -	\$ -	\$ -	\$ -	\$ -	\$ -	\$ -	\$ -	\$ -	\$ -	\$ -	\$ -
30	2015		\$ -	\$ -	\$ -	\$ -	\$ -	\$ -	\$ -	\$ -	\$ -	\$ -	\$ -	\$ -
31	2016		\$ -	\$ -	\$ -	\$ -	\$ -	\$ -	\$ -	\$ -	\$ -	\$ -	\$ -	\$ -
32	2017		\$ -	\$ -	\$ -	\$ -	\$ -	\$ -	\$ -	\$ -	\$ -	\$ -	\$ -	\$ -
33	2018		\$ -	\$ -	\$ -	\$ -	\$ -	\$ -	\$ -	\$ -	\$ -	\$ -	\$ -	\$ -
34	2019		\$ -	\$ -	\$ -	\$ -	\$ -	\$ -	\$ -	\$ -	\$ -	\$ -	\$ -	\$ -
35	2020		\$ -	\$ -	\$ -	\$ -	\$ -	\$ -	\$ -	\$ -	\$ -	\$ -	\$ -	\$ -
36	2021		\$ -	\$ -	\$ -	\$ -	\$ -	\$ -	\$ -	\$ -	\$ -	\$ -	\$ -	\$ -
37	2022		\$ -	\$ -	\$ -	\$ -	\$ -	\$ -	\$ -	\$ -	\$ -	\$ -	\$ -	\$ -
38	2023		\$ -	\$ -	\$ -	\$ -	\$ -	\$ -	\$ -	\$ -	\$ -	\$ -	\$ -	\$ -
39	2024		\$ -	\$ -	\$ -	\$ -	\$ -	\$ -	\$ -	\$ -	\$ -	\$ -	\$ -	\$ -
40	2025		\$ -	\$ -	\$ -	\$ -	\$ -	\$ -	\$ -	\$ -	\$ -	\$ -	\$ -	\$ -
41	2026		\$ -	\$ -	\$ -	\$ -	\$ -	\$ -	\$ -	\$ -	\$ -	\$ -	\$ -	\$ -
42	2027		\$ -	\$ -	\$ -	\$ -	\$ -	\$ -	\$ -	\$ -	\$ -	\$ -	\$ -	\$ -
43	2028		\$ -	\$ -	\$ -	\$ -	\$ -	\$ -	\$ -	\$ -	\$ -	\$ -	\$ -	\$ -
44	2029		\$ -	\$ -	\$ -	\$ -	\$ -	\$ -	\$ -	\$ -	\$ -	\$ -	\$ -	\$ -
45	2030		\$ -	\$ -	\$ -	\$ -	\$ -	\$ -	\$ -	\$ -	\$ -	\$ -	\$ -	\$ -

- Notes:**
- (A) See WP A-5 (Act Depreciation Rate).
 - (B) This rate will reflect any future KCC approved depreciation rates.
 - (C) Projects constructed by SEPC on behalf of Third Parties that have been completed and whose costs are in the KCC Annual Report should be entered on this page. If a project is completed in phases over multiple years, that project should be entered in sheet P-4 until the entire project is completed and reported in the Annual Report.
 - (D) Third Party Projects with incentives granted by FERC should be included in Sheet A-9 as well as on this sheet.
 - (E) Accumulated Depreciation will be brought forward from the prior year for each project.

Sunflower Electric Power Corporation (SEPC)
Administrative & General Expense
For the 12 months ended - December 31, 2016

Line No.	Description	Source	Annual Expense	Allocation		Allocated to Transmission
				Factor	Rate	
1	Administrative & General Expense	Pg.36-1,L31, Col. b	\$ 14,742,006	WS	26.6584%	\$ 3,929,981
2	Less: General Advertising Costs		47,295	WS	26.6584%	12,608
3	Less: Regulatory Commission Expenses		101,633	WS	26.6584%	27,094
4	Less: Corporate Visibility Expenses		-	WS	26.6584%	-
5	Less: Misc Nuclear Expenses (included in Account 930.2)		-	WS	26.6584%	-
6	Less: Experimental & Gen. Research Exp.		-	WS	26.6584%	-
7	Less: Industry Association Dues		205,498	WS	26.6584%	54,782
8	Subtotal		\$ 14,387,580			\$ 3,835,497
9	Plus Safety Advertising		-	WS	26.6584%	\$ -
10	Plus Association Dues Directly Related to Transmission		-	DA	100.0000%	\$ -
11	Plus: General Advertising:					
12	Transmission Facilities Sitting	\$ -				
13	Transmission Vegetation Management	-				
14	Transmission Reliability	-				
15	Total Advertising for Transmission		\$ -	DA	100.0000%	\$ -
16	Plus: Transmission Specific Research & Experimental					
17	Project #1	\$ -				
18	Project #2	-				
19	Project #3	-				
20	Total Research & Experimental Expenses		\$ -	DA	100.0000%	\$ -
21	Plus Transmission Related Reg. Comm. Exp.					
22	Formula Rate	\$ -		DA	100.0000%	\$ -
23	Other-Specifically Assignable to Transmission	-		DA	100.0000%	-
24	KCC Assessment (Note F)	24,400		DA	100.0000%	24,400
25	Total Transmission Regulatory Expense		\$ 24,400			\$ 24,400
26	Plus: Corporate Visibility Expenses:					
27	Regulatory	\$ -				
28	Reporting	-				
29	Compliance	-				
30	Shareholder Communications	-				
31	Total Corporate Visibility Expenses		\$ -	WS	26.66%	\$ -
32	Total A&G Expense		\$ 14,411,980			\$ 3,859,896

None of the following expenses shall be recovered directly or indirectly through the formula rate:

- A. Industry association dues (e.g. , EEI, NRECA, KEC and EPRI).
- B. The following charges to Account 930.2: nuclear power research expenses, miscellaneous general expenses related to a Nuclear Generating Station; Nuclear Energy Institute fees, assessments and other costs; and any other nuclear-related expenses.
- C. Other experimental and general research expenditures (other than those related to transmission which shall be directly assigned to transmission).
- D. Expenses to Maintain Corporate Visibility (except such costs related to regulatory, reporting, compliance, and shareholder communications).
- E. All regulatory Commission expenses, except for FERC and/or KCC transmission-related dockets, which shall be directly assigned to transmission. Transmission-related dockets shall not include transmission-related rulemakings or notices of inquiry proceedings, except those related to siting or reliability.
- F. KCC assessment charge is calculated using the following formula: ((Net Intrastate Revenue Under KCC Jurisdiction divided by the total Revenue Under KCC Jurisdiction) multiplied by the total KCC Assessment charges for the year) Reference page 9A of Sunflower's KCC Annual Report

**Sunflower Electric Power Corporation (SEPC)
13 Month Average Balance and BOY-EOY Average Balances**

I. Plant Additions & Accumulated Depreciation Balances

Source: SEPC Financial Records. BOY and EOY totals may be found on Pgs. 10 & 11 of SEPC's KCC Annual Report

Line No.	Gross Plant (Note 1) (Note 2)														
	2015 Dec	2016 Jan	2016 Feb	2016 Mar	2016 Apr	2016 May	2016 Jun	2016 Jul	2016 Aug	2016 Sep	2016 Oct	2016 Nov	2016 Dec	13 Months Avg Balance	
1	Production-Steam	\$ 512,046,599	\$ 512,046,599	\$ 512,046,599	\$ 512,046,599	\$ 512,046,599	\$ 512,234,045	\$ 512,234,045	\$ 512,234,045	\$ 512,234,045	\$ 512,358,240	\$ 512,621,340	\$ 512,621,340	\$ 513,510,161	\$ 512,329,250
2	Production-Other	18,758,021	18,758,021	18,758,021	18,758,021	18,758,021	18,758,021	18,758,021	21,362,730	21,362,730	21,362,730	21,362,730	21,362,730	21,362,730	19,759,832
3	Trans.(Excl. Cap. Lease)	127,624,563	127,624,564	127,619,499	127,619,498	127,782,084	128,136,373	128,096,606	128,096,608	128,211,081	128,202,986	128,345,732	128,448,008	128,776,640	128,044,942
4	Trans. Capital Leases	19,864,916	19,769,888	19,674,861	19,579,834	19,716,331	19,389,780	19,294,753	19,199,725	19,104,698	19,009,671	18,914,644	18,819,617	18,724,590	19,312,562
5	Distribution	-	-	-	-	-	-	-	-	-	-	-	-	-	-
6	General Plant	46,749,838	46,749,838	46,876,626	47,062,896	47,094,003	47,258,463	47,235,380	47,365,319	47,442,439	47,533,321	47,754,946	47,805,323	49,055,534	47,383,379
7	Intangible & Other	-	-	-	-	-	-	-	-	-	-	-	-	-	-
8	Total	\$ 725,043,937	\$ 724,948,910	\$ 724,975,606	\$ 725,066,848	\$ 725,397,038	\$ 725,776,682	\$ 725,618,805	\$ 725,653,718	\$ 728,354,993	\$ 728,466,948	\$ 728,999,392	\$ 729,057,018	\$ 731,429,655	\$ 726,829,965
9	Transmission (Excludes Capital Leases) 12 month average December, 2015 to November, 2016														
10	Trans. Oper Leases	\$ 17,653,096	\$ 17,653,096	\$ 17,653,096	\$ 17,653,096	\$ 17,653,096	\$ 17,653,096	\$ 17,653,096	\$ 17,653,096	\$ 17,653,096	\$ 17,653,096	\$ 17,653,096	\$ 17,653,096	\$ 17,653,096	\$ 17,653,096

Source: SEPC Financial Records. BOY and EOY totals may be found on Pg. 38 of SEPC's KCC Annual Report

Line No.	Accumulated Depreciation and Amortization (Note 1) (Note 2)														
	2015 Dec	2016 Jan	2016 Feb	2016 Mar	2016 Apr	2016 May	2016 Jun	2016 Jul	2016 Aug	2016 Sep	2016 Oct	2016 Nov	2016 Dec	13 Months Avg Balance	
11	Production-Steam	\$ 345,966,895	\$ 346,112,999	\$ 346,745,159	\$ 347,377,318	\$ 348,009,478	\$ 348,642,460	\$ 349,274,946	\$ 349,904,762	\$ 350,537,248	\$ 351,170,383	\$ 351,804,460	\$ 352,437,620	\$ 353,044,761	\$ 349,309,884
12	Production-Other	13,890,868	14,393,638	14,410,353	14,427,069	14,443,784	14,460,499	14,477,215	14,493,930	14,524,537	14,544,726	14,564,914	14,585,102	14,593,309	14,446,919
13	Trans.(Excl. Cap. Lease)	80,377,565	80,556,909	80,731,009	80,882,535	81,064,283	81,245,321	81,360,340	81,540,649	81,720,136	81,891,146	82,047,395	82,207,893	82,362,744	81,383,687
14	Trans. Capital Leases	-	-	-	-	-	-	-	-	-	-	-	-	-	-
15	Distribution	-	-	-	-	-	-	-	-	-	-	-	-	-	-
16	General Plant	22,797,370	22,987,073	23,144,070	23,313,779	23,484,305	23,674,248	23,803,533	23,994,309	24,185,500	24,369,057	24,512,809	24,612,813	24,837,200	23,824,313
17	Intangible & Other	-	-	-	-	-	-	-	-	-	-	-	-	-	-
18	Total	463,032,698	464,050,619	465,030,591	466,000,701	467,001,850	468,022,528	468,916,034	469,933,650	470,967,421	471,975,312	472,929,578	473,843,428	474,838,014	468,964,802
19	Trans. Oper Leases	\$ 872,671	\$ 893,082	\$ 913,493	\$ 933,904	\$ 954,315	\$ 974,726	\$ 995,137	\$ 1,016,937	\$ 1,038,737	\$ 1,060,537	\$ 1,082,336	\$ 1,104,136	\$ 1,125,936	\$ 997,381

Net Plant (Gross Plant less Accumulated Depreciation and Amortization)

Line No.	Net Plant (Gross Plant less Accumulated Depreciation and Amortization)														
	2015 Dec	2016 Jan	2016 Feb	2016 Mar	2016 Apr	2016 May	2016 Jun	2016 Jul	2016 Aug	2016 Sep	2016 Oct	2016 Nov	2016 Dec	13 Months Avg Balance	
20	Production-Steam	\$ 166,079,704	\$ 165,933,600	\$ 165,301,440	\$ 164,669,281	\$ 164,037,121	\$ 163,591,585	\$ 162,959,099	\$ 162,329,283	\$ 161,696,797	\$ 161,187,857	\$ 160,816,880	\$ 160,183,720	\$ 160,465,400	\$ 163,019,367
21	Production-Other	4,867,153	4,364,383	4,347,668	4,330,952	4,314,237	4,297,522	4,280,806	4,264,091	6,838,193	6,818,004	6,797,816	6,777,628	6,769,421	5,312,913
22	Trans.(Excl. Cap. Lease)	47,246,998	47,067,655	46,888,490	46,736,963	46,717,801	46,891,052	46,736,266	46,555,959	46,490,945	46,311,840	46,298,337	46,240,115	46,413,896	46,661,255
23	Trans. Capital Leases	19,864,916	19,769,888	19,674,861	19,579,834	19,716,331	19,389,780	19,294,753	19,199,725	19,104,698	19,009,671	18,914,644	18,819,617	18,724,590	19,312,562
24	Distribution	-	-	-	-	-	-	-	-	-	-	-	-	-	-
25	General Plant	23,952,468	23,762,765	23,732,556	23,749,117	23,609,698	23,584,215	23,431,847	23,371,010	23,256,939	23,164,264	23,242,137	23,192,510	24,218,334	23,559,066
26	Intangible & Other	-	-	-	-	-	-	-	-	-	-	-	-	-	-
27	Total	\$ 262,011,239	\$ 260,898,291	\$ 259,945,015	\$ 259,066,147	\$ 258,395,188	\$ 257,754,154	\$ 256,702,771	\$ 255,720,068	\$ 257,387,572	\$ 256,491,636	\$ 256,069,814	\$ 255,213,590	\$ 256,591,641	\$ 257,865,164
28	Trans. Oper Leases	\$ 16,780,425	\$ 16,760,014	\$ 16,739,603	\$ 16,719,192	\$ 16,698,781	\$ 16,678,370	\$ 16,657,959	\$ 16,636,159	\$ 16,614,359	\$ 16,592,559	\$ 16,570,760	\$ 16,548,960	\$ 16,527,160	\$ 16,655,715

Construction Work in Progress (Note 1)

Line No.	Construction Work in Progress (Note 1)														
	2015 Dec	2016 Jan	2016 Feb	2016 Mar	2016 Apr	2016 May	2016 Jun	2016 Jul	2016 Aug	2016 Sep	2016 Oct	2016 Nov	2016 Dec	13 Months Avg Balance	
29	Production	\$ 674,346	\$ 752,395	\$ 860,674	\$ 932,988	\$ 772,242	\$ 813,119	\$ 884,492	\$ 806,393	\$ 815,630	\$ 1,016,963	\$ 1,055,174	\$ 1,686,902	\$ 1,023,846	\$ 930,397
30	Transmission	438,998	427,636	511,159	424,407	669,837	1,039,395	1,038,889	1,216,381	1,582,565	1,810,263	2,402,707	2,388,268	4,066,531	1,385,926
31	Distribution	-	-	-	-	-	-	-	-	-	-	-	-	-	-
32	General Plant	401,349	417,765	468,981	1,000,842	1,048,000	1,143,165	1,444,303	1,561,321	1,656,651	1,648,744	1,849,432	1,942,318	625,946	1,169,909
33	Total	\$ 1,514,693	\$ 1,597,796	\$ 1,840,815	\$ 2,358,236	\$ 2,490,079	\$ 2,995,679	\$ 3,367,684	\$ 3,584,095	\$ 4,054,846	\$ 4,475,969	\$ 5,307,314	\$ 6,017,488	\$ 5,716,324	\$ 3,486,232

- Notes:** 1. When calculating the "Actual Gross Revenue Requirement", use the actual 13 month account balances for the year being trued-up.
2. For Capital Leases, the Plant-in-Service values are reduced as principal is paid off. No depreciation/amortization expense is recorded as it is included in the lease payment; and no reserves for depreciation are accumulated.

**Sunflower Electric Power Corporation (SEPC)
13 Month Average Balance and BOY-EOY Average Balances**

II. Adjustments to Rate Base

	EOY Balance 2015	EOY Balance 2016	Average Balance	100% Non-Trans Related	100% Trans. Related	Plant Related	Labor Related
34 Reserve Funds (Non-Escrowed) (Note A)							
35 Account 228.2 -Reserve for Inj. & Damages	\$ -	\$ -	\$ -	\$ -	\$ -	\$ -	\$ -
36	\$ -	\$ -	\$ -	-	-	-	-
37 Total	\$ -	\$ -	\$ -	\$ -	\$ -	\$ -	\$ -
38							
39							26.658%
40						23.373%	
41					100.000%		
42				\$ -	\$ -	\$ -	\$ -

Note: Each non-escrowed reserve fund will be allocated based on Non-transmission, 100% Transmission, Plant Allocator, or Wages & Salary Allocator, as appropriate.

	2015 Dec	2016 Jan	2016 Feb	2016 Mar	2016 Apr	2016 May	2016 Jun	2016 Jul	2016 Aug	2016 Sep	2016 Oct	2016 Nov	2016 Dec	13 Months Avg Balance
43 Unamortized Abandoned Trans. Pft.														
44 Account 182.1	\$ -	\$ -	\$ -	\$ -	\$ -	\$ -	\$ -	\$ -	\$ -	\$ -	\$ -	\$ -	\$ -	\$ -
45														
46 CWIP Regulatory Liability for Transmission														
47 Account 254	\$ -	\$ -	\$ -	\$ -	\$ -	\$ -	\$ -	\$ -	\$ -	\$ -	\$ -	\$ -	\$ -	\$ -
48														
49 Land Held for Future Use														
50 Trans. Land	\$ -	\$ -	\$ -	\$ -	\$ -	\$ -	\$ -	\$ -	\$ -	\$ -	\$ -	\$ -	\$ -	\$ -

III. Working Capital -Material & Supplies, Stores Expense and Prepayments

Source: SEPC's Annual KCC Report and Corporate Records

	EOY Balance 2015	EOY Balance 2016	Average Balance
51 Material & Supplies	Pg. 16, Col. b	Pg. 16, Col. c	
52 Fuel Stocks	\$ 6,319,231	\$ 3,033,586	\$ 4,676,409
53 Production O&M	7,874,464	7,960,459	7,917,462
54 Transmission O&M	1,368,041	1,705,851	1,536,946
55 Distribution O&M	-	-	-
56 Prod. Construction	-	-	-
57 Trans. Construction	-	-	-
58 Dist. Construction	-	-	-
59 Total Material & Supplies	\$ 15,561,736	\$ 12,699,896	\$ 14,130,816

	EOY Balance 2015	EOY Balance 2016	Average Balance
60 Stores Expense	Pg.16, L8,Col.b	Pg.16, L8,Col.c	
61 Total Stores Expense	\$ -	\$ -	\$ -

	EOY Balance 2015	EOY Balance 2016	Average Balance
62 Prepayments			
63 Prepayments	\$ 1,199,725	\$ 1,263,401	\$ 1,231,563
64			
65 Total Prepayments	\$ 1,199,725	\$ 1,263,401	\$ 1,231,563

**Sunflower Electric Power Corporation (SEPC)
True-up Adjustment and Timeline**

Timeline

<u>Step</u>	<u>Month</u>	<u>Year</u>	<u>Action</u>	
1		Year 0	2017	SEPC populates the formula rate using projected costs for Year 1
2		Year 0	2017	Post results of Step 1
3	Jan	Year 1	2018	Results of Step 2 go into effect.
4	Sept	Year 1	2018	SEPC populates the formula rate using projected costs for Year 2
5	Sept	Year 1	2018	Post results of Step 4
6	Jan	Year 2	2019	Results of Step 5 go into effect.
7	Jun	Year 2	2019	SEPC populates the formula rate using actual costs for Year 1
8	Jun	Year 2	2019	Calculate the difference between the formula rate calculated in Step 7 and Step 1
9	Jun	Year 2	2019	Post results from Step 7 and Step 8
10	Sept	Year 2	2019	SEPC populates the formula rate using projected costs for Year 3, including true-up adjustment for Year 1
11	Sept	Year 2	2019	Post results of Step 10
12	Jan	Year 3	2020	Results of Step 11 go into effect.

Reconciliation details for 2016

	<u>Base Plan</u>	<u>Balance Portfolio</u>	<u>ITP / Priority Project 1</u>	<u>ITP / Priority Project 2</u>	<u>Sponsored</u>	<u>Third Party</u>	<u>Zonal Rev Req</u>	<u>Total Rev. Req.</u>
	(1)	(2)	(3)	(4)	(5)	(6)	(7)	(8)
1 Actual Revenue Requirements from Step 7	\$ 4,043,162	\$ -	\$ -	\$ -	\$ -	\$ -	\$ 14,581,997	\$ 18,625,158
2 Projected Revenue Requirements from Step 1 (Note C)	4,820,227	-	-	-	-	-	16,428,092	21,248,319
3 True-up Amount (before interest)	\$ (777,065)	\$ -	\$ -	\$ -	\$ -	\$ -	\$ (1,846,095)	\$ (2,623,161)

Sunflower Electric Power Corporation (SEPC) True-up Adjustment and Timeline

- 4 Jun Year 2 Post results from Step 7 and Step 8
- 5 Sept Year 2 SEPC populates the formula rate using projected costs for Year 3, including true-up adjustment for Year 1

Interest Calculation

<u>Short term Interest Rate (Notes A and F)</u>		Avg. Ann. Short Term Int.
6	Other Interest Exp.(Notes, p.117) (Note A)	-
7	Notes Payable (Acct. 231-daily balances (Note A)	-
8	No. of Months	12
9	Annual Short-term Int Rate L6 / L7	0.0000%

<u>FERC Quarterly Interest Rate</u>		
10	Qtr 3 (Previous Year)	3.5000%
11	Qtr 4 (Previous Year)	3.5000%
12	Qtr 1 (Current Year)	3.5000%
13	Qtr 2 (Current Year)	3.7100%
14	Average of the last 4 quarters Sum(L10:L13) / 4	3.5525%

15 Interest Rate Used for True-up adjustment (Note B) 3.5525% 3.5525% 3.5525% 3.5525% 3.5525% 3.5525% 3.5525%

	<u>Base Plan</u>	<u>Balance Portfolio</u>	<u>ITP / Priority Project 1</u>	<u>ITP / Priority Project 2</u>	<u>Sponsored</u>	<u>Third Party</u>	<u>Zonal Rev Req</u>	<u>Total Rev. Req.</u>
	(1)	(2)	(3)	(4)	(5)	(6)	(7)	(8)
16 True-Up Amount (line 8c) (Note D)	\$ (777,065)	\$ -	\$ -	\$ -	\$ -	\$ -	\$ (1,846,095)	\$ (2,623,160)
17 Interest on True-up Amount ([Avg. Interest Rate / 12 months]*24 mo.)	(55,210)	-	-	-	-	-	(131,165)	(186,376)
18 True-up Adjustment (Note E)	\$ (832,275)	\$ -	\$ -	\$ -	\$ -	\$ -	\$ (1,977,260)	\$ (2,809,536)

Notes:

- A The short term interest rate is based on a 12 month rate ending June of the year in which the Annual Update is prepared, with denominator calculated using daily balances and the numerator based on Form 3Q.
- B Use the lower of L9 and L14 if the True-up Amount (L16) is greater than or equal to zero. Use L14 if the True-up amount (L16) is less than zero.
- C Enter the Projected Revenue Requirement for the Actual period without a true-up adjustment plus any adjustments, either positive or negative, resulting from corrections of prior years. For 2013 and 2014, set this equal to L2
- D If the annual update is for a partial year, not 12 months, then the amount on L16 shall be prorated to represent the number of months in the partial year.
- E If the annual update is for a partial year, monthly interest will be multiplied by 18 plus one-half of the months in the partial year.
- F The numerator and denominator of the short-term interest rate calculation will reflect consistent debt components.

Sunflower Electric Power Corporation (SEPC)
RTO Project Summary - Summary of RTO Directed Projects
Revenue Requirement of SPP Projects included in SEPC's Projected Revenue Requirements (Note D):
For the 12 months ended - December 31, 2018

<u>Line</u>	<u>Description</u>	<u>Source</u>	<u>Total System</u>	<u>Development of Applicable Carrying Charges</u>						
				<u>Base Plan Projects</u>	<u>Balanced Portfolio</u>	<u>ITP Priority #1 Projects</u>	<u>ITP Priority #2 Projects</u>	<u>Sponsored Projects</u>	<u>Third Party Projects</u>	
1	Transmission Gross Plant in Service (excludes leases)	Projected Gross Rev Req L3 - L4	\$ 154,212,107							
2	Transmission Net Plant in Service (excludes leases)	Projected Gross Rev Req L21 - L22	\$ 70,613,653							
3	Plus: Net Plant Attributable to Capital Lease Projects	P-1 (Trans Plant), L187	\$ 16,914,876							
4	Plus: Net Plant Attributable to Operating Lease Projects	P-1 (Trans Plant), L218	\$ 41,751,681							
5	Net Plant Excluded for O&M, Other Taxes and General Plant	Note A	-							
6	Adjusted Net Plant for O&M and Other Taxes	L2 + L3 + L4 - L5	\$ 129,280,210							
7	Transmission O&M (includes allocation of A&G)	Projected Gross Rev Req L65 - L64	\$ 13,862,139							
8	Percent of Net Plant	L7 / L6	10.72%							
9	Other Taxes	Projected Gross Rev Req L85	\$ 101							
10	Percent of Net Plant	L9 / L6	0.00%							
11	General & Intangible Plant Allocation									
12	Depreciation	Projected Gross Rev Req L71 + L72	\$ 634,533							
13	Return	Projected Gross Rev Req ((L24 + L25) / L26) * L88	455,902							
14	Total	L10 + L11	\$ 1,090,435							
15	Percent of Net Plant	L12 / L6	0.84%							
16	Return (New Facilities)		8.32%							
		Actual Gross Rev Req L173 * L150								
17	True-Up Adjustment	TU (True-Up), Pg 1, L18		\$ (832,275)	\$ -	\$ -	\$ -	\$ -	\$ -	\$ -
18	As a Percent of Actual Projects Revenue	L17 / Line T1, Col. o below		-25.84%	0.00%	0.00%	0.00%	0.00%	0.00%	0.00%

Note (A): For some Special Projects, constructed on behalf of others, Sunflower may contract with the other party to operate and maintain the subject facilities. Under such circumstances, the O&M and associated labor expenses are not recorded on Sunflower's books. No such projects are projected through 2014.

Sunflower Electric Power Corporation (SEPC)
RTO Project Summary - Summary of RTO Directed Projects
Revenue Requirement of SPP Projects included in SEPC's Projected Revenue Requirements (Note D):
For the 12 months ended - December 31, 2018

Base Plan Projects (Sunflower Owned)

Note A: All line references are to page 1 of this worksheet.

Note B: To be completed with any BPP project approved by the Southwest Power Pool.

Note C: This tab shows the amount in column s that SPP is required to recover for each BPP project.

Line	Project ID	Project Description	In Service Date	(a)	(b)	(c)	(d)	(e)	(f)	(g)	(h)	(i)	(j)
				Plant in Service @ 12/16 (WP A-7)	Actual Accum Depr. @ 12/16 (WP A-7)	Actual Net Plant @ 12/16 (a - b)	Depreciation Rate (WP A-5)	Projected Added Accum. Depr. 1.5 * (a * d)	Projected Net Plant (a - b - e)	O&M Expenses (f * L8)	Other Taxes (f * L10)	Non-Incentive Return (L16)	General Plant Allocation (f * L15)
19	Actual Sunflower Owned Base Plan Projects (Inputs from Worksheet A-7)												
20	256	Johnson to Pioneer 115kV Line	AUG-10	\$ 3,117,703	\$ 331,210	\$ 2,786,493	1.69%	\$ 78,855	\$ 2,707,638	\$ 290,328	\$ 2	8.32%	\$ 22,838
21	30234	Johnson Corner Capacitor Bank #1	MAY-12	\$ 363,269	\$ 28,222	\$ 335,047	1.69%	\$ 9,188	\$ 325,859	\$ 34,940	\$ -	8.32%	\$ 2,749
22	30235	Johnson Corner Capacitor Bank #2	MAY-12	\$ 263,647	\$ 20,367	\$ 243,280	1.69%	\$ 6,668	\$ 236,612	\$ 25,371	\$ -	8.32%	\$ 1,996
23													
24	Total of Actual Base Plan Projects			\$ 3,744,619	\$ 379,799	\$ 3,364,820		\$ 94,711	\$ 3,270,109	\$ 350,639	\$ 2		\$ 27,582
25													
26													
27													
28	Project ID	Project Description	In Service Date	13 mo. Avg. Plant in Service 2018 (WP P-4)				13 mo. Avg. Projected Accum Depr (WP P-4)	Projected Net Plant (a - e)	O&M Expenses (f * L8)	Other Taxes (f * L10)	Non-Incentive Return (L16)	General Plant Allocation (f * L15)
29													
30	Projected Sunflower Owned Base Plan Projects (Inputs from Worksheet P-4)												
31	30916	Buckner - Spearville 345 kV Ckt 1 Terminal Upgrade	DEC-17	\$ 3,892,077				\$ 32,814	\$ 3,859,263	\$ 413,812	\$ 3	8.32%	\$ 32,552
32	30912	Walkemeyer Tap - Walkemeyer 345/115 kV	JUN-18	\$ 9,763,391				\$ 41,157	\$ 9,722,234	\$ 1,042,472	\$ 8	8.32%	\$ 82,004
33	30917	Ellsworth 115 kV Cap Bank	JUN-18	\$ 1,606,444				\$ 6,772	\$ 1,599,672	\$ 171,526	\$ 1	8.32%	\$ 13,493
34	30952	Ingalls 115 kV Cap Bank	APR-18	\$ 3,823,493				\$ 21,489	\$ 3,802,004	\$ 407,672	\$ 3	8.32%	\$ 32,069
35	0	0		\$ -				\$ -	\$ -	\$ -	\$ -	8.32%	\$ -
36	0	0		\$ -				\$ -	\$ -	\$ -	\$ -	8.32%	\$ -
37													
38	Total of Projected Sunflower Owned Base Plan Projects			\$ 19,085,404				\$ 102,232	\$ 18,983,173	\$ 2,035,482	\$ 15		\$ 160,117
39													
40	Total Sunflower Owned Base Plan Projects (L27 + L38)			\$ 22,830,023				\$ 196,943	\$ 22,253,282	\$ 2,386,121	\$ 17		\$ 187,699

Sunflower Electric Power Corporation (SEPC)
RTO Project Summary - Summary of RTO Directed Projects
Revenue Requirement of SPP Projects included in SEPC's Projected Revenue Requirements (Note D):
For the 12 months ended - December 31, 2018

Base Plan Projects (Sunflower Owned) (continued)

<u>Line</u>	<u>Project ID</u>	<u>Project Description</u>	(k) <u>Return Adder</u> (A-9 as applicable)	(l)	(m) <u>Total Return</u> (f*i)+(f*k)	(n) <u>Projected Depr Expense</u> (a * d)	(o) <u>Rev. Req w/o True-up</u> (g+h+j+m+n)	(p) <u>True-up Adjustment</u> (o * L18)	(q) <u>Adj. Revenue Requirement</u> (o + p)	(r) <u>Eff. Carrying Charge Rate (D)</u> (q / f)
19	Actual Projects (Inputs from Worksheet A-7)									
20	256	Johnson to Pioneer 115kV Line	0.00%		\$ 225,397	\$ 52,570	\$ 591,135	\$ (152,770)	\$ 438,365	21.83%
21	30234	Johnson Corner Capacitor Bank #1	0.00%		\$ 27,126	\$ 6,125	\$ 70,940	\$ (18,333)	\$ 52,607	21.77%
22	30235	Johnson Corner Capacitor Bank #2	0.00%		\$ 19,697	\$ 4,446	\$ 51,509	\$ (13,312)	\$ 38,197	21.77%
23										
24	Total of Actual Base Plan Projects				\$ 272,220	\$ 63,141	\$ 713,584	\$ (184,415)	\$ 529,169	21.82%
25										
26										
27										
28	<u>Project ID</u>	<u>Project Description</u>	<u>Weighted Return Adder</u>		<u>Total Return</u>	<u>Projected Depr Expense</u>	<u>Rev. Req w/o True-up</u>	<u>True-up Adjustment</u>	<u>Adj. Revenue Requirement</u>	<u>Eff. Carrying Charge Rate (D)</u>
29			(P-1 as applicable)		(f*i)+(f*k)	(P-4)	(g+h+j+m+n)	N.A.	(o + p)	(q / f)
30	Projected projects (Inputs from Worksheet P-4)									
31	30916	Buckner - Spearville 345 kV Ckt 1 Terminal Upgrade	0.00%		\$ 321,263	\$ 65,628	\$ 833,258		\$ 833,258	21.59%
32	30912	Walkemeyer Tap - Walkemeyer 345/115 kV	0.00%		\$ 809,325	\$ 152,868	\$ 2,086,677		\$ 2,086,677	21.46%
33	30917	Ellsworth 115 kV Cap Bank	0.00%		\$ 133,164	\$ 25,152	\$ 343,336		\$ 343,336	21.46%
34	30952	Ingalls 115 kV Cap Bank	0.00%		\$ 316,497	\$ 62,080	\$ 818,321		\$ 818,321	21.52%
35	0	0	0.00%		\$ -	\$ -	\$ -		\$ -	
36			0.00%		\$ -	\$ -	\$ -		\$ -	
37										
38	Total of Projected Sunflower Owned Base Plan Projects				\$ 1,580,249	\$ 305,728	\$ 4,081,591		\$ 4,081,591	21.50%
39										
40	Total Sunflower Owned Base Plan Projects (L27 + L38)				\$ 1,852,469	\$ 368,869	\$ 4,795,175		\$ 4,610,760	21.55%

(D) Effective carrying charge rate as a percent of net plant before true up is applied.

Sunflower Electric Power Corporation (SEPC)
RTO Project Summary - Summary of RTO Directed Projects
Revenue Requirement of SPP Projects included in SEPC's Projected Revenue Requirements (Note D):
For the 12 months ended - December 31, 2018

Base Plan Projects (Capital Leases)

Note A: All line references are to page 1 of this worksheet.

Note B: To be completed with any BPP project approved by the Southwest Power Pool.

Note C: This tab shows the amount in column s that SPP is required to recover for each BPP project.

Line	Project ID	Project Description	In Service Date	(a) Plant in Service @ 12/16 (WP A-7)	(b) Actual Accum Amor. @ 12/16 (WP A-7)	(c) Actual Net Plant @ 12/16 (a - b)	(d)	(e) Projected Accum. Amort. (13 mo. Avg for 2018)	(f) Projected Net Plant (a - e)	(g) O&M Expenses (f * L8)	(h) Other Taxes (f * L10)	(i)	(j) General Plant Allocation (f * L15)
41	Actual Capital Lease Base Plan Projects (Inputs from Worksheet A-7)												
42	899	Holcomb to Fletcher 115kV Line (Wheatland)	NOV-13	\$ 4,091,866	\$ 1,007,078	\$ 3,084,788		\$ 1,569,274	\$ 2,522,592	\$ 270,486	\$ 2		\$ 21,277
43	0	0		\$ -	\$ -	\$ -		\$ -	\$ -	\$ -	\$ -		\$ -
44	0	0		\$ -	\$ -	\$ -		\$ -	\$ -	\$ -	\$ -		\$ -
45													
46	Total of Capital Lease Actual Base Plan Projects			\$ 4,091,866	\$ 1,007,078	\$ 3,084,788		\$ 1,569,274	\$ 2,522,592	\$ 270,486	\$ 2		\$ 21,277
47													
48													
49													
50	Project ID	Project Description	In Service Date	13 mo. Avg. Plant in Service 2018 (WP P-4)			(d)	13 mo. Avg. Projected Accum. Amort. (WP P-4)	Projected Net Plant (a - e)	O&M Expenses (f * L8)	Other Taxes (f * L10)	(i)	General Plant Allocation (f * L15)
51													
52	Projected Capital Lease Base Plan Projects (Inputs from Worksheet P-4)												
53	0	0		\$ -			\$ -	\$ -	\$ -	\$ -			\$ -
54	0	0		\$ -			\$ -	\$ -	\$ -	\$ -			\$ -
55	0	0		\$ -			\$ -	\$ -	\$ -	\$ -			\$ -
56													
57	Total of Projected Capital Lease Base Plan Projects			\$ -				\$ -	\$ -	\$ -	\$ -		\$ -
58													
59	Total Capital Lease Base Plan Projects (L49 + L57)			\$ 4,091,866				\$ 1,569,274	\$ 2,522,592	\$ 270,486	\$ 2		\$ 21,277

Sunflower Electric Power Corporation (SEPC)
RTO Project Summary - Summary of RTO Directed Projects
Revenue Requirement of SPP Projects included in SEPC's Projected Revenue Requirements (Note D):
For the 12 months ended - December 31, 2018

Base Plan Projects (Capital Leases) (continued)

<u>Line</u>	<u>Project ID</u>	<u>Project Description</u>	(k)	(l)	(m)	(n)	(o)	(p)	(q)	(r)
					2018 Lease Payments		Rev. Req w/o True-up	True-up Adjustment	Adj. Revenue Requirement	Eff. Carrying Charge Rate (D)
							(g+h+j+m)	(o * L18)	(o + p)	(q / f)
41	Actual Projects (Inputs from Worksheet A-7)									
42	899	Holcomb to Fletcher 115kV Line (Wheatland)			\$ 586,636		\$ 878,401	\$ (227,010)	\$ 651,391	34.82%
43	0	0			\$ -		\$ -	\$ -	\$ -	
44	0	0			\$ -		\$ -	\$ -	\$ -	
45										
46	Total of Capital Lease Actual Base Plan Projects				\$ 586,636		\$ 878,401	\$ (227,010)	\$ 651,391	34.82%
47										
48										
49										
50	<u>Project ID</u>	<u>Project Description</u>			2018 Lease Payments		Rev. Req w/o True-up	True-up Adjustment	Adj. Revenue Requirement	Eff. Carrying Charge Rate (D)
51					(P-4)		(g+h+j+m)	N.A.	(o + p)	(q / f)
52	Projected projects (Inputs from Worksheet P-4)									
53	0	0			\$ -		\$ -		\$ -	
54	0	0			\$ -		\$ -		\$ -	
55	0	0			\$ -		\$ -		\$ -	
56										
57	Total of Projected Capital Lease Base Plan Projects				\$ -		\$ -		\$ -	
58										
59	Total Capital Lease Base Plan Projects (L49 + L57)				\$ 586,636		\$ 878,401		\$ 651,391	34.82%

(D) Effective carrying charge rate as a percent of net plant before true up is applied.

Sunflower Electric Power Corporation (SEPC)
RTO Project Summary - Summary of RTO Directed Projects
Revenue Requirement of SPP Projects included in SEPC's Projected Revenue Requirements (Note D):
For the 12 months ended - December 31, 2018

Base Plan Projects (Operating Leases)

Note A: All line references are to page 1 of this worksheet.

Note B: To be completed with any BPP project approved by the Southwest Power Pool.

Note C: This tab shows the amount in column s that SPP is required to recover for each BPP project.

Line	Project ID	Project Description	In Service Date	(a) Plant in Service @ 12/16 (WP A-7)	(b) Actual Accum Amor.@ 12/16 (WP A-7)	(c) Actual Net Plant @ 12/16 (a - b)	(d)	(e) Projected Accum. Amort. (13 mo. Avg for)	(f) Projected Net Plant (a - e)	(g) O&M Expenses (f * L8)	(h) Other Taxes (f * L10)	(i)	(j) General Plant Allocation (f * L15)
60	Actual Operating Lease Base Plan Projects (Inputs from Worksheet A-7)												
61	166	Holcomb to Plymell 115kV (MKEC)	JUN-12	\$ 3,400,999	\$ 197,147	\$ 3,203,852		\$ 276,319	\$ 3,124,680	\$ 335,045	\$ 2		\$ 26,356
62	367	Plymell to Pioneer Tap 115kV (MKEC)	JUN-12	\$ 4,322,255	\$ 250,545	\$ 4,071,710		\$ 351,168	\$ 3,971,087	\$ 425,802	\$ 3		\$ 33,495
63	0	0		\$ -	\$ -	\$ -		\$ -	\$ -	\$ -	\$ -		\$ -
64													
65	Total of Operating Lease Actual Base Plan Projects			\$ 7,723,254	\$ 447,692	\$ 7,275,562		\$ 627,487	\$ 7,095,767	\$ 760,847	\$ 5		\$ 59,850
66													
67													
68													
69	<u>Project ID</u>	<u>Project Description</u>	<u>In Service Date</u>	<u>13 mo. Avg. Plant in Service 2018</u> (WP P-4)				<u>13 mo. Avg. Projected Accum Depr</u> (WP P-4)	<u>Projected Net Plant</u> (a - e)	<u>O&M Expenses</u> (f * L8)	<u>Other Taxes</u> (f * L10)		<u>General Plant Allocation</u> (f * L15)
70													
71	Projected Operating Lease Base Plan Projects (Inputs from Worksheet P-4)												
72	30427	Mingo Transformer/Terminal Upgrades	Jan-17	\$ 12,929,229			\$ 17,256	\$ 12,911,973	\$ 1,384,493	\$ 10			\$ 108,908
73	0	0		\$ -			\$ -	\$ -	\$ -	\$ -			\$ -
74	0	0		\$ -			\$ -	\$ -	\$ -	\$ -			\$ -
75													
76	Total of Operating Lease Projected Base Plan Projects			\$ 12,929,229			\$ 17,256	\$ 12,911,973	\$ 1,384,493	\$ 10			\$ 108,908
77													
78	Total Operating Lease Base Plan Projects (L68 + L76)			\$ 20,652,483			\$ 644,743	\$ 20,007,740	\$ 2,145,340	\$ 15			\$ 168,759

Sunflower Electric Power Corporation (SEPC)
RTO Project Summary - Summary of RTO Directed Projects
Revenue Requirement of SPP Projects included in SEPC's Projected Revenue Requirements (Note D):
For the 12 months ended - December 31, 2018

Base Plan Projects (Operating Leases) (continued)

<u>Line</u>	<u>Project ID</u>	<u>Project Description</u>	(k)	(l)	(m)	(n)	(o)	(p)	(q)	(r)
					2018 Lease Payments		Rev. Req w/o True-up	True-up Adjustment	Adj. Revenue Requirement	Eff. Carrying Charge Rate (D)
							(g+h+j+m)	(o * L18)	(o + p)	(q / f)
60	Actual Projects (Inputs from Worksheet A-7)									
61	166	Holcomb to Plymell 115kV (MKEC)			\$ 355,700		\$ 717,103	\$ (185,325)	\$ 531,778	22.95%
62	367	Plymell to Pioneer Tap 115kV (MKEC)			\$ 452,047		\$ 911,347	\$ (235,525)	\$ 675,822	22.95%
63	0	0			\$ -		\$ -	\$ -	\$ -	
64										
65	Total of Operating Lease Actual Base Plan Projects				\$ 807,747		\$ 1,628,449	\$ (420,850)	\$ 1,207,599	22.95%
66										
67										
68										
69	<u>Project ID</u>	<u>Project Description</u>			2018 Lease Payments		Rev. Req w/o True-up	True-up Adjustment	Adj. Revenue Requirement	Eff. Carrying Charge Rate (D)
70					(P-4)		(g+h+j+m)	N.A.	(o + p)	(q / f)
71	Projected projects (Inputs from Worksheet P-4)									
72	30427	Mingo Transformer/Terminal Upgrades			\$ 1,352,222		\$ 2,845,633		\$ 2,845,633	22.04%
73	0	0			\$ -		\$ -		\$ -	
74					\$ -		\$ -		\$ -	
75										
76	Total of Operating Lease Projected Base Plan Projects				\$ 1,352,222		\$ 2,845,633		\$ 2,845,633	22.04%
77										
78	Total Operating Lease Base Plan Projects (L68 + L76)				\$ 2,159,969		\$ 4,474,083		\$ 4,053,233	22.36%

(D) Effective carrying charge rate as a percent of net plant before true up is applied.

**Sunflower Electric Power Corporation (SEPC)
RTO Project Summary - Summary of RTO Directed Projects
Revenue Requirement of SPP Projects included in SEPC's Projected Revenue Requirements (Note D):
For the 12 months ended - December 31, 2018**

Balanced Portfolio Projects

Note A: All line references are to page 1 of this worksheet.

Note B: To be completed with any BPP project approved by the Southwest Power Pool.

Note C: This tab shows the amount in column s that SPP is required to recover for each BPP project.

Line	Project ID	Project Description	In Service Date	(a)	(b)	(c)	(d)	(e)	(f)	(g)	(h)	(i)	(j)
				Plant in Service @ 12/16 (WP A-7)	Accum Depr. @ 12/16 (WP A-7)	Actual Net Plant @ 12/16 (a - b)	Depreciation Rate (WP A-5)	Proj. Additional Accum Depr 1.5 * (a * d)	Projected Net Plant (a - b - e)	O&M Expenses (f * L8)	Other Taxes (f * L10)	Non-Incentive Return (L16)	General Plant Allocation (f * L15)
79	Actual Balanced Portfolio Projects (Inputs from Worksheet A-7)												
80	0	0		\$ -	\$ -	\$ -	1.69%	\$ -	\$ -	\$ -	\$ -	8.32%	\$ -
81	0	0		\$ -	\$ -	\$ -	1.69%	\$ -	\$ -	\$ -	\$ -	8.32%	\$ -
82	0	0		\$ -	\$ -	\$ -	1.69%	\$ -	\$ -	\$ -	\$ -	8.32%	\$ -
83													
84	Total of Actual Balanced Portfolio Projects			\$ -	\$ -	\$ -		\$ -	\$ -	\$ -	\$ -		\$ -
85													
86													
87													
88	<u>Project ID</u>	<u>Project Description</u>	<u>In Service Date</u>	13 mo. Avg. Plant in Service 2018				13 mo. Avg. Projected Accum Depr	Projected Net Plant	O&M Expenses	Other Taxes	Non-Incentive Return	General Plant Allocation
89				(WP P-4)				(WP P-4)	(a - e)	(f * L8)	(f * L10)	(L16)	(f * L15)
90	Projected Balanced Portfolio Projects (Input from Worksheet P-4)												
91	0	Description		\$ -				\$ -	\$ -	\$ -	\$ -	8.32%	\$ -
92	0	Description		\$ -				\$ -	\$ -	\$ -	\$ -	8.32%	\$ -
93	0	Description		\$ -				\$ -	\$ -	\$ -	\$ -	8.32%	\$ -
94													
95	Total of Projected Balanced Portfolio Projects			\$ -				\$ -	\$ -	\$ -	\$ -		\$ -
96													
97	Total Balanced Portfolio Projects (L84 + L95)			\$ -				\$ -	\$ -	\$ -	\$ -		\$ -

Sunflower Electric Power Corporation (SEPC)
RTO Project Summary - Summary of RTO Directed Projects
Revenue Requirement of SPP Projects included in SEPC's Projected Revenue Requirements (Note D):
For the 12 months ended - December 31, 2018

Balanced Portfolio Projects (continued)

Line	Project ID	Project Description	(k) <u>Return Adder</u> (A-9 as applicable)	(l)	(m) <u>Total Return</u> (f*i)+(f*k)	(n) <u>Projected Depr Expense</u> (a * d)	(o) <u>Rev. Req w/o True-up</u> (g+h+j+m+n)	(p) <u>True-up Adjustment</u> (o * L18)	(s) <u>Adj. Revenue Requirement</u> (o + p)	(t) <u>Eff. Carrying Charge Rate (D)</u> (q / f)
79	Actual Balanced Portfolio Projects (Inputs from Worksheet A-7)									
80	0	0	0.00%		\$ -	\$ -	\$ -	\$ -		
81	0	0	0.00%		\$ -	\$ -	\$ -	\$ -		
82	0	0	0.00%		\$ -	\$ -	\$ -	\$ -		
83										
84	Total of Actual Balanced Portfolio Projects				\$ -	\$ -	\$ -	\$ -	\$ -	
85										
86										
87										
88	<u>Project ID</u>	<u>Project Description</u>	<u>Return Adder</u>		<u>Total Return</u>	<u>Projected Depr Expense</u>	<u>Rev. Req w/o True-up</u>	<u>True-up Adjustment</u>	<u>Adj. Revenue Requirement</u>	<u>Eff. Carrying Charge Rate (D)</u>
89			(P-1 as applicable)		(f*i)+(f*k)	(P-4)	(g+h+j+m+n)	N.A.	(o + p)	(q / f)
90	Projected Balanced Portfolio Projects (Input from Worksheet P-4)									
91	0	Description	0.00%		\$ -	\$ -	\$ -		\$ -	
92	0	Description	0.00%		\$ -	\$ -	\$ -		\$ -	
93	0	Description	0.00%		\$ -	\$ -	\$ -		\$ -	
94										
95	Total of Projected Balanced Portfolio Projects				\$ -	\$ -	\$ -		\$ -	
96										
97	Total Balanced Portfolio Projects (L84 + L95)				\$ -	\$ -	\$ -		\$ -	

(D) Effective carrying charge rate as a percent of net plant before true up is applied.

Sunflower Electric Power Corporation (SEPC)
RTO Project Summary - Summary of RTO Directed Projects
Revenue Requirement of SPP Projects included in SEPC's Projected Revenue Requirements (Note D):
For the 12 months ended - December 31, 2018

ITP/Priority 1 Projects

Note A: All line references are to page 1 of this worksheet.

Note B: To be completed with any ITP1 project approved by the Southwest Power Pool.

Note C: This tab shows the amount in column s that SPP is required to recover for each ITP1 project.

Line	Project ID	Project Description	In Service Date	(a)	(b)	(c)	(d)	(e)	(f)	(g)	(h)	(i)	(j)
				Plant in Service @ 12/16 (WP A-7)	Accum Depr. @ 12/16 (WP A-7)	Actual Net Plant @ 12/16 (a - b)	Depreciation Rate (WP A-5)	Proj. Additional Accum Depr 1.5 * (a * d)	Projected Net Plant (a - b - e)	O&M Expenses (f * L8)	Other Taxes (f * L10)	Non-Incentive Return (L16)	General Plant Allocation (f * L15)
98	Actual ITP/Priority 1 Projects (Inputs from Worksheet A-7)												
99	0	0		\$ -	-	\$ -	1.69%	\$ -	\$ -	\$ -	\$ -	8.32%	\$ -
100	0	0		\$ -	-	\$ -	1.69%	\$ -	\$ -	\$ -	\$ -	8.32%	\$ -
101	0	0		\$ -	-	\$ -	1.69%	\$ -	\$ -	\$ -	\$ -	8.32%	\$ -
102													
103	Total of Actual ITP/Priority 1 Projects			\$ -	\$ -	\$ -		\$ -	\$ -	\$ -	\$ -		\$ -
104													
105													
106													
107	<u>Project ID</u>	<u>Project Description</u>	<u>In Service Date</u>	13 mo. Avg. Plant in Service 2018				13 mo. Avg. Projected Accum Depr	Projected Net Plant	O&M Expenses	Other Taxes	Non-Incentive Return	General Plant Allocation
108				(WP P-4)				(WP P-4)	(a - e)	(f * L8)	(f * L10)	(L16)	(f * L15)
109	Projected ITP/Priority 1 Projects (Inputs from Worksheet P-4)												
110	0	Description		\$ -				\$ -	\$ -	\$ -	\$ -	8.32%	\$ -
111	0	Description		\$ -				\$ -	\$ -	\$ -	\$ -	8.32%	\$ -
112	0	Description		\$ -				\$ -	\$ -	\$ -	\$ -	8.32%	\$ -
113													
114	Total of Projected ITP/Priority 1 Projects			\$ -				\$ -	\$ -	\$ -	\$ -		\$ -
115													
116	Total ITP/Priority 1 Projects (L103 + L114)			\$ -				\$ -	\$ -	\$ -	\$ -		\$ -

Sunflower Electric Power Corporation (SEPC)
RTO Project Summary - Summary of RTO Directed Projects
Revenue Requirement of SPP Projects included in SEPC's Projected Revenue Requirements (Note D):
For the 12 months ended - December 31, 2018

ITP/Priority 1 Projects (continued)

Line	Project ID	Project Description	(k) <u>Return Adder</u> (A-9 as applicable)	(l)	(m) <u>Total Return</u> (f*i)+(f*k)	(n) <u>Projected Depr Expense</u> (a * d)	(o) <u>Rev. Req w/o True-up</u> (g+h+j+m+n)	(p) <u>True-up Adjustment</u> (o * L18)	(s) <u>Adj. Revenue Requirement</u> (o + p)	(t) <u>Eff. Carrying Charge Rate (D)</u> (q / f)
98	Actual ITP/Priority 1 Projects (Inputs from Worksheet A-7)									
99	0	0	0.00%		\$ -	\$ -	\$ -	\$ -	\$ -	
100	0	0	0.00%		\$ -	\$ -	\$ -	\$ -	\$ -	
101	0	0	0.00%		\$ -	\$ -	\$ -	\$ -	\$ -	
102										
103	Total of Actual ITP/Priority 1 Projects				\$ -	\$ -	\$ -	\$ -	\$ -	
104										
105										
106										
107	<u>Project ID</u>	<u>Project Description</u>	<u>Return Adder</u>		<u>Total Return</u>	<u>Projected Depr Expense</u>	<u>Rev. Req w/o True-up</u>	<u>True-up Adjustment</u>	<u>Adj. Revenue Requirement</u>	<u>Eff. Carrying Charge Rate (D)</u>
108			(P-1 as applicable)		(f*i)+(f*k)	(P-4)	(g+h+j+m+n)	N.A.	(o + p)	(q / f)
109	Projected ITP/Priority 1 Projects (Inputs from Worksheet P-4)									
110	0	Description	0.00%		\$ -	\$ -	\$ -		\$ -	
111	0	Description	0.00%		\$ -	\$ -	\$ -		\$ -	
112	0	Description	0.00%		\$ -	\$ -	\$ -		\$ -	
113										
114	Total of Projected ITP/Priority 1 Projects				\$ -	\$ -	\$ -		\$ -	
115										
116	Total ITP/Priority 1 Projects (L103 + L114)				\$ -	\$ -	\$ -		\$ -	

(D) Effective carrying charge rate as a percent of net plant before true up is applied.

Sunflower Electric Power Corporation (SEPC)
RTO Project Summary - Summary of RTO Directed Projects
Revenue Requirement of SPP Projects included in SEPC's Projected Revenue Requirements (Note D):
For the 12 months ended - December 31, 2018

ITP/Priority 2 Projects

Note A: All line references are to page 1 of this worksheet.

Note B: To be completed with any ITP2 project approved by the Southwest Power Pool.

Note C: This tab shows the amount in column s that SPP is required to recover for each ITP2 project.

Line	Project ID	Project Description	In Service Date	(a)	(b)	(c)	(d)	(e)	(f)	(g)	(h)	(i)	(j)
				Plant in Service @ 12/16 (WP A-7)	Accum Depr. @ 12/16 (WP A-7)	Actual Net Plant @ 12/16 (a - b)	Depreciation Rate (WP A-5)	Proj. Additional Accum Depr 1.5* (a * d)	Projected Net Plant (a - b - e)	O&M Expenses (f * L8)	Other Taxes (f * L10)	Non-Incentive Return (L16)	General Plant Allocation (f * L15)
117	Actual ITP/Priority 2 Projects (Inputs from Worksheet A-7)												
118	0	0		\$ -	-	\$ -	1.69%	\$ -	\$ -	\$ -	\$ -	8.32%	\$ -
119	0	0		\$ -	-	\$ -	1.69%	\$ -	\$ -	\$ -	\$ -	8.32%	\$ -
120	0	0		\$ -	-	\$ -	1.69%	\$ -	\$ -	\$ -	\$ -	8.32%	\$ -
121													
122	Total of Actual ITP/Priority 2 Projects			\$ -	\$ -	\$ -		\$ -	\$ -	\$ -	\$ -		\$ -
123													
124													
125													
126	<u>Project ID</u>	<u>Project Description</u>	<u>In Service Date</u>	13 mo. Avg. Plant in Service 2018				13 mo. Avg. Projected Accum Depr	Projected Net Plant	O&M Expenses	Other Taxes	Non-Incentive Return	General Plant Allocation
127				(WP P-4)				(WP P-4)	(a - e)	(f * L8)	(f * L10)	(L16)	(f * L15)
128	Projected ITP/Priority 2 Projects (Inputs from Worksheet P-4)												
129	0	Description		\$ -				\$ -	\$ -	\$ -	\$ -	8.32%	\$ -
130	0	Description		\$ -				\$ -	\$ -	\$ -	\$ -	8.32%	\$ -
131	0	Description		\$ -				\$ -	\$ -	\$ -	\$ -	8.32%	\$ -
132													
133	Total of Projected ITP/Priority 2 Projects			\$ -				\$ -	\$ -	\$ -	\$ -		\$ -
134													
135	Total ITP/Priority 2 Projects (L122 + L133)			\$ -				\$ -	\$ -	\$ -	\$ -		\$ -

Sunflower Electric Power Corporation (SEPC)
RTO Project Summary - Summary of RTO Directed Projects
Revenue Requirement of SPP Projects included in SEPC's Projected Revenue Requirements (Note D):
For the 12 months ended - December 31, 2018

ITP/Priority 2 Projects (continued)

Line	Project ID	Project Description	(k) <u>Return Adder</u> (A-9 as applicable)	(l)	(m) <u>Total Return</u> (f*i)+(f*k)	(n) <u>Projected Depr Expense</u> (a * d)	(o) <u>Rev. Req w/o True-up</u> (g+h+j+m+n)	(p) <u>True-up Adjustment</u> (o * L18)	(s) <u>Adj. Revenue Requirement</u> (o + p)	(t) <u>Eff. Carrying Charge Rate (D)</u> (q / f)
117	Actual ITP/Priority 2 Projects (Inputs from Worksheet A-7)									
118	0	0	0.00%		\$ -	\$ -	\$ -	\$ -	\$ -	
119	0	0	0.00%		\$ -	\$ -	\$ -	\$ -	\$ -	
120	0	0	0.00%		\$ -	\$ -	\$ -	\$ -	\$ -	
121										
122	Total of Actual ITP/Priority 2 Projects				\$ -	\$ -	\$ -	\$ -	\$ -	
123										
124										
125										
126	<u>Project ID</u>	<u>Project Description</u>	<u>Return Adder</u>		<u>Total Return</u>	<u>Projected Depr Expense</u>	<u>Rev. Req w/o True-up</u>	<u>True-up Adjustment</u>	<u>Adj. Revenue Requirement</u>	<u>Eff. Carrying Charge Rate (D)</u>
127			(P-1 as applicable)		(f*i)+(f*k)	(P-4)	(g+h+j+m+n)	N.A.	(o + p)	(q / f)
128	Projected ITP/Priority 2 Projects (Inputs from Worksheet P-4)									
129	0	Description	0.00%		\$ -	\$ -	\$ -		\$ -	
130	0	Description	0.00%		\$ -	\$ -	\$ -		\$ -	
131	0	Description	0.00%		\$ -	\$ -	\$ -		\$ -	
132										
133	Total of Projected ITP/Priority 2 Projects				\$ -	\$ -	\$ -		\$ -	
134										
135	Total ITP/Priority 2 Projects (L122 + L133)				\$ -	\$ -	\$ -		\$ -	

(D) Effective carrying charge rate as a percent of net plant before true up is applied.

Sunflower Electric Power Corporation (SEPC)
Sponsor Funded Project Summary
Revenue Requirement for Sponsor Funded Projects (SFP) included in SEPC's Projected Revenue Requirements
For the 12 months ended - December 31, 2018

Note A: All line references are to "RTO Project Smry" Workpaper, Pg 1.
Note B: To be completed with any projects sponsored by the host transmission owner.

<u>Line</u>	<u>Project ID</u>	<u>Project Description</u>	<u>In Service Date</u>	(a) <u>Plant in Service @ 12/16</u> (WP A-8)	(b) <u>Actual Accum Depr. @ 12/16</u> (WP A-8)	(c) <u>Actual Net Plant @ 12/16</u> (a - b)	(d) <u>Depreciation Rate</u> (WP A-5 Rev)	(e) <u>Projected Added Accum. Depr.</u> 1.5 * (a * d)	(f) <u>Projected Net Plant</u> (a - b - e)	(g) <u>O&M Expenses</u> (f * L8)	(h) <u>Other Taxes</u> (f * L10)	(i) <u>General Plant Allocation</u> (f * L15)	(j) <u>Non-Incentive Return</u> (L16)
1	Actual Sponsored Projects (Inputs from Worksheet A-8)												
2				\$ -	\$ -	\$ -	1.69%	\$ -	\$ -	\$ -	\$ -	\$ -	8.32%
3				\$ -	\$ -	\$ -	1.69%	\$ -	\$ -	\$ -	\$ -	\$ -	8.32%
4				\$ -	\$ -	\$ -	1.69%	\$ -	\$ -	\$ -	\$ -	\$ -	8.32%
5													
6	Total of Actual Sponsored Projects			\$ -	\$ -	\$ -		\$ -	\$ -	\$ -	\$ -	\$ -	
7													
8													
9			<u>In Service Date</u>	<u>Projected Plant in Service @ 12/18</u> (WP P-5)				<u>Projected Accum Depr</u> (WP P-5)	<u>Projected Net Plant</u> (a - e)	<u>O&M Expenses</u> (f * L8)	<u>Other Taxes</u> (f * L10)	<u>General Plant Allocation</u> (f * L15)	<u>Non-Incentive Return</u> (L16)
10	<u>Project ID</u>	<u>Project Description</u>											
11	Projected Sponsored Projects (Inputs from Worksheet P-5)												
12				\$ -				\$ -	\$ -	\$ -	\$ -	\$ -	8.32%
13				\$ -				\$ -	\$ -	\$ -	\$ -	\$ -	8.32%
14				\$ -				\$ -	\$ -	\$ -	\$ -	\$ -	8.32%
15													
16													
17	Total of Projected Sponsored Projects			\$ -				\$ -	\$ -	\$ -	\$ -	\$ -	
18													
19	Total Sponsored Projects (L6 + L17)			\$ -				\$ -	\$ -	\$ -	\$ -	\$ -	

Sunflower Electric Power Corporation (SEPC)
Sponsor Funded Project Summary
Revenue Requirement for Sponsor Funded Projects (SFP) included in SEPC's Projected Revenue Requirements
For the 12 months ended - December 31, 2018

<u>Line</u>	<u>Project ID</u>	<u>Project Description</u>	(k) <u>Return Adder</u> (P-1 as applicable)	(l)	(m) <u>Total Return</u> (f*j)+(f*k)	(n) <u>Proj. Depr Expense</u> (a * d)	(o) <u>Rev. Req w/o True-up</u> (g+h+i+m+n)	(p) <u>True-up Adjustment</u> (o * L18)	(q) <u>Adj. Revenue Requirement</u> (o + p)	(r) <u>Eff. Carrying Charge Rate (C)</u> (o / f)
1	Actual Sponsored Projects (Inputs from Worksheet A-8)									
2	0	0	0.00%		\$ -	\$ -	\$ -	\$ -	\$ -	
3	0	0	0.00%		\$ -	\$ -	\$ -	\$ -	\$ -	
4	0	0	0.00%		\$ -	\$ -	\$ -	\$ -	\$ -	
5										
6	Total of Actual Sponsored Projects				\$ -	\$ -	\$ -	\$ -	\$ -	
7										
8										
9										
10	<u>Project ID</u>	<u>Project Description</u>	<u>Return Adder</u> (P-1 as applicable)		<u>Total Return</u> (f*j)+(f*k)	<u>Proj. Depr Expense</u> (P-5)	<u>Rev. Req w/o True-up</u> (g+h+i+m+n)	<u>True-up Adjustment</u> N.A.	<u>Adj. Revenue Requirement</u> (o + p)	<u>Eff. Carrying Charge Rate (C)</u> (o / f)
11	Projected Sponsored Projects (Inputs from Worksheet P-5)									
12	0	0	0.00%		\$ -	\$ -	\$ -		\$ -	
13	0	0	0.00%		\$ -	\$ -	\$ -		\$ -	
14	0	0	0.00%		\$ -	\$ -	\$ -		\$ -	
15										
16	Total of Projected Sponsored Projects				\$ -	\$ -	\$ -		\$ -	
17										
18	Total Sponsored Projects (L6 + L17)				\$ -	\$ -	\$ -		\$ -	
19										

(C) Effective carrying charge rate as a percent of net plant before true up is applied.

Sunflower Electric Power Corporation (SEPC)
Third Party Project Summary
Revenue Requirements for Third Party Projects included in SEPC's Projected Revenue Requirements
For the 12 months ended - December 31, 2018

Note A: All line references are to "RTO Project Smry" Workpaper, Pg 1.

Note B: To be completed with any projects sponsored by the host transmission owner.

<u>Line</u>	<u>Project ID</u>	<u>Project Description</u>	<u>In Service Date</u>	<u>Third Party</u>	(a) <u>Plant in Service @ 12/16</u> (WP A-10)	(b) <u>Actual Accum Depr. @ 12/16</u> (WP A-10)	(c) <u>Actual Net Plant @ 12/16</u> (a - b)	(d) <u>Depreciation Rate</u> (WP A-5 Rev)	(e) <u>Projected Added Accum. Depr.</u> 1.5 * (a * d)	(f) <u>Projected Net Plant</u> (a - b - e)	(g) <u>O&M Expenses</u> (f * L8)	(h) <u>Other Taxes</u> (f * L10)	(i) <u>General Plant Allocation</u> (f * L15)
1	Actual Third Party Projects (Inputs from Worksheet A-8)												
2	0	0			\$ -	\$ -	\$ -	1.69%	\$ -	\$ -	\$ -	\$ -	\$ -
3	0	0			\$ -	\$ -	\$ -	1.69%	\$ -	\$ -	\$ -	\$ -	\$ -
4	0	0			\$ -	\$ -	\$ -	1.69%	\$ -	\$ -	\$ -	\$ -	\$ -
5													
6	Total of Third Party Projects				\$ -	\$ -	\$ -		\$ -	\$ -	\$ -	\$ -	\$ -
7													
8													
9			<u>In Service Date</u>		<u>Projected Plant in Service @ 12/18</u> (WP P-6)				<u>Projected Accum Depr</u> (WP P-6)	<u>Projected Net Plant</u> (a - e)	<u>O&M Expenses</u> (f * L8)	<u>Other Taxes</u> (f * L10)	<u>General Plant Allocation</u> (f * L15)
10	<u>Project ID</u>	<u>Project Description</u>											
11													
12	Projected Third Party Projects (Inputs from Worksheet P-5)												
13	0	Description			\$ -				\$ -	\$ -	\$ -	\$ -	\$ -
14	0	Description			\$ -				\$ -	\$ -	\$ -	\$ -	\$ -
15	0	Description			\$ -				\$ -	\$ -	\$ -	\$ -	\$ -
16													
17	Total of Projected Third Party Projects				\$ -				\$ -	\$ -	\$ -	\$ -	\$ -
18													
19	Total Third Party Projects (L6 + L17)				\$ -				\$ -	\$ -	\$ -	\$ -	\$ -

Sunflower Electric Power Corporation (SEPC)
Third Party Project Summary
Revenue Requirements for Third Party Projects included in SEPC's Projected Revenue Requirements
For the 12 months ended - December 31, 2018

	(j)	(k)	(l)	(m)	(n)	(o)	(p)	(q)	(r)	
<u>Project ID</u>	<u>Project Description</u>	<u>Non-Incentive Return</u>	<u>Return Adder</u>	<u>Total Return</u>	<u>Proj. Depr Expense</u>	<u>Rev. Req w/o True-up</u>	<u>True-up Adjustment</u>	<u>Adj. Revenue Requirement</u>	<u>Eff. Carrying Charge Rate (C)</u>	
		(L16)	P-1 as applicable)	(f*j)+(f*k)	(a * d)	(g+h+i+m+n)	(o * L18)	(o + p)	(o / f)	
1	Actual Third Party Projects (Inputs from Worksheet A-8)									
2	0	0		\$ -	\$ -	\$ -	\$ -	\$ -		
3	0	0		\$ -	\$ -	\$ -	\$ -	\$ -		
4	0	0		\$ -	\$ -	\$ -	\$ -	\$ -		
5	<hr/>									
6	Total of Third Party Projects			\$ -	\$ -	\$ -	\$ -	\$ -		
7										
8										
9	Non-Incentive									
10	<u>Project ID</u>	<u>Project Description</u>	<u>Return</u>	<u>Return Adder</u>	<u>Total Return</u>	<u>Proj. Depr Expense</u>	<u>Rev. Req w/o True-up</u>	<u>True-up Adjustment</u>	<u>Adj. Revenue Requirement</u>	<u>Eff. Carrying Charge Rate (C)</u>
11			(L16)	P-1 as applicable)	(f*j)+(f*k)	(P-5)	(g+h+i+m+n)	N.A.	(o + p)	(o / f)
12	Projected Third Party Projects (Inputs from Worksheet P-5)									
13	0	Description	8.32%	0.00%	\$ -	\$ -	\$ -		\$ -	
14	0	Description	8.32%	0.00%	\$ -	\$ -	\$ -		\$ -	
15	0	Description	8.32%	0.00%	\$ -	\$ -	\$ -		\$ -	
16	<hr/>									
17	Total of Projected Third Party Projects				\$ -	\$ -	\$ -		\$ -	N.A.
18	<hr/>									
19	Total Third Party Projects (L6 + L17)				\$ -	\$ -	\$ -		\$ -	N.A.

(C) Effective carrying charge rate as a percent of net plant before true up is applied.

Sunflower Electric Power Corporation (SEPC)
Rate Formula Template
Projected Net Revenue Requirements
For the 12 months ended - December 31, 2018

Line	(1) Description	(2) Reference	(3)	(4)	(5) Amount
	<u>A. GROSS REVENUE REQUIREMENT</u> (including approved incentives, if any)				
1	Total Transmission Facilities	Projected Gross Rev Req, Pg.2, L92			\$ 28,160,611
2					
3	Base Plan Gross Revenue Requirements	WP RTO Project Smry, Base Plan Section, L40 + L59 + L78	\$ 10,147,658		
4	Balanced Portfolio Gross Revenue Requirement	WP RTO Project Smry, Base Plan Section, L97	-		
5	ITP/Priority Projects-1 Gross Revenue Requirement	WP RTO Project Smry, Base Plan Section, L116	-		
6	ITP/Priority Projects-2 Gross Revenue Requirement	WP RTO Project Smry, Base Plan Section, L135	-		
7	Sponsored Projects Gross Revenue Requirements	WP Spon Project Smry, L19	-		
8	Third Party Projects Gross Revenue Requirements	WP Third Party Project Smry, L19	-		
9	Total	Sum (L3:L7)			\$ 10,147,658
10					
11	Zonal Gross Revenue Requirement	L1 - L9			\$ 18,012,953
12					
13	<u>B. REVENUE CREDITS</u>				
14	Zonal Gross Revenue Credit	WP P-2, L48			\$ 5,871,333
15					
16	<u>C. NET REVENUE REQUIREMENT AFTER REVENUE CREDITS AND BEFORE TRUE-UP</u>				
17	Base Plan Net Revenue Requirements	L3	\$ 10,147,658		
18	Balanced Portfolio Net Revenue Requirement	L4	-		
19	ITP/Priority Projects-1 Net Revenue Requirement	L5	-		
20	ITP/Priority Projects-2 Net Revenue Requirement	L6	-		
21	Sponsored Projects Net Revenue Requirements	L7	-		
22	Third Party Projects Net Revenue Requirements	L8	-		
23	Total	Sum (L17:L22)		\$ 10,147,658	
24					
25	Zonal Net Revenue Requirement	L11 - L14			\$ 12,141,619
26					
27	<u>D. TRUE-UP ADJUSTMENTS</u>				
28	Total Transmission Facilities	WP TU (True-Up), L18		\$ (2,809,536)	
29					
30	Base Plan True-Up	WP TU (True-Up), L18	\$ (832,275)		
31	Balanced Portfolio True-Up	WP TU (True-Up), L18	-		
32	ITP/Priority Projects-1 True-UP	WP TU (True-Up), L18	-		
33	ITP/Priority Projects-2 True-UP	WP TU (True-Up), L18	-		
34	Sponsored Projects True Up	WP TU (True-Up), L18	-		
35	Third Party Projects True Up	WP TU (True-Up), L18	-		
36	Total	Sum (L30:L33)		\$ (832,275)	
37					
38	Zonal True-Up Revenue Requirement	L28 - L36			\$ (1,977,260)
39					
40	<u>E. NET REVENUE REQUIREMENT AFTER TRUE-UP</u>				
41	Base Plan Net Revenue Requirements	L17 + L30	\$ 9,315,383		
42	Balanced Portfolio Net Revenue Requirement	L18 + L31	-		
43	ITP/Priority Projects-1 Net Revenue Requirement	L19 + L32	-		
44	ITP/Priority Projects-2 Net Revenue Requirement	L20 + L33	-		
45	Sponsored Projects Net Revenue Requirements	L21 + L34	-		
46	Third Party Projects Net Revenue Requirements	L22 + L35	-		
47	Total	Sum (L41:L46)		\$ 9,315,383	
48					
49	Zonal Net Revenue Requirement	L25 + L38			\$ 10,164,359
50					
51	<u>F. Point-to-Point Service</u>				
52	Projected SEPC Zone 9 SPP Aver. 12-Mo. Peak Demand	WP P-3 (Trans. Network Load), L15			376.14 MW
53					
54	Annual Point-to-Point Rate in \$/MW - Year	L49 / L52			\$ 27,023.00
55	Monthly Point-to-Point Rate in \$/MW - Month	L54 / 12 months			\$ 2,252.00
56	Weekly Point-to-Point Rate in \$/MW- Weekly	L54 / 52 weeks			\$ 520.00
57	Daily On-Peak Point-to-Point Rate in \$/MW - Day	L54 / 260 days			\$ 103.90
58	Daily Off-Peak Point-to-Point Rate in \$/MW - Day	L54 / 365 days			\$ 74.00
59	Hourly On-Peak Point-to-Point Rate in \$/MW - Hour	L57 / 16 hours			\$ 6.49
60	Hourly Off-Peak Point-to-Point Rate in \$/MW - Hour	L58 / 24 hours			\$ 3.08
61					

**Sunflower Electric Power Corporation (SEPC)
Projected Gross Revenue Requirements
For the 12 months ended - December 31, 2018**

<u>Line</u>	<u>(1) Description</u>	<u>(2) KCC Annual Report/Worksheet</u>	<u>(3) Total Company</u>	<u>(4)</u>	<u>(5) Allocator</u>	<u>(6) Transmission (Col. 3 times Col. 5)</u>
RATE BASE:						
1	PLANT IN SERVICE (13 Month Averages)					
2	Production	Act. Gross Rev Req, Pg.1, L3	\$ 532,089,083	NA		
3	Transmission (Excludes Capital & Operating Leases)	WP P-1, Pg. 4 L156	157,843,385	DA	1.00000	\$ 157,843,385
4	Less Excluded Plant	Act. Gross Rev Req, Pg.1, L5		DA	1.00000	3,631,278
5	Distribution	Act. Gross Rev Req, Pg.1, L6	-	NA		
6	General	Act. Gross Rev Req, Pg.1, L7	47,383,379	PWS	0.26824	12,710,337
7	Intangible & Other	Act. Gross Rev Req, Pg.1, L8	-	PWS	0.26824	-
8	TOTAL GROSS PLANT	L2 + L3 - L4 + L5 + L6 + L7	\$ 737,315,847			\$ 166,922,445
9						
10	ACCUMULATED DEPRECIATION (13 Month Averages)					
11	Production	Act. Gross Rev Req, Pg.1, L12	\$ 363,756,803	NA		
12	Transmission (Excludes Capital & Operating Leases)	WP P-1, Pg. 4 L156	85,825,916	DA	0.97263	\$ 85,825,916
13	Less Excluded Plant	Act. Gross Rev Req, Pg.1, L14		DA	1.00000	2,227,462.00
14	Distribution	Act. Gross Rev Req, Pg.1, L15	-	NA		
15	General	Act. Gross Rev Req, Pg.1, L16	23,824,313	PWS	0.26824	6,390,744
16	Intangible & Other	Act. Gross Rev Req, Pg.1, L17	-	PWS	0.26824	-
17	TOTAL ACCUM. DEPRECIATION	L11 + L12 - L13 + L14 + L15 + L16	\$ 473,407,032			\$ 89,989,199
18						
19	NET PLANT IN SERVICE (13 Month Averages)					
20	Production	L2 - L11	\$ 168,332,280			
21	Transmission (Excludes Capital & Operating Leases)	L3 - L12	72,017,469			\$ 72,017,469
22	Less Excluded Plant	L4 - L13				1,403,816
23	Distribution	L5 - L14	-			-
24	General	L6 - L15	23,559,066			6,319,593
25	Intangible & Other	L7 - L16	-			-
26	TOTAL NET PLANT	L20 + L21 - L22 + L23 + L24 + L25	\$ 263,908,815			\$ 76,933,246
27						
28	ADJUSTMENTS TO RATE BASE					
29	Accumulated Deferred Income Taxes	Act. Gross Rev Req, Pg.1, L38	\$ -	DA	1.00000	\$ -
30	Unrefunded Customer Advances for Construction	Note A	-	DA	1.00000	-
31	Reserve Funds (Non-Escrowed)	Act. Gross Rev Req, Pg.1, L40	-	DA	1.00000	-
32	Unamortized Abandoned Transmission Plant	Act. Gross Rev Req, Pg.1, L41 - Amortization	-	DA	1.00000	-
33	TOTAL ADJUSTMENTS	Sum (L29:L32)	\$ -			\$ -
34						
35	LAND HELD FOR FUTURE USE	Act. Gross Rev Req, Pg.1, L44	\$ -	DA	1.00000	\$ -
36						
37	WORKING CAPITAL					
38	CWC					
39	O&M Expense less Fuel & Purchased Power	Act. Gross Rev Req, Pg.1, L48	\$ 94,184,341	NA		
40	O&M Expense Allocated to Transmission	Pg. 2, L65, Col (6)				\$ 19,375,069
41	Calculated CWC	Calculated (Note C)	\$ 11,773,043			\$ 2,421,884
42	Materials & Supplies-Transmission	Act. Gross Rev Req, Pg.1, L51	1,536,946	PTP	0.98409	1,512,488
43	Materials & Supplies-Other	Act. Gross Rev Req, Pg.1, L52	12,593,870	NA		
44	Stores Expense	Act. Gross Rev Req, Pg.1, L53	-	PWS	0.26824	-
45	Prepayments (Account 165)	Act. Gross Rev Req, Pg.1, L54	1,231,563	GP	0.23373	287,858
46						
47	TOTAL WORKING CAPITAL	Sum (L41:L46)	\$ 27,135,422			\$ 4,222,229
48						
49	Rate Base	L26 + L 33 + L 35 + L47	\$ 291,044,237			\$ 81,155,475

**Sunflower Electric Power Corporation (SEPC)
Projected Gross Revenue Requirements
For the 12 months ended - December 31, 2018**

<u>Line</u>	<u>(1) Description</u>	<u>(2) KCC Annual Report/Worksheet</u>	<u>(3) Total Company</u>	<u>(4)</u>	<u>(5) Allocator</u>	<u>(6) Transmission (Col. 3 times Col. 5)</u>
50	O&M					
51	Transmission	WP P-2, L10	\$ 47,151,938			
52	Less Account 565	WP P-2, L11	30,802,312			
53	Less: Trans. Lease Payments & Facility Charge	WP P-2, L12	5,080,753			
54	Less Acct. 561 Expense Recovered Through Sch. 1	Projected Schedule 1 Rev Req, L6	1,523,825			
55	Total Transmission O&M	L51 - Sum (L52:L53)	\$ 9,745,049	PTP	0.98409	\$ 9,589,969
56	A&G -Adjusted	WP P-2, L15	\$ 15,826,338	PWS	0.26824	\$ 4,245,330
57	Plus: Advertising -Safety	WP P-2, L16	-	PWS	0.26824	-
58	Plus Association Dues Directly Related to Transmission	WP P-2, L17	-	DA	1.00000	-
59	Plus: Advertising -Transmission	WP P-2, L18	-	DA	1.00000	-
60	Plus: Research -Transmission	WP P-2, L19	-	DA	1.00000	-
61	Plus: Regulatory Exp -Transmission	WP P-2, L20	26,840	DA	1.00000	26,840
62	Plus: Corporate Visibility -Transmission	WP P-2, L21	-	PWS	0.26824	-
63	Total A&G	L56 + Sum (L57:L62)	\$ 15,853,178			\$ 4,272,170
64	Transmission Lease Payments & Facility Charges	WP P-2, L14	5,512,930	DA	1.00000	5,512,930
65	TOTAL O&M	L55 + L63 + L64	\$ 31,111,156			\$ 19,375,069
66						
67	DEPRECIATION EXPENSE					
68	Production	Act. Gross Rev Req, Pg. 2, L77	\$ 7,782,979	NA		
69	Transmission	WP P-1, Pg.2 L155	2,642,919	PTP	0.98409	\$ 2,600,861
70	Distribution	Act. Gross Rev Req, Pg. 2, L79	-	NA		
71	General	Act. Gross Rev Req, Pg. 2, L80	2,365,501	PWS	0.26824	634,533
72	Intangible & Other	Act. Gross Rev Req, Pg. 2, L81	-	PWS	0.26824	-
73	Amortization of Abandon Transmission Plant	Act. Gross Rev Req, Pg. 2, L82	-	DA	1.00000	-
74	TOTAL DEPRECIATION	Sum (L68:L73)	\$ 12,791,399			\$ 3,235,394
75						
76	TAXES OTHER THAN INCOME TAXES (Note G)					
77	LABOR RELATED					
78	Payroll	WP P-2, L25	\$ -	PWS	0.26824	\$ -
79	Highway and vehicle	WP P-2, L26	-	PWS	0.26824	-
80	PLANT RELATED					
81	Property	WP P-2, L28	-	GP	0.23861	-
82	Gross Receipts	WP P-2, L29	-	NA		-
83	Other	WP P-2, L30	425	GP	0.23861	101
84						
85	TOTAL OTHER TAXES	Sum (L78:L84)	\$ 425			\$ 101
86						
87	RETURN					
88	Return before incentives	Pg. 4, L150				\$ 5,550,047
89	Incentive return	Pg. 4, L178				-
90	Total Return	L88 + L89				\$ 5,550,047
91						
92	GROSS REV. REQ. WITH INCENTIVES	L65 + L74 + L85 + L90				\$ 28,160,611
93	Less: Gross Rev. Req. for Incentives	L178				-
94						
95	GROSS REV. REQ. WITHOUT INCENTIVES	L92 - L93				\$ 28,160,611

**Sunflower Electric Power Corporation (SEPC)
Projected Gross Revenue Requirements
For the 12 months ended - December 31, 2018**

<u>Line</u>	<u>(1) Description</u>	<u>(2) KCC Annual Report/Worksheet</u>	<u>(3) Total Company</u>	<u>(4)</u>	<u>(5) Allocator</u>	<u>(6) Transmission (Col. 3 times Col. 5)</u>
96	TRANSMISSION PLANT INCLUDED IN FORMULA					
97	Total transmission plant, including capital and operating leases	P-1 (Trans Plant), L156 + L187 + L218	\$ 228,186,776	DA	1.00000	\$ 228,186,776
98	Less: Net Substation, 34kV, & Radial Lines to Distr. Plt.	Act. Gross Rev Req, Pg.3, L107		- DA	1.00000	-
99	Less: Total GSU in Transmission Plant	Act. Gross Rev Req, Pg.3, L108		\$ 3,631,278 DA	1.00000	3,631,278
100	Transmission plant included in rates	L97 - L98 - L99	\$ 228,186,776			\$ 224,555,498
101						
102	Percentage of transmission plant included in rates	L100 / L97			PTP= 0.98409	
103						
104	GROSS AND NET PLANT ALLOCATORS					
105	GROSS PLANT IN SERVICE	Use ACTUAL HISTORICAL COST				
106	Production	Act. Gross Rev Req, Pg.3, L114	\$ 532,089,083	NA		
107	Total transmission plant, including leases	Act. Gross Rev Req, Pg.3, L115	165,010,600	DA	1.00000	\$ 165,010,600
108	Less: Excluded Plant	Act. Gross Rev Req, Pg.3, L116	-	DA	1.00000	-
109	Distribution	Act. Gross Rev Req, Pg.3, L117	-	NA		
110	General & Intangible	Act. Gross Rev Req, Pg.3, L118	47,383,379	WS	0.26658	12,631,644
111	TOTAL GROSS PLANT	L106 + L107 - L108 + L109 + L110	\$ 744,483,061		GP = 0.23861	\$ 177,642,244
112						
113	ACCUMULATED DEPRECIATION	Use ACTUAL HISTORICAL COST				
114	Production	Act. Gross Rev Req, Pg.3, L122	\$ 363,756,803	NA		
115	Total transmission plant, including leases	Act. Gross Rev Req, Pg.3, L123	82,381,067	DA	1.00000	\$ 82,381,067
116	Less: Excluded Plant	Act. Gross Rev Req, Pg.3, L124	-	DA	1.00000	-
117	Distribution	Act. Gross Rev Req, Pg.3, L125	-	NA		
118	General & Intangible	Act. Gross Rev Req, Pg.3, L126	23,824,313	WS	0.26658	6,351,177
119	TOTAL ACCUM. DEPRECIATION	L114 + L115 - L116 + L117 + L118	\$ 469,962,182			\$ 88,732,245
120						
121	NET PLANT IN SERVICE	Use ACTUAL HISTORICAL COST				
122	Production	L106 - L114	\$ 168,332,280			
123	Total transmission plant, including leases	L107 - L115	82,629,533			\$ 82,629,533
124	Less: Excluded Plant	L108 - L116	-			-
125	Distribution	L109 - L117	-			-
126	General & Intangible	L110 - L118	23,559,066			6,280,467
127						
128	TOTAL NET PLANT	L122 + L123 - L124 + L125 + L126	\$ 274,520,879		NP = 0.32387	\$ 88,910,000

**Sunflower Electric Power Corporation (SEPC)
Projected Gross Revenue Requirements
For the 12 months ended - December 31, 2018**

<u>Line</u>	<u>(1) Description</u>	<u>(2) KCC Annual Report/Worksheet</u>	<u>(3) Total Company</u>	<u>(4)</u>	<u>(5) Allocator</u>	<u>(6) Transmission (Col. 3 times Col. 5)</u>
	WAGES & SALARY ALLOCATOR (WS)	ACTUAL HISTORICAL COST				
129	Production	Act. Gross Rev Req, Pg.4, L138	\$ 12,507,277			
130	Transmission	Act. Gross Rev Req, Pg.4, L139	4,686,804	PTP	0.98409	\$ 4,612,220
131	Distribution	Act. Gross Rev Req, Pg.4, L140	-			
132	Other	Act. Gross Rev Req, Pg.4, L141	-			
133	Total	Sum (L129:L132)	\$ 17,194,081			\$ 4,612,220
134	Wage & Salary Allocator Calculation	Col 6, L133 / Col 3, L133			PWS= 0.26824	
135						
136						
137						
138						
139						
140						
141	RETURN (R)					
142						
143	RETURN (R)					
144	Net Plant allocated to Transm. 13 mo. avg. 2018, excludes leases)	Projected Gross Rev Req, L26, Col. (6)				\$ 76,933,246
145	Net Plant allocated to Transm. 13 mo. avg. 2016, excludes leases)	Actual Gross Rev Req, L27, Col. (6)				\$ 51,537,906
146	Ratio Net Plant2018 / 2016	L144 / 145				1.4928
147						
148	Transmission Return for 2016 Actual Before Incentives	Act. Gross Rev Req, L97, Col. (6)				\$ 3,718,000
149						
150	Transmission Return for 2018 Projected	L146 * L148				\$ 5,550,047
151						
152	GROSS REV. REQUIREMENT FOR INCENTIVE PROJECTS					
153	Plant Granted Incentive ROE Adder:					
154	Total Incentive Plant	WP P-1, Pg. 1, L38	\$ -			
155	Less: Total Accumulated Depreciation	WP P-1, Pg. 1, L38	-			
156	Net Incentive Plant	L154 - L155	\$ -			
157	Incentive Return	WP P-1, Pg. 1, L41			\$ -	
158						
159						
160						
161						
162						
163	Abandoned Plant:					
164	Unamortized Abandoned Transmission Plant	Pg. 1, L32	\$ -			
165	Return on Abandoned Plant	Actual Gross Rev Req Pg. 4, L174 * L164	-			
166	Amortization Expense for Abandoned Plant	Pg. 2, L73	-			
167	Total Recovery for Abandoned Plant	Sum (L165:L166)			\$ -	
168	TOTAL GROSS REV. REQUIREMENT FOR INCENTIVE PROJ.	L157 + L161 + L167				\$ -
169						
170	INCENTIVE PLANT (excludes CWIP and Abandoned Plant)					
171	Incentive Plant: Projected Base Plan Funded	RTO Project Smry	\$ -	\$ -		\$ -
172	Incentive Plant: Projected Balanced Portfolio	RTO Project Smry	-	-		-
173	Incentive Plant: Projected ITP / Priority Project-1	RTO Project Smry	-	-		-
174	Incentive Plant: Projected ITP / Priority Project-2	RTO Project Smry	-	-		-
175	Incentive Plant: Projected Sponsor Funded	Spon Project Smry	-	-		-
176	Total Incentive Plant	Sum (L171:L175)	\$ -	\$ -		\$ -
177	Note: Incentive gross plant and accumulated depreciation values, if applicable, will be calculated by cell references to the RTO Project Smry and Spon Proj Smry tabs.					
178	Incentive Return	WP P-1, Pg. 1, L41				\$ -

**Sunflower Electric Power Corporation (SEPC)
Projected Gross Revenue Requirements
For the 12 months ended - December 31, 2018**

Notes

- A Reduce Rate Base by Unrefunded Transmission customer advances for construction. This line shall be directly assigned 100% to Transmission. Provide separate workpaper to support adjustment.
- B Hold for future use
- C Cash Working Capital assigned to transmission is one-eighth of O&M allocated to transmission at Pg. 2, L41, Col. 6.
- D Hold for future use

<u>Line No.</u>	<u>Allocators</u>	ALLOCATION FACTORS	<u>Description</u>	<u>Location of Calculation or First Use of Allocator</u>
1	PTP		Percentage of projected transmission plant included in rate base.	L102
2	PWS		Percentage of projected transmission labor included in rates	L134
3	DA		Direct assignment	
4	GP		Ratio of allocated transmission, general, & intangible plant to total gross plant.	L111
5	NA		Not applicable for the transmission formula rate.	
6	NP		Ratio of net transmission, general, & intangible plant to total net plant.	L128
7				

**Sunflower Electric Power Corporation (SEPC)
Rate Formula Template**

**Projected Schedule 1 Revenue Requirements
For the 12 months ended - December 31, 2018**

<u>Line No.</u>	<u>Description</u>	<u>Reference</u>	<u>Amount</u>
A. Projected Schedule 1 ARR			
1	Total Load Dispatch & Scheduling	Actual Sch 1 Rev Req, L1 * (P-2 (Exp. & Rev. Credits) L6, Col 5	\$ 1,523,825
2	Plus: Acct. 556 SPP NERC Compliance Charges	Actual Sch 1 Rev Req, L2 * (P-2 (Exp. & Rev. Credits) L6, Col 5	-
3	Less: Scheduling, System Control and Dispatch Services	Actual Sch 1 Rev Req, L3 * (P-2 (Exp. & Rev. Credits) L6, Col 5	-
4	Less: Transmission Service Studies	Actual Sch 1 Rev Req, L4 * (P-2 (Exp. & Rev. Credits) L6, Col 5	-
5	Less: Reliability, Planning & Standards Dev. Services	Actual Sch 1 Rev Req, L5 * (P-2 (Exp. & Rev. Credits) L6, Col 5	-
6	Total	L1 + L2 - L3 - L4 - L5	<u>\$ 1,523,825</u>
7	Plus: NERC Penalties Associated with Transmission (Acct. 42630)	Actual Sch 1 Rev Req, L7 * (P-2 (Exp. & Rev. Credits) L6, Col 5	-
8	Less: PTP Service Credit	Actual Sch. 1 Rev Req, L8	176,984
9	Revenue Requirement for Schedule 1	L6 + L7 - L8	<u>\$ 1,346,840</u>
10	Prior Year True-Up	L30	<u>(357,885)</u>
11			
12	Net Schedule 1 Revenue Requirement for Zone	L9 + L10	<u>\$ 988,955</u>
13	Acct. 561 Expenses Recovered Through Sch. 1 Charges	L1 - Sum(L3:L5)	\$ 1,523,825
B. Projected Schedule 1 Rate Calculations			
14	SEPC 12-CP. Peak Demand	WP P-3, L15	376.14 MW
15			
16	Annual Point-to-Point Rate in \$/MW - Year	L12 / L14	\$ 2,629.200
17	Monthly Point-to-Point Rate \$/MW - Month	L16 / 12	\$ 219.100
18	Weekly Point-to-Point Rate \$/MW - Week	L16 / 52	\$ 50.560
19	Daily Point-to-Point Rate \$/MW - Day	L16 / 365	\$ 7.203
20	Hourly Point-to-Point Rate \$/MW - Hour	L16 / 8760	\$ 0.300
C. Schedule 1 True-UP			
21	Actual Revenue Requirement for 2016	Actual Sched 1 Rev Req, L9	\$ 1,208,311
22	Projected Revenue Requirement for 2016	Schedule 1 Proj. for the Actual Period (Note C)	<u>1,542,455</u>
23	Revenue Requirement True-Up	L21 - L22	<u>\$ (334,144)</u>
24			
25	Interest on True-Up:		
26	If Actual Revenue Req. > Projected Revenue Req.	L23 * (Min(ST I-Rate or FERC I-Rate)/12) * 24 (Note A)	-
27			
28	If Actual Revenue Req. < Projected Revenue Req.	L23 * (FERC Interest Rate/12) * 24 (Note B)	(23,741)
29			
30	Total Annual True-Up Adjustment	Sum (L23:L28)	<u>\$ (357,885)</u>

Notes:

- A The interest rate for an undercharge is the same rate used in the True -Up schedule.
- B The interest rate for an overcharge is the same rate used in the True -Up schedule.
- C Enter the Projected Revenue Requirement for the Actual period, pending the Actual data. For the initial two years, set this equal to the calculated Actual period since there is no true-up.

**Sunflower Electric Power Corporation (SEPC)
Projected Transmission Plant
For the 12 months ended - December 31, 2018**

Incentive Projects

			<i>Description</i>				<i>Description</i>						
			Project :				Project :						
			Type:			Type:							
			Depr. Rate:(A)	0.1395%		Depr. Rate:(A)	0.1395%						
			DSC Adder (B)	-		DSC Adder (B)	-						
			Avg. Debt Service Rate	4.7556%	Return Adder	0.00%	Avg. Debt Service Rate	4.7556%	Return Adder	0.00%			
			Begin. Plant Bal:	\$ -		Begin. Plant Bal:	\$ -						
			Begin. Acc. Depr:	-		Begin. Acc. Depr:	-						
			Begin. Year-Mo.:			Begin. Year-Mo.:							
Total Incentive Plant													
Mon	Year		Total										
			Gross Plant	Depreciation	Accum. Depr.	Gross Plant	Depreciation	Accum. Depr.	Net Plant	Gross Plant	Depreciation	Accum. Depr.	Net Plant
			\$ -	\$ -	\$ -	\$ -	\$ -	\$ -	\$ -	\$ -	\$ -	\$ -	\$ -
12	Jan	2017	\$ -	\$ -	\$ -	\$ -	\$ -	\$ -	\$ -	\$ -	\$ -	\$ -	\$ -
13	Feb	2017	\$ -	\$ -	\$ -	\$ -	\$ -	\$ -	\$ -	\$ -	\$ -	\$ -	\$ -
14	Mar	2017	\$ -	\$ -	\$ -	\$ -	\$ -	\$ -	\$ -	\$ -	\$ -	\$ -	\$ -
15	Apr	2017	\$ -	\$ -	\$ -	\$ -	\$ -	\$ -	\$ -	\$ -	\$ -	\$ -	\$ -
16	May	2017	\$ -	\$ -	\$ -	\$ -	\$ -	\$ -	\$ -	\$ -	\$ -	\$ -	\$ -
17	Jun	2017	\$ -	\$ -	\$ -	\$ -	\$ -	\$ -	\$ -	\$ -	\$ -	\$ -	\$ -
18	Jul	2017	\$ -	\$ -	\$ -	\$ -	\$ -	\$ -	\$ -	\$ -	\$ -	\$ -	\$ -
19	Aug	2017	\$ -	\$ -	\$ -	\$ -	\$ -	\$ -	\$ -	\$ -	\$ -	\$ -	\$ -
20	Sep	2017	\$ -	\$ -	\$ -	\$ -	\$ -	\$ -	\$ -	\$ -	\$ -	\$ -	\$ -
21	Oct	2017	\$ -	\$ -	\$ -	\$ -	\$ -	\$ -	\$ -	\$ -	\$ -	\$ -	\$ -
22	Nov	2017	\$ -	\$ -	\$ -	\$ -	\$ -	\$ -	\$ -	\$ -	\$ -	\$ -	\$ -
23	Dec	2017	\$ -	\$ -	\$ -	\$ -	\$ -	\$ -	\$ -	\$ -	\$ -	\$ -	\$ -
24	Jan	2018	\$ -	\$ -	\$ -	\$ -	\$ -	\$ -	\$ -	\$ -	\$ -	\$ -	\$ -
25	Feb	2018	\$ -	\$ -	\$ -	\$ -	\$ -	\$ -	\$ -	\$ -	\$ -	\$ -	\$ -
26	Mar	2018	\$ -	\$ -	\$ -	\$ -	\$ -	\$ -	\$ -	\$ -	\$ -	\$ -	\$ -
27	Apr	2018	\$ -	\$ -	\$ -	\$ -	\$ -	\$ -	\$ -	\$ -	\$ -	\$ -	\$ -
28	May	2018	\$ -	\$ -	\$ -	\$ -	\$ -	\$ -	\$ -	\$ -	\$ -	\$ -	\$ -
29	Jun	2018	\$ -	\$ -	\$ -	\$ -	\$ -	\$ -	\$ -	\$ -	\$ -	\$ -	\$ -
30	Jul	2018	\$ -	\$ -	\$ -	\$ -	\$ -	\$ -	\$ -	\$ -	\$ -	\$ -	\$ -
31	Aug	2018	\$ -	\$ -	\$ -	\$ -	\$ -	\$ -	\$ -	\$ -	\$ -	\$ -	\$ -
32	Sep	2018	\$ -	\$ -	\$ -	\$ -	\$ -	\$ -	\$ -	\$ -	\$ -	\$ -	\$ -
33	Oct	2018	\$ -	\$ -	\$ -	\$ -	\$ -	\$ -	\$ -	\$ -	\$ -	\$ -	\$ -
34	Nov	2018	\$ -	\$ -	\$ -	\$ -	\$ -	\$ -	\$ -	\$ -	\$ -	\$ -	\$ -
35	Dec	2018	\$ -	\$ -	\$ -	\$ -	\$ -	\$ -	\$ -	\$ -	\$ -	\$ -	\$ -
37	12 Mon Tot		\$ -	\$ -	\$ -	\$ -	\$ -	\$ -	\$ -	\$ -	\$ -	\$ -	\$ -
38	13 Mon Avg		\$ -	\$ -	\$ -	\$ -	\$ -	\$ -	\$ -	\$ -	\$ -	\$ -	\$ -
39	Total Approved Project Incentives:												
41	Return due to Incentive DSC Adder		\$ -	\$ -	\$ -	Return due to Incentive DSC Adder	\$ -	\$ -	\$ -	Return due to Incentive DSC Adder	\$ -	\$ -	\$ -

(A) Special incentive (Depreciation Rate, TIER, or DSC) may be utilized for specific incentive transmission projects if approved by the FERC.

(B) The formula is set up to accommodate an incentive DSC Adder. If FERC grants an ROE adder, it may be converted to a TIER adder using the following formula: TIER Adder = (ROE Adder * Equity Ratio) / Average System Interest Rate, or to a DSC adder using the following formula: DSC Adder = (ROE Adder * Equity ratio) / Average System Debt Service Rate. If FERC grants a different incentive, the formula may need to be modified accordingly.

**Sunflower Electric Power Corporation (SEPC)
Projected Transmission Plant
For the 12 months ended - December 31, 2018**

Incentive Projects (continued)

		<i>Description</i>				<i>Description</i>				
42		Project :				Project :				
43	Type:									
44	Depr. Rate:(A)		0.1395%				0.1395%			
45	DSC Adder (B)		-				-			
46	Avg. Debt Service Rate		4.7556%	Return Adder	0.00%		4.7556%	Return Adder	0.00%	
47	Begin. Plant Bal:	\$	-			\$	-			
48	Begin. Acc. Depr:		-				-			
49	Begin. Year-Mo.:									
50										
51	Mon	Year	Gross Plant	Depreciation	Accum. Depr.	Net Plant	Gross Plant	Depreciation	Accum. Depr.	Net Plant
52			\$ -				\$ -			
53	Jan	2017	\$ -	\$ -	\$ -	\$ -	\$ -	\$ -	\$ -	\$ -
54	Feb	2017	\$ -	\$ -	\$ -	\$ -	\$ -	\$ -	\$ -	\$ -
55	Mar	2017	\$ -	\$ -	\$ -	\$ -	\$ -	\$ -	\$ -	\$ -
56	Apr	2017	\$ -	\$ -	\$ -	\$ -	\$ -	\$ -	\$ -	\$ -
57	May	2017	\$ -	\$ -	\$ -	\$ -	\$ -	\$ -	\$ -	\$ -
58	Jun	2017	\$ -	\$ -	\$ -	\$ -	\$ -	\$ -	\$ -	\$ -
59	Jul	2017	\$ -	\$ -	\$ -	\$ -	\$ -	\$ -	\$ -	\$ -
60	Aug	2017	\$ -	\$ -	\$ -	\$ -	\$ -	\$ -	\$ -	\$ -
61	Sep	2017	\$ -	\$ -	\$ -	\$ -	\$ -	\$ -	\$ -	\$ -
62	Oct	2017	\$ -	\$ -	\$ -	\$ -	\$ -	\$ -	\$ -	\$ -
63	No	2017	\$ -	\$ -	\$ -	\$ -	\$ -	\$ -	\$ -	\$ -
64	Dec	2017	\$ -	\$ -	\$ -	\$ -	\$ -	\$ -	\$ -	\$ -
65	Jan	2018	\$ -	\$ -	\$ -	\$ -	\$ -	\$ -	\$ -	\$ -
66	Feb	2018	\$ -	\$ -	\$ -	\$ -	\$ -	\$ -	\$ -	\$ -
67	Mar	2018	\$ -	\$ -	\$ -	\$ -	\$ -	\$ -	\$ -	\$ -
68	Apr	2018	\$ -	\$ -	\$ -	\$ -	\$ -	\$ -	\$ -	\$ -
69	May	2018	\$ -	\$ -	\$ -	\$ -	\$ -	\$ -	\$ -	\$ -
70	Jun	2018	\$ -	\$ -	\$ -	\$ -	\$ -	\$ -	\$ -	\$ -
71	Jul	2018	\$ -	\$ -	\$ -	\$ -	\$ -	\$ -	\$ -	\$ -
72	Aug	2018	\$ -	\$ -	\$ -	\$ -	\$ -	\$ -	\$ -	\$ -
73	Sep	2018	\$ -	\$ -	\$ -	\$ -	\$ -	\$ -	\$ -	\$ -
74	Oct	2018	\$ -	\$ -	\$ -	\$ -	\$ -	\$ -	\$ -	\$ -
75	Nov	2018	\$ -	\$ -	\$ -	\$ -	\$ -	\$ -	\$ -	\$ -
76	Dec	2018	\$ -	\$ -	\$ -	\$ -	\$ -	\$ -	\$ -	\$ -
77										
78	Total			\$ -				\$ -		
79	13 Mo. Avg.		\$ -		\$ -		\$ -		\$ -	
80										
81										
82			Return due to Incentive DSC Adder			\$ -	Return due to Incentive DSC Adder			\$ -

(A) Special incentive (Depreciation Rate, TIER, or DSC) may be utilized for specific incentive transmission projects if approved by the FERC.

(B) The formula is set up to accommodate an incentive DSC Adder. If FERC grants an ROE adder, it may be converted to a TIER adder using the following formula: TIER Adder = (ROE Adder * Equity Ratio) / Average System Interest Rate, or to a DSC adder using the following formula: DSC Adder = (ROE Adder * Equity ratio) / Average System Debt Service Rate. If FERC grants a different incentive, the formula may need to be modified accordingly.

**Sunflower Electric Power Corporation (SEPC)
Projected Transmission Plant
For the 12 months ended - December 31, 2018**

Incentive Projects (continued)

		<i>Description</i>				<i>Description</i>				
83		Project :				Project :				
84		Type:				Type:				
85		Depr. Rate:(A)	0.1395%			Depr. Rate:(A)	0.1395%			
86		DSC Adder (B)	-			DSC Adder (B)	-			
87		Avg. Debt Service Rate	4.7556%	Return Adder	0.00%	Avg. Debt Service Rate	4.7556%	Return Adder	0.00%	
88		Begin. Plant Bal:				Begin. Plant Bal:	\$ -			
89		Begin. Acc. Depr:				Begin. Acc. Depr:				
90		Begin. Year-Mo.:				Begin. Year-Mo.:				
91										
92	Mon	Year	Gross Plant	Depreciation	Accum. Depr.	Net Plant	Gross Plant	Depreciation	Accum. Depr.	Net Plant
93			\$ -				\$ -			
94	Jan	2017	\$ -	\$ -	\$ -	\$ -	\$ -	\$ -	\$ -	\$ -
95	Feb	2017	\$ -	\$ -	\$ -	\$ -	\$ -	\$ -	\$ -	\$ -
96	Mar	2017	\$ -	\$ -	\$ -	\$ -	\$ -	\$ -	\$ -	\$ -
97	Apr	2017	\$ -	\$ -	\$ -	\$ -	\$ -	\$ -	\$ -	\$ -
98	May	2017	\$ -	\$ -	\$ -	\$ -	\$ -	\$ -	\$ -	\$ -
99	Jun	2017	\$ -	\$ -	\$ -	\$ -	\$ -	\$ -	\$ -	\$ -
100	Jul	2017	\$ -	\$ -	\$ -	\$ -	\$ -	\$ -	\$ -	\$ -
101	Aug	2017	\$ -	\$ -	\$ -	\$ -	\$ -	\$ -	\$ -	\$ -
102	Sep	2017	\$ -	\$ -	\$ -	\$ -	\$ -	\$ -	\$ -	\$ -
103	Oct	2017	\$ -	\$ -	\$ -	\$ -	\$ -	\$ -	\$ -	\$ -
104	No	2017	\$ -	\$ -	\$ -	\$ -	\$ -	\$ -	\$ -	\$ -
105	Dec	2017	\$ -	\$ -	\$ -	\$ -	\$ -	\$ -	\$ -	\$ -
106	Jan	2018	\$ -	\$ -	\$ -	\$ -	\$ -	\$ -	\$ -	\$ -
107	Feb	2018	\$ -	\$ -	\$ -	\$ -	\$ -	\$ -	\$ -	\$ -
108	Mar	2018	\$ -	\$ -	\$ -	\$ -	\$ -	\$ -	\$ -	\$ -
109	Apr	2018	\$ -	\$ -	\$ -	\$ -	\$ -	\$ -	\$ -	\$ -
110	May	2018	\$ -	\$ -	\$ -	\$ -	\$ -	\$ -	\$ -	\$ -
111	Jun	2018	\$ -	\$ -	\$ -	\$ -	\$ -	\$ -	\$ -	\$ -
112	Jul	2018	\$ -	\$ -	\$ -	\$ -	\$ -	\$ -	\$ -	\$ -
113	Aug	2018	\$ -	\$ -	\$ -	\$ -	\$ -	\$ -	\$ -	\$ -
114	Sep	2018	\$ -	\$ -	\$ -	\$ -	\$ -	\$ -	\$ -	\$ -
115	Oct	2018	\$ -	\$ -	\$ -	\$ -	\$ -	\$ -	\$ -	\$ -
116	Nov	2018	\$ -	\$ -	\$ -	\$ -	\$ -	\$ -	\$ -	\$ -
117	Dec	2018	\$ -	\$ -	\$ -	\$ -	\$ -	\$ -	\$ -	\$ -
118										
119	Total			\$ -				\$ -		
120	13 Mo. Avg.		\$ -		\$ -	\$ -	\$ -		\$ -	\$ -
121										
122										
123			Return due to Incentive TIER Adder			\$ -	Return due to Incentive TIER Adder			\$ -

(A) Special incentive (Depreciation Rate, TIER, or DSC) may be utilized for specific incentive transmission projects if approved by the FERC.

(B) The formula is set up to accommodate an incentive DSC Adder. If FERC grants an ROE adder, it may be converted to a TIER adder using the following formula: TIER Adder = (ROE Adder * Equity Ratio) / Average System Interest Rate, or to a DSC adder using the following formula: DSC Adder = (ROE Adder * Equity ratio) / Average System Debt Service Rate. If FERC grants a different incentive, the formula may need to be modified accordingly.

**Sunflower Electric Power Corporation (SEPC)
Projected Transmission Plant
For the 12 months ended - December 31, 2018**

Summary (Sunflower Owned Facilities)

Total Incentive, Non-Incentive and SPP Plant Total Plant Additions (Excluding Leases)					Projected New Non Incentive Plant								
Mon.	Year	Gross Plant	Depreciation	Accum. Dep.	Plant Additions					Plant in Service	Depreciation Accrual (G)	Accumulated Depreciation	
					RTO Directed (C)	Sponsored (D)	Third Party (E)	Other (F)	Total				
124												0.1405%	
125													
126													
127													
128	(a)	(b)	(c)	(d)	(e)	(f)	(g)	(h)	(i)	(j)	(k)	(l)	(m)
129													
130	Jan	2017	\$ 128,776,640	\$ 180,950	\$ 82,543,694	\$ -	\$ -	\$ -	\$ -	\$ -	\$ 128,776,640	\$ 180,950	\$ 82,543,694
131	Feb	2017	\$ 128,849,075	\$ 180,950	\$ 82,724,643	\$ -	\$ -	\$ -	\$ 72,435	\$ 72,435	\$ 128,849,075	\$ 180,950	\$ 82,724,643
132	Mar	2017	\$ 128,849,075	\$ 181,051	\$ 82,905,694	\$ -	\$ -	\$ -	\$ -	\$ -	\$ 128,849,075	\$ 181,051	\$ 82,905,694
133	Apr	2017	\$ 128,907,794	\$ 181,051	\$ 83,086,746	\$ -	\$ -	\$ -	\$ 58,719	\$ 58,719	\$ 128,907,794	\$ 181,051	\$ 83,086,746
134	May	2017	\$ 129,174,921	\$ 181,134	\$ 83,267,880	\$ -	\$ -	\$ -	\$ 267,127	\$ 267,127	\$ 129,174,921	\$ 181,134	\$ 83,267,880
135	Jun	2017	\$ 129,331,578	\$ 181,509	\$ 83,449,389	\$ -	\$ -	\$ -	\$ 156,657	\$ 156,657	\$ 129,331,578	\$ 181,509	\$ 83,449,389
136	Jul	2017	\$ 130,408,853	\$ 181,729	\$ 83,631,118	\$ -	\$ -	\$ -	\$ 1,077,275	\$ 1,077,275	\$ 130,408,853	\$ 181,729	\$ 83,631,118
137	Aug	2017	\$ 132,888,942	\$ 183,243	\$ 83,814,361	\$ -	\$ -	\$ -	\$ 2,480,089	\$ 2,480,089	\$ 132,888,942	\$ 183,243	\$ 83,814,361
138	Sep	2017	\$ 132,888,942	\$ 186,728	\$ 84,001,089	\$ -	\$ -	\$ -	\$ -	\$ -	\$ 132,888,942	\$ 186,728	\$ 84,001,089
139	Oct	2017	\$ 132,888,942	\$ 186,728	\$ 84,187,817	\$ -	\$ -	\$ -	\$ -	\$ -	\$ 132,888,942	\$ 186,728	\$ 84,187,817
140	Nov	2017	\$ 132,888,942	\$ 186,728	\$ 84,374,545	\$ -	\$ -	\$ -	\$ -	\$ -	\$ 132,888,942	\$ 186,728	\$ 84,374,545
141	Dec	2017	\$ 140,458,613	\$ 186,728	\$ 84,561,273	\$ 3,892,077	\$ -	\$ -	\$ 3,677,594	\$ 7,569,671	\$ 140,458,613	\$ 186,728	\$ 84,561,273
142	Jan	2018	\$ 140,458,613	\$ 197,364	\$ 84,758,637	\$ -	\$ -	\$ -	\$ -	\$ -	\$ 140,458,613	\$ 197,364	\$ 84,758,637
143	Feb	2018	\$ 140,458,613	\$ 197,364	\$ 84,956,002	\$ -	\$ -	\$ -	\$ -	\$ -	\$ 140,458,613	\$ 197,364	\$ 84,956,002
144	Mar	2018	\$ 142,164,979	\$ 197,364	\$ 85,153,366	\$ -	\$ -	\$ -	\$ 1,706,366	\$ 1,706,366	\$ 142,164,979	\$ 197,364	\$ 85,153,366
145	Apr	2018	\$ 147,687,802	\$ 199,762	\$ 85,353,128	\$ 5,522,823	\$ -	\$ -	\$ -	\$ 5,522,823	\$ 147,687,802	\$ 199,762	\$ 85,353,128
146	May	2018	\$ 147,687,802	\$ 207,522	\$ 85,560,651	\$ -	\$ -	\$ -	\$ -	\$ -	\$ 147,687,802	\$ 207,522	\$ 85,560,651
147	Jun	2018	\$ 169,583,835	\$ 207,522	\$ 85,768,173	\$ 21,115,407	\$ -	\$ -	\$ 780,626	\$ 21,896,033	\$ 169,583,835	\$ 207,522	\$ 85,768,173
148	Jul	2018	\$ 169,583,835	\$ 238,290	\$ 86,006,463	\$ -	\$ -	\$ -	\$ -	\$ -	\$ 169,583,835	\$ 238,290	\$ 86,006,463
149	Aug	2018	\$ 169,583,835	\$ 238,290	\$ 86,244,752	\$ -	\$ -	\$ -	\$ -	\$ -	\$ 169,583,835	\$ 238,290	\$ 86,244,752
150	Sep	2018	\$ 171,074,021	\$ 238,290	\$ 86,483,042	\$ -	\$ -	\$ -	\$ 1,490,186	\$ 1,490,186	\$ 171,074,021	\$ 238,290	\$ 86,483,042
151	Oct	2018	\$ 171,074,021	\$ 240,383	\$ 86,723,425	\$ -	\$ -	\$ -	\$ -	\$ -	\$ 171,074,021	\$ 240,383	\$ 86,723,425
152	Nov	2018	\$ 171,074,021	\$ 240,383	\$ 86,963,809	\$ -	\$ -	\$ -	\$ -	\$ -	\$ 171,074,021	\$ 240,383	\$ 86,963,809
153	Dec	2018	\$ 171,074,021	\$ 240,383	\$ 87,204,192	\$ -	\$ -	\$ -	\$ -	\$ -	\$ 171,074,021	\$ 240,383	\$ 87,204,192
154													
155	12 Mon Tot			\$ 2,642,919								\$ 2,642,919	
156	13 Mon Avg	\$ 157,843,385		\$ 85,825,916							\$ 157,843,385		\$ 85,825,916

Notes:

- (C) See WP P-4 (Proj. RTO Directed).
- (D) See WP P-5 (Sponsored Projects).
- (E) See WP P-6 (Third Party Projects).
- (F) Other transmission projects, not included in the Special Project categories.
- (G) See WP A-5 (Act Depreciation Rate).

Sunflower Electric Power Corporation (SEPC)
Projected Transmission Plant
For the 12 months ended - December 31, 2018

Capital Leases

		Plant-in-Service as of 12/31/2016			New Non-RTO Facilities			New RTO Facilities			Total Capital Leases		
		Gross Plant	Equiv. Acuum. Amortization	Net Plant	Gross Plant	Equiv. Acuum. Amortization	Net Plant	Gross Plant	Equiv. Acuum. Amortization	Net Plant	Gross Plant	Equiv. Acuum. Amortization	Net Plant
157													
158													
159	Mon. Year	(c)	(d)	(e)	(f)	(g)	(h)	(i)	(j)	(k)	(l)	(m)	(n)
160	(a) (b)	(c)	(d)	(e)	(f)	(g)	(h)	(i)	(j)	(k)	(l)	(m)	(n)
161													
162	Jan 2017	\$ 26,831,837	\$ 8,209,632	\$ 18,622,205	\$ -	\$ -	\$ -	\$ -	\$ -	\$ -	#REF!	\$ 8,209,632	\$ 18,622,205
163	Feb 2017	\$ 26,831,837	\$ 8,312,017	\$ 18,519,820	\$ -	\$ -	\$ -	\$ -	\$ -	\$ -	\$ 26,831,837	\$ 8,312,017	\$ 18,519,820
164	Mar 2017	\$ 26,831,837	\$ 8,414,402	\$ 18,417,435	\$ -	\$ -	\$ -	\$ -	\$ -	\$ -	\$ 26,831,837	\$ 8,414,402	\$ 18,417,435
165	Apr 2017	\$ 26,831,837	\$ 8,516,787	\$ 18,315,050	\$ -	\$ -	\$ -	\$ -	\$ -	\$ -	\$ 26,831,837	\$ 8,516,787	\$ 18,315,050
166	May 2017	\$ 26,831,837	\$ 8,619,172	\$ 18,212,665	\$ -	\$ -	\$ -	\$ -	\$ -	\$ -	\$ 26,831,837	\$ 8,619,172	\$ 18,212,665
167	Jun 2017	\$ 26,831,837	\$ 8,721,557	\$ 18,110,280	\$ -	\$ -	\$ -	\$ -	\$ -	\$ -	\$ 26,831,837	\$ 8,721,557	\$ 18,110,280
168	Jul 2017	\$ 26,831,837	\$ 8,823,942	\$ 18,007,895	\$ -	\$ -	\$ -	\$ -	\$ -	\$ -	\$ 26,831,837	\$ 8,823,942	\$ 18,007,895
169	Aug 2017	\$ 26,831,837	\$ 8,926,327	\$ 17,905,510	\$ -	\$ -	\$ -	\$ -	\$ -	\$ -	\$ 26,831,837	\$ 8,926,327	\$ 17,905,510
170	Sep 2017	\$ 26,831,837	\$ 9,028,712	\$ 17,803,125	\$ -	\$ -	\$ -	\$ -	\$ -	\$ -	\$ 26,831,837	\$ 9,028,712	\$ 17,803,125
171	Oct 2017	\$ 26,831,837	\$ 9,131,097	\$ 17,700,740	\$ -	\$ -	\$ -	\$ -	\$ -	\$ -	\$ 26,831,837	\$ 9,131,097	\$ 17,700,740
172	Nov 2017	\$ 26,831,837	\$ 9,233,482	\$ 17,598,355	\$ -	\$ -	\$ -	\$ -	\$ -	\$ -	\$ 26,831,837	\$ 9,233,482	\$ 17,598,355
173	Dec 2017	\$ 26,831,837	\$ 9,335,867	\$ 17,495,970	\$ -	\$ -	\$ -	\$ -	\$ -	\$ -	\$ 26,831,837	\$ 9,335,867	\$ 17,495,970
174	Jan 2018	\$ 26,831,837	\$ 9,432,716	\$ 17,399,121	\$ -	\$ -	\$ -	\$ -	\$ -	\$ -	\$ 26,831,837	\$ 9,432,716	\$ 17,399,121
175	Feb 2018	\$ 26,831,837	\$ 9,529,565	\$ 17,302,272	\$ -	\$ -	\$ -	\$ -	\$ -	\$ -	\$ 26,831,837	\$ 9,529,565	\$ 17,302,272
176	Mar 2018	\$ 26,831,837	\$ 9,626,414	\$ 17,205,423	\$ -	\$ -	\$ -	\$ -	\$ -	\$ -	\$ 26,831,837	\$ 9,626,414	\$ 17,205,423
177	Apr 2018	\$ 26,831,837	\$ 9,723,263	\$ 17,108,574	\$ -	\$ -	\$ -	\$ -	\$ -	\$ -	\$ 26,831,837	\$ 9,723,263	\$ 17,108,574
178	May 2018	\$ 26,831,837	\$ 9,820,112	\$ 17,011,725	\$ -	\$ -	\$ -	\$ -	\$ -	\$ -	\$ 26,831,837	\$ 9,820,112	\$ 17,011,725
179	Jun 2018	\$ 26,831,837	\$ 9,916,961	\$ 16,914,876	\$ -	\$ -	\$ -	\$ -	\$ -	\$ -	\$ 26,831,837	\$ 9,916,961	\$ 16,914,876
180	Jul 2018	\$ 26,831,837	\$ 10,013,810	\$ 16,818,027	\$ -	\$ -	\$ -	\$ -	\$ -	\$ -	\$ 26,831,837	\$ 10,013,810	\$ 16,818,027
181	Aug 2018	\$ 26,831,837	\$ 10,110,659	\$ 16,721,178	\$ -	\$ -	\$ -	\$ -	\$ -	\$ -	\$ 26,831,837	\$ 10,110,659	\$ 16,721,178
182	Sep 2018	\$ 26,831,837	\$ 10,207,508	\$ 16,624,329	\$ -	\$ -	\$ -	\$ -	\$ -	\$ -	\$ 26,831,837	\$ 10,207,508	\$ 16,624,329
183	Oct 2018	\$ 26,831,837	\$ 10,304,357	\$ 16,527,480	\$ -	\$ -	\$ -	\$ -	\$ -	\$ -	\$ 26,831,837	\$ 10,304,357	\$ 16,527,480
184	Nov 2018	\$ 26,831,837	\$ 10,401,206	\$ 16,430,631	\$ -	\$ -	\$ -	\$ -	\$ -	\$ -	\$ 26,831,837	\$ 10,401,206	\$ 16,430,631
185	Dec 2018	\$ 26,831,837	\$ 10,498,055	\$ 16,333,782	\$ -	\$ -	\$ -	\$ -	\$ -	\$ -	\$ 26,831,837	\$ 10,498,055	\$ 16,333,782
186													
187	13 Mon Avg			\$ 16,914,876			\$ -			\$ -	\$ 26,831,837	\$ 9,916,961	\$ 16,914,876

Note: Depreciation/amortization is not actual recorded for capital leased facilities. Instead, Plant-in-Service is reduced as a portion of the lease payments are used to reduce the principle amount. The above treatment is equivalent to the accounting treatment intended to develop the appropriate Net Plant values to use in allocating O&M and other expenses.

**Sunflower Electric Power Corporation (SEPC)
Projected Transmission Plant
For the 12 months ended - December 31, 2018**

Operating Leases

		Plant-in-Service as of 12/31/2016			New Non-RTO Facilities			New RTO Facilities			Total Operating Leases		
		Gross Plant	Equiv. Acuum. Amortization	Net Plant	Gross Plant	Equiv. Acuum. Amortization	Net Plant	Gross Plant	Equiv. Acuum. Amortization	Net Plant	Gross Plant	Equiv. Acuum. Amortization	Net Plant
Mon.	Year	(c)	(d)	(e)	(f)	(g)	(h)	(i)	(j)	(k)	(l)	(m)	(n)
193	Jan 2017	\$ 17,653,096	\$ 1,147,736	\$ 16,505,360	\$ -	\$ -	\$ -	\$ 12,929,229	\$ -	\$ 12,929,229	\$ 30,582,325	\$ 1,147,736	\$ 29,434,589
194	Feb 2017	\$ 17,653,096	\$ 1,169,536	\$ 16,483,560	\$ -	\$ -	\$ -	\$ 12,929,229	\$ -	\$ 12,929,229	\$ 30,582,325	\$ 1,169,536	\$ 29,412,789
195	Mar 2017	\$ 17,653,096	\$ 1,191,336	\$ 16,461,761	\$ -	\$ -	\$ -	\$ 12,929,229	\$ -	\$ 12,929,229	\$ 30,582,325	\$ 1,191,336	\$ 29,390,990
196	Apr 2017	\$ 17,653,096	\$ 1,213,135	\$ 16,439,961	\$ -	\$ -	\$ -	\$ 12,929,229	\$ -	\$ 12,929,229	\$ 30,582,325	\$ 1,213,135	\$ 29,369,190
197	May 2017	\$ 17,653,096	\$ 1,234,935	\$ 16,418,161	\$ -	\$ -	\$ -	\$ 12,929,229	\$ -	\$ 12,929,229	\$ 30,582,325	\$ 1,234,935	\$ 29,347,390
198	Jun 2017	\$ 17,653,096	\$ 1,256,735	\$ 16,396,361	\$ -	\$ -	\$ -	\$ 12,929,229	\$ -	\$ 12,929,229	\$ 30,582,325	\$ 1,256,735	\$ 29,325,590
199	Jul 2017	\$ 30,582,325	\$ 1,296,904	\$ 29,285,421	\$ -	\$ -	\$ -	\$ 12,929,229	\$ 16,885	\$ 12,912,344	\$ 43,511,554	\$ 1,313,789	\$ 42,197,765
200	Aug 2017	\$ 30,582,325	\$ 1,337,072	\$ 29,245,253	\$ -	\$ -	\$ -	\$ 12,929,229	\$ 16,885	\$ 12,912,344	\$ 43,511,554	\$ 1,353,957	\$ 42,157,597
201	Sep 2017	\$ 30,582,325	\$ 1,377,241	\$ 29,205,084	\$ -	\$ -	\$ -	\$ 12,929,229	\$ 16,885	\$ 12,912,344	\$ 43,511,554	\$ 1,394,126	\$ 42,117,428
202	Oct 2017	\$ 30,582,325	\$ 1,417,409	\$ 29,164,916	\$ -	\$ -	\$ -	\$ 12,929,229	\$ 16,885	\$ 12,912,344	\$ 43,511,554	\$ 1,434,294	\$ 42,077,260
203	Nov 2017	\$ 30,582,325	\$ 1,457,578	\$ 29,124,747	\$ -	\$ -	\$ -	\$ 12,929,229	\$ 16,885	\$ 12,912,344	\$ 43,511,554	\$ 1,474,463	\$ 42,037,091
204	Dec 2017	\$ 30,582,325	\$ 1,497,747	\$ 29,084,579	\$ -	\$ -	\$ -	\$ 12,929,229	\$ 16,885	\$ 12,912,344	\$ 43,511,554	\$ 1,514,632	\$ 41,996,922
205	Jan 2018	\$ 30,582,325	\$ 1,537,915	\$ 29,044,410	\$ -	\$ -	\$ -	\$ 12,929,229	\$ 16,885	\$ 12,912,344	\$ 43,511,554	\$ 1,554,800	\$ 41,956,754
206	Feb 2018	\$ 30,582,325	\$ 1,578,084	\$ 29,004,241	\$ -	\$ -	\$ -	\$ 12,929,229	\$ 16,885	\$ 12,912,344	\$ 43,511,554	\$ 1,594,969	\$ 41,916,585
207	Mar 2018	\$ 30,582,325	\$ 1,618,252	\$ 28,964,073	\$ -	\$ -	\$ -	\$ 12,929,229	\$ 16,885	\$ 12,912,344	\$ 43,511,554	\$ 1,635,137	\$ 41,876,417
208	Apr 2018	\$ 30,582,325	\$ 1,658,421	\$ 28,923,904	\$ -	\$ -	\$ -	\$ 12,929,229	\$ 16,885	\$ 12,912,344	\$ 43,511,554	\$ 1,675,306	\$ 41,836,248
209	May 2018	\$ 30,582,325	\$ 1,698,589	\$ 28,883,736	\$ -	\$ -	\$ -	\$ 12,929,229	\$ 16,885	\$ 12,912,344	\$ 43,511,554	\$ 1,715,475	\$ 41,796,080
210	Jun 2018	\$ 30,582,325	\$ 1,738,758	\$ 28,843,567	\$ -	\$ -	\$ -	\$ 12,929,229	\$ 16,885	\$ 12,912,344	\$ 43,511,554	\$ 1,755,643	\$ 41,755,911
211	Jul 2018	\$ 30,582,325	\$ 1,781,316	\$ 28,801,009	\$ -	\$ -	\$ -	\$ 12,929,229	\$ 17,689	\$ 12,911,540	\$ 43,511,554	\$ 1,799,005	\$ 41,712,549
212	Aug 2018	\$ 30,582,325	\$ 1,823,873	\$ 28,758,452	\$ -	\$ -	\$ -	\$ 12,929,229	\$ 17,689	\$ 12,911,540	\$ 43,511,554	\$ 1,841,563	\$ 41,669,991
213	Sep 2018	\$ 30,582,325	\$ 1,866,431	\$ 28,715,894	\$ -	\$ -	\$ -	\$ 12,929,229	\$ 17,689	\$ 12,911,540	\$ 43,511,554	\$ 1,884,120	\$ 41,627,434
214	Oct 2018	\$ 30,582,325	\$ 1,908,988	\$ 28,673,337	\$ -	\$ -	\$ -	\$ 12,929,229	\$ 17,689	\$ 12,911,540	\$ 43,511,554	\$ 1,926,678	\$ 41,584,876
215	Nov 2018	\$ 30,582,325	\$ 1,951,546	\$ 28,630,779	\$ -	\$ -	\$ -	\$ 12,929,229	\$ 17,689	\$ 12,911,540	\$ 43,511,554	\$ 1,969,235	\$ 41,542,319
216	Dec 2018	\$ 30,582,325	\$ 1,994,104	\$ 28,588,222	\$ -	\$ -	\$ -	\$ 12,929,229	\$ 17,689	\$ 12,911,540	\$ 43,511,554	\$ 2,011,793	\$ 41,499,761
217													
218	13 Mon Avg			\$ 28,839,708			\$ -			\$ 12,911,973	\$ 43,511,554	\$ 1,759,873	\$ 41,751,681

Note: Plant investment is not actual recorded for operating leased facilities. The above treatment is equivalent to the accounting treatment intended to develop the appropriate proxy Net Plant values to use in allocating O&M and other expenses.

Sunflower Electric Power Corporation (SEPC)
Projected Expenses and Revenue Credits
For the 12 months ended - December 31, 2018

Line	Description	Source	(3) 2016 Actual Costs	(4)	(5) 2018 Projected Costs (Ratio * Proj. Net Plant)
1	Net Plant in Service (Excludes Capital and Operating Leases)	Actual Gross Rev, Pg. 1, L22, Col 6 & Projected Gross Rev, Pg 1, L21, Col. 6	\$ 46,661,255		\$ 72,017,469
2	Plus: Net Plant Equivalent for Capital Leases (Note D)	A-12 , Pg. 1, L23 & P-1, Pg. 5, L187	19,312,562		16,914,876
3	Plus: Net Plant Equivalent for Operating Leases (Note D)	A-12, Pg. 1, L28 & P-1, Pg.6, L218	16,655,715		41,751,681
4	Less: Net Plant Excluded for O&M, Other Taxes and Gen. Plant	Note A	-		-
5	Adjusted Net Plant for O&M and Other Taxes	L1 + L2 + L3 - L4	\$ 82,629,533		\$ 130,684,026
6	Ratio Projected Net Plant to Actual Net Plant			CALC RATIO =	1.5816
7	CAP on Ratio	Input		CAP =	1.1000
8	Capped Ratio Used to Project Expenses	Lesser of L6 or L7		CAPPED RATIO	1.1000
9	Operation and Maintenance Expenses				
10	Transmission	Actual Gross Rev, Pg. 2, L60	\$ 42,865,398	x CAPPED RATIO	\$ 47,151,938
11	Less: Account 565	Actual Gross Rev, Pg. 2, L61	28,002,102	x CAPPED RATIO	30,802,312
12	Less: Transmission Leases & Facility Charges	Actual Gross Rev, Pg. 2, L62	4,618,866	x CAPPED RATIO	5,080,753
13	Less Schedule 1 Rev. Req.	Actual Gross Rev, Pg. 2, L63	1,385,295	x CAPPED RATIO	1,523,825
14	Plus: Projected Transmission Leases & Facility Charges	See Note B			5,512,930
15	A&G -Adjusted per WP A-11	Actual Gross Rev, Pg. 2, L65	14,387,580	x CAPPED RATIO	15,826,338
16	Plus: Safety Advertising	Actual Gross Rev, Pg. 2, L66	-	x CAPPED RATIO	-
17	Plus Association Dues Directly Related to Transmission	Actual Gross Rev, Pg. 2, L67	-	x CAPPED RATIO	-
18	Plus: Advertising -Transmission	Actual Gross Rev, Pg. 2, L68	-	x CAPPED RATIO	-
19	Plus: Research -Transmission	Actual Gross Rev, Pg. 2, L69	-	x CAPPED RATIO	-
20	Plus: Regulatory Exp -Transmission	Actual Gross Rev, Pg. 2, L70	24,400	x CAPPED RATIO	26,840
21	Plus: Corporate Visibility -Transmission	Actual Gross Rev, Pg. 2, L71	-	x CAPPED RATIO	-
22	Projected O&M	L10 - Sum(L11:L13) + L14 + L15 + Sum(L16:L21)	\$ 23,271,115		\$ 31,111,156
23	Other Taxes				
24	LABOR RELATED				
25	Payroll	Actual Gross Rev, Pg. 2, L87	\$ -	x CAPPED RATIO	\$ -
26	Highway and vehicle	Actual Gross Rev, Pg. 2, L88	-	x CAPPED RATIO	-
27	PLANT RELATED				
28	Property (Note P)	Actual Gross Rev, Pg. 2, L90	-	x CAPPED RATIO	-
29	Gross Receipts	Actual Gross Rev, Pg. 2, L91	-	x CAPPED RATIO	-
30	Other	Actual Gross Rev, Pg. 2, L92	386	x CAPPED RATIO	425
31	Projected Other Taxes	Sum (L25:L30)	\$ 386		\$ 425
32					
33	Revenue Credits				
34	Total Sch. 11 Revenue Received in 2016			WP A-1 (Act Rev Credits), L34	\$ 7,216,301
35					
36	Net Projected ATRR for Projects Completed as of 12/31/2018 for which Revenue was Received in 2016				
37	Johnson to Pioneer 115kV Line				\$ 438,365
38	Johnson Corner Capacitor Bank #1				\$ 52,607
39	Johnson Corner Capacitor Bank #2				\$ 38,197
40	Holcomb to Fletcher 115kV Line (Wheatland)				\$ 651,391
41	Holcomb to Plymell 115kV (MKEC)				\$ 531,778
42	Plymell to Pioneer Tap 115kV (MKEC)				\$ 675,822
43	Mingo Transformer/Terminal Upgrades				\$ 2,845,633
44	Total Net Projected ATRR for Projects Completed as of 12/31/2018		Sum(L37:L43)		\$ 5,233,793
45					
46	Net Schedule 11 Revenue to be Applied as a Credit to Zonal ATRR in 2018		L34 - L44 if positive		\$ 1,982,508
47	Adjustment to Revenue Credits Applied to Zonal Revenue Requirements.		Note C		\$ 3,888,825
48	Total Revenue Credits Applied to Zonal Revenue Requirements				\$ 5,871,333

Notes:

- A For some Special Projects, constructed on behalf of others, Sunflower may contract with the other party to operate and maintain the subject facilities. Under such circumstances, the O&M and associated labor expenses are not recorded on Sunflower's books. No such projects are projected through 2014.
- B Lease payments for 2016 (actual) and 2018 (projected) are shown below:

	Annualized	
	2016	2018
Midwest Energy	\$ -	\$ -
Pioneer	1,337,523	1,337,523
Western	-	-
Wheatland	1,356,582	1,194,906
Mid-Kansas (Rhoades to Phillipsburg 115 kV line)	1,097,530	1,097,530
Mid-Kansas (Holcomb to Plymell 115 kV line)	355,700	355,700
Mid-Kansas (Plymell to Pioneer Tap 115 kV line)	452,047	452,047
Mid-Kansas (Mingo Transformer)	-	1,075,224
Total	\$ 4,599,382	\$ 5,512,930

- C For the initial filing, use the value from the Actual Test Year. However, if major known and measurable changes are expected, provide a separate workpaper to support any adjustments
- D Operating and Capital Leases are only to be included here if Sunflower is responsible for the O&M expense

**Sunflower Electric Power Corporation (SEPC)
Projected Transmission Network Load
For the 12 months ended - December 31, 2017**

Line No.	a	b	c	d	e	f
	Month	Monthly Transmission Network Load as Percentage of the Average Total Network Load of January thru August. (Worksheet A-2)	Average Monthly Transmission Network Load for January thru August (col e, line 2 thru line 9)	Estimated Monthly Transmission Network Load for September thru December (b X c)	Actual Load for January through August	Projected Transmission Network Load
1	January				331.35	331.35
3	February				316.71	316.71
4	March				324.67	324.67
5	April				336.87	336.87
6	May				348.72	348.72
7	June				492.80	492.80
8	July				530.59	530.59
9	August				453.51	453.51
10	September	103.24%	391.90	404.59		404.59
11	October	87.62%	391.90	343.40		343.40
12	November	77.72%	391.90	304.58		304.58
13	December	83.16%	391.90	325.91		325.91
14	Total					4,513.68
15	12-CP					376.14

Note: **Column b** is the monthly transmission network load for September, October, November and December as a percentage of the average of the monthly transmission network load values for January through August, based on monthly load values in Worksheet A-2.

Column c is average (January thru August) of monthly transmission network load in column e.

Column f contains actual load values for January-August and projected load values for September - December.

**Sunflower Electric Power Corporation (SEPC)
Projected Transmission Plant Related Projects -RTO Directed Projects (B & C)
For the 12 months ended - December 31, 2018**

1 Total Base Plan Projects (Sunflower Owned)			Buckner - Spearville 345 kV Ckt 1 Terminal Upgrades			Walkemeyer Tap - Walkemeyer 345/115 kV			Ellsworth 115 kV Cap Bank					
			Project: 1			Project: 2			Project: 3					
2	SPP Proj. ID		30916			SPP Proj. ID		30912			SPP Proj. ID		30917	
3	Depr. Rate:		0.1405% (A)			Depr. Rate:		0.1405% (A)			Depr. Rate:		0.1405% (A)	
4	Begin Plant in Serv.		\$ -			Begin Plant in Serv.		\$ -			Begin Plant in Serv.		\$ -	
5	Begin. Acc. Depr:		\$ -			Begin. Acc. Depr:		\$ -			Begin. Acc. Depr:		\$ -	
6	Begin. Year-Mo.:		DEC-17			Begin. Year-Mo.:		JUN-18			Begin. Year-Mo.:		JUN-18	
7	Mon.	Year	Total			Gross Plant	Accm. Depr.	Net Plant	Gross Plant	Accm. Depr.	Net Plant	Gross Plant	Accm. Depr.	Net Plant
8						\$ -			\$ -			\$ -		
9	Jan	2017	\$ -	\$ -	\$ -	\$ -	\$ -	\$ -	\$ -	\$ -	\$ -	\$ -	\$ -	\$ -
10	Feb	2017	\$ -	\$ -	\$ -	\$ -	\$ -	\$ -	\$ -	\$ -	\$ -	\$ -	\$ -	\$ -
11	Mar	2017	\$ -	\$ -	\$ -	\$ -	\$ -	\$ -	\$ -	\$ -	\$ -	\$ -	\$ -	\$ -
12	Apr	2017	\$ -	\$ -	\$ -	\$ -	\$ -	\$ -	\$ -	\$ -	\$ -	\$ -	\$ -	\$ -
13	May	2017	\$ -	\$ -	\$ -	\$ -	\$ -	\$ -	\$ -	\$ -	\$ -	\$ -	\$ -	\$ -
14	Jun	2017	\$ -	\$ -	\$ -	\$ -	\$ -	\$ -	\$ -	\$ -	\$ -	\$ -	\$ -	\$ -
15	Jul	2017	\$ -	\$ -	\$ -	\$ -	\$ -	\$ -	\$ -	\$ -	\$ -	\$ -	\$ -	\$ -
16	Aug	2017	\$ -	\$ -	\$ -	\$ -	\$ -	\$ -	\$ -	\$ -	\$ -	\$ -	\$ -	\$ -
17	Sep	2017	\$ -	\$ -	\$ -	\$ -	\$ -	\$ -	\$ -	\$ -	\$ -	\$ -	\$ -	\$ -
18	Oct	2017	\$ -	\$ -	\$ -	\$ -	\$ -	\$ -	\$ -	\$ -	\$ -	\$ -	\$ -	\$ -
19	No	2017	\$ -	\$ -	\$ -	\$ -	\$ -	\$ -	\$ -	\$ -	\$ -	\$ -	\$ -	\$ -
20	Dec	2017	\$ 3,892,077	\$ -	\$ 3,892,077	\$ 3,892,077	\$ -	\$ 3,892,077	\$ -	\$ -	\$ -	\$ -	\$ -	\$ -
21	Jan	2018	\$ 3,892,077	\$ 5,469	\$ 3,886,608	\$ 3,892,077	\$ 5,469	\$ 3,886,608	\$ -	\$ -	\$ -	\$ -	\$ -	\$ -
22	Feb	2018	\$ 3,892,077	\$ 10,938	\$ 3,881,139	\$ 3,892,077	\$ 10,938	\$ 3,881,139	\$ -	\$ -	\$ -	\$ -	\$ -	\$ -
23	Mar	2018	\$ 3,892,077	\$ 16,407	\$ 3,875,670	\$ 3,892,077	\$ 16,407	\$ 3,875,670	\$ -	\$ -	\$ -	\$ -	\$ -	\$ -
24	Apr	2018	\$ 9,414,900	\$ 21,876	\$ 9,393,024	\$ 3,892,077	\$ 21,876	\$ 3,870,201	\$ -	\$ -	\$ -	\$ -	\$ -	\$ -
25	May	2018	\$ 9,414,900	\$ 35,105	\$ 9,379,795	\$ 3,892,077	\$ 27,345	\$ 3,864,732	\$ -	\$ -	\$ -	\$ -	\$ -	\$ -
26	Jun	2018	\$ 30,530,307	\$ 48,334	\$ 30,481,973	\$ 3,892,077	\$ 32,814	\$ 3,859,263	\$ 18,132,011	\$ -	#####	\$ 2,983,396	\$ -	\$ 2,983,396
27	Jul	2018	\$ 30,530,307	\$ 91,233	\$ 30,439,074	\$ 3,892,077	\$ 38,283	\$ 3,853,794	\$ 18,132,011	\$ 25,478	#####	\$ 2,983,396	\$ 4,192	\$ 2,979,204
28	Aug	2018	\$ 30,530,307	\$ 134,132	\$ 30,396,175	\$ 3,892,077	\$ 43,752	\$ 3,848,325	\$ 18,132,011	\$ 50,956	#####	\$ 2,983,396	\$ 8,384	\$ 2,975,012
29	Sep	2018	\$ 30,530,307	\$ 177,031	\$ 30,353,276	\$ 3,892,077	\$ 49,221	\$ 3,842,856	\$ 18,132,011	\$ 76,434	#####	\$ 2,983,396	\$ 12,576	\$ 2,970,820
30	Oct	2018	\$ 30,530,307	\$ 219,930	\$ 30,310,377	\$ 3,892,077	\$ 54,690	\$ 3,837,387	\$ 18,132,011	\$ 101,912	#####	\$ 2,983,396	\$ 16,768	\$ 2,966,628
31	Nov	2018	\$ 30,530,307	\$ 262,829	\$ 30,267,478	\$ 3,892,077	\$ 60,159	\$ 3,831,918	\$ 18,132,011	\$ 127,390	#####	\$ 2,983,396	\$ 20,960	\$ 2,962,436
32	Dec	2018	\$ 30,530,307	\$ 305,728	\$ 30,224,579	\$ 3,892,077	\$ 65,628	\$ 3,826,449	\$ 18,132,011	\$ 152,868	#####	\$ 2,983,396	\$ 25,152	\$ 2,958,244
33														
34	13 Mon Avg		\$ 19,085,404	\$ 102,232	\$ 18,983,173	\$ 3,892,077	\$ 32,814	\$ 3,859,263	\$ 9,763,391	\$ 41,157	\$ 9,722,234	\$ 1,606,444	\$ 6,772	\$ 1,599,672
35	12 Mon Depr Exp			\$ 305,728			\$ 65,628			\$ 152,868			\$ 25,152	

Notes:

(A) See WP A-5 (Act Depreciation.Rate).

(B) P-4 projects should be included in total projected transmission projects for P-1

(C) Projects should not be listed until the first year they are expected to be in service. Do not duplicate projects listed in A-7 (Act.RTO Directed Proj).

**Sunflower Electric Power Corporation (SEPC)
Projected Transmission Plant Related Projects -RTO Directed Projects (B & C)
For the 12 months ended - December 31, 2018**

Base Plan Projects (Sunflower Owned) (cont'd)			Ingalls 115 kV Cap Bank								
			Project: 4			Project: 5			Project: 6		
Month	Year		Gross Plant	Accm. Depr.	Net Plant	Gross Plant	Accm. Depr.	Net Plant	Gross Plant	Accm. Depr.	Net Plant
36											
37											
38											
39											
40											
41											
42											
43			\$ -			\$ -			\$ -		
44	Jan	2017	\$ -	\$ -	\$ -	\$ -	\$ -	\$ -	\$ -	\$ -	\$ -
45	Feb	2017	\$ -	\$ -	\$ -	\$ -	\$ -	\$ -	\$ -	\$ -	\$ -
46	Mar	2017	\$ -	\$ -	\$ -	\$ -	\$ -	\$ -	\$ -	\$ -	\$ -
47	Apr	2017	\$ -	\$ -	\$ -	\$ -	\$ -	\$ -	\$ -	\$ -	\$ -
48	May	2017	\$ -	\$ -	\$ -	\$ -	\$ -	\$ -	\$ -	\$ -	\$ -
49	Jun	2017	\$ -	\$ -	\$ -	\$ -	\$ -	\$ -	\$ -	\$ -	\$ -
50	Jul	2017	\$ -	\$ -	\$ -	\$ -	\$ -	\$ -	\$ -	\$ -	\$ -
51	Aug	2017	\$ -	\$ -	\$ -	\$ -	\$ -	\$ -	\$ -	\$ -	\$ -
52	Sep	2017	\$ -	\$ -	\$ -	\$ -	\$ -	\$ -	\$ -	\$ -	\$ -
53	Oct	2017	\$ -	\$ -	\$ -	\$ -	\$ -	\$ -	\$ -	\$ -	\$ -
54	No	2017	\$ -	\$ -	\$ -	\$ -	\$ -	\$ -	\$ -	\$ -	\$ -
55	Dec	2017	\$ -	\$ -	\$ -	\$ -	\$ -	\$ -	\$ -	\$ -	\$ -
56	Jan	2018	\$ -	\$ -	\$ -	\$ -	\$ -	\$ -	\$ -	\$ -	\$ -
57	Feb	2018	\$ -	\$ -	\$ -	\$ -	\$ -	\$ -	\$ -	\$ -	\$ -
58	Mar	2018	\$ -	\$ -	\$ -	\$ -	\$ -	\$ -	\$ -	\$ -	\$ -
59	Apr	2018	\$ 5,522,823	\$ -	\$ 5,522,823	\$ -	\$ -	\$ -	\$ -	\$ -	\$ -
60	May	2018	\$ 5,522,823	\$ 7,760	\$ 5,515,063	\$ -	\$ -	\$ -	\$ -	\$ -	\$ -
61	Jun	2018	\$ 5,522,823	\$ 15,520	\$ 5,507,303	\$ -	\$ -	\$ -	\$ -	\$ -	\$ -
62	Jul	2018	\$ 5,522,823	\$ 23,280	\$ 5,499,543	\$ -	\$ -	\$ -	\$ -	\$ -	\$ -
63	Aug	2018	\$ 5,522,823	\$ 31,040	\$ 5,491,783	\$ -	\$ -	\$ -	\$ -	\$ -	\$ -
64	Sep	2018	\$ 5,522,823	\$ 38,800	\$ 5,484,023	\$ -	\$ -	\$ -	\$ -	\$ -	\$ -
65	Oct	2018	\$ 5,522,823	\$ 46,560	\$ 5,476,263	\$ -	\$ -	\$ -	\$ -	\$ -	\$ -
66	No	2018	\$ 5,522,823	\$ 54,320	\$ 5,468,503	\$ -	\$ -	\$ -	\$ -	\$ -	\$ -
67	Dec	2018	\$ 5,522,823	\$ 62,080	\$ 5,460,743	\$ -	\$ -	\$ -	\$ -	\$ -	\$ -
68											
69	13 Mon Avg		\$ 3,823,493	\$ 21,489	\$ 3,802,004	\$ -	\$ -	\$ -	\$ -	\$ -	\$ -
70	12 Mon Depr Exp		12 Mon Depr Exp	\$ 62,080		12 Mon Depr Exp	\$ -		12 Mon Depr Exp	\$ -	

Notes:

(A) See WP A-5 (Act Depreciation.Rate).

(B) P-4 projects should be included in total projected transmission projects for P-1

(C) Projects should not be listed until the first year they are expected to be in service unless there is a CWIP return incentive. Do not duplicate projects listed in A-7 (Act. RTO Proj).

**Sunflower Electric Power Corporation (SEPC)
Projected Transmission Plant Related Projects -RTO Directed Projects (B & C)
For the 12 months ended - December 31, 2018**

71 Total Base Plan Projects (Capital Leases)					Project: 1			Project: 2			Project: 3		
72	SPP Proj. ID				SPP Proj. ID			SPP Proj. ID			SPP Proj. ID		
73	Sum of Monthly Lease Payments 2018				Sum of Monthly Lease Payments 2018			Sum of Monthly Lease Payments 2018			Sum of Monthly Lease Payments 2018		
74	Begin Plant in Serv. \$ -				Begin Plant in Serv. \$ -			Begin Plant in Serv. \$ -			Begin Plant in Serv. \$ -		
75	Begin. Acc. Amort: \$ -				Begin. Acc. Amort: \$ -			Begin. Acc. Amort: \$ -			Begin. Acc. Amort: \$ -		
76	Begin. Year-Mo.:				Begin. Year-Mo.:			Begin. Year-Mo.:			Begin. Year-Mo.:		
77	Mon.	Year	Total		Gross Plant	Accm. Amort.	Net Plant	Gross Plant	Accm. Amort.	Net Plant	Gross Plant	Accm. Amort.	Net Plant
78													
79	Jan	2017	\$ -	\$ -	\$ -	\$ -	\$ -	\$ -	\$ -	\$ -	\$ -	\$ -	\$ -
80	Feb	2017	\$ -	\$ -	\$ -	\$ -	\$ -	\$ -	\$ -	\$ -	\$ -	\$ -	\$ -
81	Mar	2017	\$ -	\$ -	\$ -	\$ -	\$ -	\$ -	\$ -	\$ -	\$ -	\$ -	\$ -
82	Apr	2017	\$ -	\$ -	\$ -	\$ -	\$ -	\$ -	\$ -	\$ -	\$ -	\$ -	\$ -
83	May	2017	\$ -	\$ -	\$ -	\$ -	\$ -	\$ -	\$ -	\$ -	\$ -	\$ -	\$ -
84	Jun	2017	\$ -	\$ -	\$ -	\$ -	\$ -	\$ -	\$ -	\$ -	\$ -	\$ -	\$ -
85	Jul	2017	\$ -	\$ -	\$ -	\$ -	\$ -	\$ -	\$ -	\$ -	\$ -	\$ -	\$ -
86	Aug	2017	\$ -	\$ -	\$ -	\$ -	\$ -	\$ -	\$ -	\$ -	\$ -	\$ -	\$ -
87	Sep	2017	\$ -	\$ -	\$ -	\$ -	\$ -	\$ -	\$ -	\$ -	\$ -	\$ -	\$ -
88	Oct	2017	\$ -	\$ -	\$ -	\$ -	\$ -	\$ -	\$ -	\$ -	\$ -	\$ -	\$ -
89	No	2017	\$ -	\$ -	\$ -	\$ -	\$ -	\$ -	\$ -	\$ -	\$ -	\$ -	\$ -
90	Dec	2017	\$ -	\$ -	\$ -	\$ -	\$ -	\$ -	\$ -	\$ -	\$ -	\$ -	\$ -
91	Jan	2018	\$ -	\$ -	\$ -	\$ -	\$ -	\$ -	\$ -	\$ -	\$ -	\$ -	\$ -
92	Feb	2018	\$ -	\$ -	\$ -	\$ -	\$ -	\$ -	\$ -	\$ -	\$ -	\$ -	\$ -
93	Mar	2018	\$ -	\$ -	\$ -	\$ -	\$ -	\$ -	\$ -	\$ -	\$ -	\$ -	\$ -
94	Apr	2018	\$ -	\$ -	\$ -	\$ -	\$ -	\$ -	\$ -	\$ -	\$ -	\$ -	\$ -
95	May	2018	\$ -	\$ -	\$ -	\$ -	\$ -	\$ -	\$ -	\$ -	\$ -	\$ -	\$ -
96	Jun	2018	\$ -	\$ -	\$ -	\$ -	\$ -	\$ -	\$ -	\$ -	\$ -	\$ -	\$ -
97	Jul	2018	\$ -	\$ -	\$ -	\$ -	\$ -	\$ -	\$ -	\$ -	\$ -	\$ -	\$ -
98	Aug	2018	\$ -	\$ -	\$ -	\$ -	\$ -	\$ -	\$ -	\$ -	\$ -	\$ -	\$ -
99	Sep	2018	\$ -	\$ -	\$ -	\$ -	\$ -	\$ -	\$ -	\$ -	\$ -	\$ -	\$ -
100	Oct	2018	\$ -	\$ -	\$ -	\$ -	\$ -	\$ -	\$ -	\$ -	\$ -	\$ -	\$ -
101	Nov	2018	\$ -	\$ -	\$ -	\$ -	\$ -	\$ -	\$ -	\$ -	\$ -	\$ -	\$ -
102	Dec	2018	\$ -	\$ -	\$ -	\$ -	\$ -	\$ -	\$ -	\$ -	\$ -	\$ -	\$ -
103													
104	13 Mon Avg	\$	\$ -	\$ -	\$ -	\$ -	\$ -	\$ -	\$ -	\$ -	\$ -	\$ -	\$ -
105	12 Mon Depr Exp	\$	\$ -	\$ -	\$ -	\$ -	\$ -	\$ -	\$ -	\$ -	\$ -	\$ -	\$ -

Notes:

- (B) P-4 projects should be included in total projected transmission projects for P-1
- (C) Projects should not be listed until the first year they are expected to be in service. Do not duplicate projects listed in A-7 (Act.RTO Directed Proj).

**Sunflower Electric Power Corporation (SEPC)
Projected Transmission Plant Related Projects -RTO Directed Projects (B & C)
For the 12 months ended - December 31, 2018**

Total Base Plan Projects (Operating Leases)					Mingo Transformer/Terminal Upgrades								
					Project: 1			Project: 2			Project: 3		
					SPP Proj. ID	30427		SPP Proj. ID			SPP Proj. ID		
					Sum of Monthly Lease Payments 2018	\$ 1,352,222		Sum of Monthly Lease Payments 2018			Sum of Monthly Lease Payments 2018		
					Begin Plant in Serv.	\$ -		Begin Plant in Serv.	\$ -		Begin Plant in Serv.		
					Begin. Acc. Amort:	\$ -		Begin. Acc. Amort:	\$ -		Begin. Acc. Amort:		
					Begin. Year-Mo.:	Jan-17		Begin. Year-Mo.:			Begin. Year-Mo.:		
Mon.	Year	Total			Gross Plant	Accm. Amort.	Net Plant	Gross Plant	Accm. Amort.	Net Plant	Gross Plant	Accm. Amort.	Net Plant
					\$ -			\$ -			\$ -		
Jan	2017	\$ 12,929,229	\$ -	\$ 12,929,229	\$ 12,929,229	\$ -	\$ 12,929,229	\$ -	\$ -	\$ -	\$ -	\$ -	\$ -
Feb	2017	\$ 12,929,229	\$ -	\$ 12,929,229	\$ 12,929,229	\$ -	\$ 12,929,229	\$ -	\$ -	\$ -	\$ -	\$ -	\$ -
Mar	2017	\$ 12,929,229	\$ -	\$ 12,929,229	\$ 12,929,229	\$ -	\$ 12,929,229	\$ -	\$ -	\$ -	\$ -	\$ -	\$ -
Apr	2017	\$ 12,929,229	\$ -	\$ 12,929,229	\$ 12,929,229	\$ -	\$ 12,929,229	\$ -	\$ -	\$ -	\$ -	\$ -	\$ -
May	2017	\$ 12,929,229	\$ -	\$ 12,929,229	\$ 12,929,229	\$ -	\$ 12,929,229	\$ -	\$ -	\$ -	\$ -	\$ -	\$ -
Jun	2017	\$ 12,929,229	\$ -	\$ 12,929,229	\$ 12,929,229	\$ -	\$ 12,929,229	\$ -	\$ -	\$ -	\$ -	\$ -	\$ -
Jul	2017	\$ 12,929,229	\$ 16,885	\$ 12,912,344	\$ 12,929,229	\$ 16,885	\$ 12,912,344	\$ -	\$ -	\$ -	\$ -	\$ -	\$ -
Aug	2017	\$ 12,929,229	\$ 16,885	\$ 12,912,344	\$ 12,929,229	\$ 16,885	\$ 12,912,344	\$ -	\$ -	\$ -	\$ -	\$ -	\$ -
Sep	2017	\$ 12,929,229	\$ 16,885	\$ 12,912,344	\$ 12,929,229	\$ 16,885	\$ 12,912,344	\$ -	\$ -	\$ -	\$ -	\$ -	\$ -
Oct	2017	\$ 12,929,229	\$ 16,885	\$ 12,912,344	\$ 12,929,229	\$ 16,885	\$ 12,912,344	\$ -	\$ -	\$ -	\$ -	\$ -	\$ -
No	2017	\$ 12,929,229	\$ 16,885	\$ 12,912,344	\$ 12,929,229	\$ 16,885	\$ 12,912,344	\$ -	\$ -	\$ -	\$ -	\$ -	\$ -
Dec	2017	\$ 12,929,229	\$ 16,885	\$ 12,912,344	\$ 12,929,229	\$ 16,885	\$ 12,912,344	\$ -	\$ -	\$ -	\$ -	\$ -	\$ -
Jan	2018	\$ 12,929,229	\$ 16,885	\$ 12,912,344	\$ 12,929,229	\$ 16,885	\$ 12,912,344	\$ -	\$ -	\$ -	\$ -	\$ -	\$ -
Feb	2018	\$ 12,929,229	\$ 16,885	\$ 12,912,344	\$ 12,929,229	\$ 16,885	\$ 12,912,344	\$ -	\$ -	\$ -	\$ -	\$ -	\$ -
Mar	2018	\$ 12,929,229	\$ 16,885	\$ 12,912,344	\$ 12,929,229	\$ 16,885	\$ 12,912,344	\$ -	\$ -	\$ -	\$ -	\$ -	\$ -
Apr	2018	\$ 12,929,229	\$ 16,885	\$ 12,912,344	\$ 12,929,229	\$ 16,885	\$ 12,912,344	\$ -	\$ -	\$ -	\$ -	\$ -	\$ -
May	2018	\$ 12,929,229	\$ 16,885	\$ 12,912,344	\$ 12,929,229	\$ 16,885	\$ 12,912,344	\$ -	\$ -	\$ -	\$ -	\$ -	\$ -
Jun	2018	\$ 12,929,229	\$ 16,885	\$ 12,912,344	\$ 12,929,229	\$ 16,885	\$ 12,912,344	\$ -	\$ -	\$ -	\$ -	\$ -	\$ -
Jul	2018	\$ 12,929,229	\$ 17,689	\$ 12,911,540	\$ 12,929,229	\$ 17,689	\$ 12,911,540	\$ -	\$ -	\$ -	\$ -	\$ -	\$ -
Aug	2018	\$ 12,929,229	\$ 17,689	\$ 12,911,540	\$ 12,929,229	\$ 17,689	\$ 12,911,540	\$ -	\$ -	\$ -	\$ -	\$ -	\$ -
Sep	2018	\$ 12,929,229	\$ 17,689	\$ 12,911,540	\$ 12,929,229	\$ 17,689	\$ 12,911,540	\$ -	\$ -	\$ -	\$ -	\$ -	\$ -
Oct	2018	\$ 12,929,229	\$ 17,689	\$ 12,911,540	\$ 12,929,229	\$ 17,689	\$ 12,911,540	\$ -	\$ -	\$ -	\$ -	\$ -	\$ -
Nov	2018	\$ 12,929,229	\$ 17,689	\$ 12,911,540	\$ 12,929,229	\$ 17,689	\$ 12,911,540	\$ -	\$ -	\$ -	\$ -	\$ -	\$ -
Dec	2018	\$ 12,929,229	\$ 17,689	\$ 12,911,540	\$ 12,929,229	\$ 17,689	\$ 12,911,540	\$ -	\$ -	\$ -	\$ -	\$ -	\$ -
13 Mon Avg		\$ 12,929,229	\$ 17,256	\$ 12,911,973	\$ 12,929,229	\$ 17,256	\$ 12,911,973	\$ -	\$ -	\$ -	\$ -	\$ -	\$ -
12 Mon Depr Exp			\$ 804		12 Mon Depr Exp	\$ 804		12 Mon Depr Exp	\$ -		12 Mon Depr Exp	\$ -	

Notes:

(B) P-4 projects should be included in total projected transmission projects for P-1

(C) Projects should not be listed until the first year they are expected to be in service. Do not duplicate projects listed in A-7 (Act.RTO Directed Proj).

**Sunflower Electric Power Corporation (SEPC)
Projected Transmission Plant Related Projects -RTO Directed Projects (B & C)
For the 12 months ended - December 31, 2018**

141 Total Balanced Portfolio Projects													
142													
143													
144													
145													
146													
147													
148													
149													
150													
151													
152													
153													
154													
155													
156													
157													
158													
159													
160													
161													
162													
163													
164													
165													
166													
167													
168													
169													
170													
171													
172													
173													
174													
175													
176													
			Description			Description			Description				
			Project:	1		Project:	2		Project:	3			
			SPP Proj. ID		SPP Proj. ID		SPP Proj. ID		SPP Proj. ID				
			Depr. Rate:	0.1405% (A)	Depr. Rate:	0.1405% (A)	Depr. Rate:	0.1405% (A)	Depr. Rate:	0.1405% (A)			
			Begin Plant in Serv.	\$ -	Begin Plant in Serv.	\$ -	Begin Plant in Serv.	\$ -	Begin Plant in Serv.	\$ -			
			Begin. Acc. Depr:	\$ -	Begin. Acc. Depr:	\$ -	Begin. Acc. Depr:	\$ -	Begin. Acc. Depr:	\$ -			
			Begin. Year-Mo.:		Begin. Year-Mo.:		Begin. Year-Mo.:		Begin. Year-Mo.:				
Month	Year	Total			Gross Plant	Accm. Depr.	Net Plant	Gross Plant	Accm. Depr.	Net Plant	Gross Plant	Accm. Depr.	Net Plant
					\$ -	\$ -	\$ -	\$ -	\$ -	\$ -	\$ -	\$ -	\$ -
Jan	2017	\$ -	\$ -	\$ -	\$ -	\$ -	\$ -	\$ -	\$ -	\$ -	\$ -	\$ -	\$ -
Feb	2017	\$ -	\$ -	\$ -	\$ -	\$ -	\$ -	\$ -	\$ -	\$ -	\$ -	\$ -	\$ -
Mar	2017	\$ -	\$ -	\$ -	\$ -	\$ -	\$ -	\$ -	\$ -	\$ -	\$ -	\$ -	\$ -
Apr	2017	\$ -	\$ -	\$ -	\$ -	\$ -	\$ -	\$ -	\$ -	\$ -	\$ -	\$ -	\$ -
May	2017	\$ -	\$ -	\$ -	\$ -	\$ -	\$ -	\$ -	\$ -	\$ -	\$ -	\$ -	\$ -
Jun	2017	\$ -	\$ -	\$ -	\$ -	\$ -	\$ -	\$ -	\$ -	\$ -	\$ -	\$ -	\$ -
Jul	2017	\$ -	\$ -	\$ -	\$ -	\$ -	\$ -	\$ -	\$ -	\$ -	\$ -	\$ -	\$ -
Aug	2017	\$ -	\$ -	\$ -	\$ -	\$ -	\$ -	\$ -	\$ -	\$ -	\$ -	\$ -	\$ -
Sep	2017	\$ -	\$ -	\$ -	\$ -	\$ -	\$ -	\$ -	\$ -	\$ -	\$ -	\$ -	\$ -
Oct	2017	\$ -	\$ -	\$ -	\$ -	\$ -	\$ -	\$ -	\$ -	\$ -	\$ -	\$ -	\$ -
No	2017	\$ -	\$ -	\$ -	\$ -	\$ -	\$ -	\$ -	\$ -	\$ -	\$ -	\$ -	\$ -
Dec	2017	\$ -	\$ -	\$ -	\$ -	\$ -	\$ -	\$ -	\$ -	\$ -	\$ -	\$ -	\$ -
Jan	2018	\$ -	\$ -	\$ -	\$ -	\$ -	\$ -	\$ -	\$ -	\$ -	\$ -	\$ -	\$ -
Feb	2018	\$ -	\$ -	\$ -	\$ -	\$ -	\$ -	\$ -	\$ -	\$ -	\$ -	\$ -	\$ -
Mar	2018	\$ -	\$ -	\$ -	\$ -	\$ -	\$ -	\$ -	\$ -	\$ -	\$ -	\$ -	\$ -
Apr	2018	\$ -	\$ -	\$ -	\$ -	\$ -	\$ -	\$ -	\$ -	\$ -	\$ -	\$ -	\$ -
May	2018	\$ -	\$ -	\$ -	\$ -	\$ -	\$ -	\$ -	\$ -	\$ -	\$ -	\$ -	\$ -
Jun	2018	\$ -	\$ -	\$ -	\$ -	\$ -	\$ -	\$ -	\$ -	\$ -	\$ -	\$ -	\$ -
Jul	2018	\$ -	\$ -	\$ -	\$ -	\$ -	\$ -	\$ -	\$ -	\$ -	\$ -	\$ -	\$ -
Aug	2018	\$ -	\$ -	\$ -	\$ -	\$ -	\$ -	\$ -	\$ -	\$ -	\$ -	\$ -	\$ -
Sep	2018	\$ -	\$ -	\$ -	\$ -	\$ -	\$ -	\$ -	\$ -	\$ -	\$ -	\$ -	\$ -
Oct	2018	\$ -	\$ -	\$ -	\$ -	\$ -	\$ -	\$ -	\$ -	\$ -	\$ -	\$ -	\$ -
No	2018	\$ -	\$ -	\$ -	\$ -	\$ -	\$ -	\$ -	\$ -	\$ -	\$ -	\$ -	\$ -
Dec	2018	\$ -	\$ -	\$ -	\$ -	\$ -	\$ -	\$ -	\$ -	\$ -	\$ -	\$ -	\$ -
13 Mon Avg		\$ -	\$ -	\$ -	\$ -	\$ -	\$ -	\$ -	\$ -	\$ -	\$ -	\$ -	\$ -
12 Mon Depr Exp		\$ -	\$ -	\$ -	\$ -	\$ -	\$ -	\$ -	\$ -	\$ -	\$ -	\$ -	\$ -

Notes:

(A) See WP A-5 (Act Depreciation.Rate).

(B) P-4 projects should be included in total projected transmission projects for P-1

(C) Projects should not be listed until the first year they are expected to be in service unless there is a CWIP return incentive. Do not duplicate projects listed in A-7 (Act. RTO Proj).

Sunflower Electric Power Corporation (SEPC)
Projected Transmission Plant Related Projects -RTO Directed Projects (B & C)
For the 12 months ended - December 31, 2018

177 Total ITP / Priority Projects-1					<i>Description</i>			<i>Description</i>			<i>Description</i>					
178					Project:	1			Project:	2			Project:	3		
179					SPP Proj. ID				SPP Proj. ID				SPP Proj. ID			
180					Depr. Rate:	0.1405% (A)			Depr. Rate:	0.1405% (A)			Depr. Rate:	0.1405% (A)		
181					Beginning Bal:				Begin Plant in Serv.				Begin Plant in Serv.			
182					Beginning Dep:				Begin. Acc. Depr:				Begin. Acc. Depr:			
183					Begin. Year-Mo.:				Begin. Year-Mo.:				Begin. Year-Mo.:			
184	Month	Year	Total			Gross Plant	Accm. Depr.	Net Plant	Gross Plant	Accm. Depr.	Net Plant	Gross Plant	Accm. Depr.	Net Plant		
185																
186	Jan	2017	\$ -	\$ -	\$ -	\$ -	\$ -	\$ -	\$ -	\$ -	\$ -	\$ -	\$ -	\$ -		
187	Feb	2017	\$ -	\$ -	\$ -	\$ -	\$ -	\$ -	\$ -	\$ -	\$ -	\$ -	\$ -	\$ -		
188	Mar	2017	\$ -	\$ -	\$ -	\$ -	\$ -	\$ -	\$ -	\$ -	\$ -	\$ -	\$ -	\$ -		
189	Apr	2017	\$ -	\$ -	\$ -	\$ -	\$ -	\$ -	\$ -	\$ -	\$ -	\$ -	\$ -	\$ -		
190	May	2017	\$ -	\$ -	\$ -	\$ -	\$ -	\$ -	\$ -	\$ -	\$ -	\$ -	\$ -	\$ -		
191	Jun	2017	\$ -	\$ -	\$ -	\$ -	\$ -	\$ -	\$ -	\$ -	\$ -	\$ -	\$ -	\$ -		
192	Jul	2017	\$ -	\$ -	\$ -	\$ -	\$ -	\$ -	\$ -	\$ -	\$ -	\$ -	\$ -	\$ -		
193	Aug	2017	\$ -	\$ -	\$ -	\$ -	\$ -	\$ -	\$ -	\$ -	\$ -	\$ -	\$ -	\$ -		
194	Sep	2017	\$ -	\$ -	\$ -	\$ -	\$ -	\$ -	\$ -	\$ -	\$ -	\$ -	\$ -	\$ -		
195	Oct	2017	\$ -	\$ -	\$ -	\$ -	\$ -	\$ -	\$ -	\$ -	\$ -	\$ -	\$ -	\$ -		
196	No	2017	\$ -	\$ -	\$ -	\$ -	\$ -	\$ -	\$ -	\$ -	\$ -	\$ -	\$ -	\$ -		
197	Dec	2017	\$ -	\$ -	\$ -	\$ -	\$ -	\$ -	\$ -	\$ -	\$ -	\$ -	\$ -	\$ -		
198	Jan	2018	\$ -	\$ -	\$ -	\$ -	\$ -	\$ -	\$ -	\$ -	\$ -	\$ -	\$ -	\$ -		
199	Feb	2018	\$ -	\$ -	\$ -	\$ -	\$ -	\$ -	\$ -	\$ -	\$ -	\$ -	\$ -	\$ -		
200	Mar	2018	\$ -	\$ -	\$ -	\$ -	\$ -	\$ -	\$ -	\$ -	\$ -	\$ -	\$ -	\$ -		
201	Apr	2018	\$ -	\$ -	\$ -	\$ -	\$ -	\$ -	\$ -	\$ -	\$ -	\$ -	\$ -	\$ -		
202	May	2018	\$ -	\$ -	\$ -	\$ -	\$ -	\$ -	\$ -	\$ -	\$ -	\$ -	\$ -	\$ -		
203	Jun	2018	\$ -	\$ -	\$ -	\$ -	\$ -	\$ -	\$ -	\$ -	\$ -	\$ -	\$ -	\$ -		
204	Jul	2018	\$ -	\$ -	\$ -	\$ -	\$ -	\$ -	\$ -	\$ -	\$ -	\$ -	\$ -	\$ -		
205	Aug	2018	\$ -	\$ -	\$ -	\$ -	\$ -	\$ -	\$ -	\$ -	\$ -	\$ -	\$ -	\$ -		
206	Sep	2018	\$ -	\$ -	\$ -	\$ -	\$ -	\$ -	\$ -	\$ -	\$ -	\$ -	\$ -	\$ -		
207	Oct	2018	\$ -	\$ -	\$ -	\$ -	\$ -	\$ -	\$ -	\$ -	\$ -	\$ -	\$ -	\$ -		
208	No	2018	\$ -	\$ -	\$ -	\$ -	\$ -	\$ -	\$ -	\$ -	\$ -	\$ -	\$ -	\$ -		
209	Dec	2018	\$ -	\$ -	\$ -	\$ -	\$ -	\$ -	\$ -	\$ -	\$ -	\$ -	\$ -	\$ -		
210																
211	13 Mon Avg		\$ -	\$ -	\$ -	\$ -	\$ -	\$ -	\$ -	\$ -	\$ -	\$ -	\$ -	\$ -		
212	12 Mon Depr Exp		\$ -	\$ -	\$ -	12 Mon Depr Exp	\$ -	\$ -	12 Mon Depr Exp	\$ -	\$ -	12 Mon Depr Exp	\$ -	\$ -		

Notes:

(A) See WP A-5 (Act Depreciation.Rate).

(B) P-4 projects should be included in total projected transmission projects for P-1

(C) Projects should not be listed until the first year they are expected to be in service unless there is a CWIP return incentive. Do not duplicate projects listed in A-7 (Act. RTO Proj).

Sunflower Electric Power Corporation (SEPC)
Projected Transmission Plant Related Projects -RTO Directed Projects (B & C)
For the 12 months ended - December 31, 2018

		<i>Description</i>			<i>Description</i>			<i>Description</i>			
213	Total ITP / Priority Projects-2	Project:	1		Project:	2		Project:	3		
214		SPP Proj. ID			SPP Proj. ID			SPP Proj. ID			
215		Depr. Rate:	0.1405% (A)		Depr. Rate:	0.1405% (A)		Depr. Rate:	0.1405% (A)		
216		Begin Plant in Serv.			Begin Plant in Serv.			Begin Plant in Serv.			
217		Begin. Acc. Depr:			Begin. Acc. Depr:			Begin. Acc. Depr:			
218		Begin. Year-Mo.:			Begin. Year-Mo.:			Begin. Year-Mo.:			
219		Total									
220	Month	Year	Gross Plant	Accm. Depr.	Net Plant	Gross Plant	Accm. Depr.	Net Plant	Gross Plant	Accm. Depr.	Net Plant
221			\$ -	\$ -	\$ -	\$ -	\$ -	\$ -	\$ -	\$ -	\$ -
222	Jan	2017	\$ -	\$ -	\$ -	\$ -	\$ -	\$ -	\$ -	\$ -	\$ -
223	Feb	2017	\$ -	\$ -	\$ -	\$ -	\$ -	\$ -	\$ -	\$ -	\$ -
224	Mar	2017	\$ -	\$ -	\$ -	\$ -	\$ -	\$ -	\$ -	\$ -	\$ -
225	Apr	2017	\$ -	\$ -	\$ -	\$ -	\$ -	\$ -	\$ -	\$ -	\$ -
226	May	2017	\$ -	\$ -	\$ -	\$ -	\$ -	\$ -	\$ -	\$ -	\$ -
227	Jun	2017	\$ -	\$ -	\$ -	\$ -	\$ -	\$ -	\$ -	\$ -	\$ -
228	Jul	2017	\$ -	\$ -	\$ -	\$ -	\$ -	\$ -	\$ -	\$ -	\$ -
229	Aug	2017	\$ -	\$ -	\$ -	\$ -	\$ -	\$ -	\$ -	\$ -	\$ -
230	Sep	2017	\$ -	\$ -	\$ -	\$ -	\$ -	\$ -	\$ -	\$ -	\$ -
231	Oct	2017	\$ -	\$ -	\$ -	\$ -	\$ -	\$ -	\$ -	\$ -	\$ -
232	No	2017	\$ -	\$ -	\$ -	\$ -	\$ -	\$ -	\$ -	\$ -	\$ -
233	Dec	2017	\$ -	\$ -	\$ -	\$ -	\$ -	\$ -	\$ -	\$ -	\$ -
234	Jan	2018	\$ -	\$ -	\$ -	\$ -	\$ -	\$ -	\$ -	\$ -	\$ -
235	Feb	2018	\$ -	\$ -	\$ -	\$ -	\$ -	\$ -	\$ -	\$ -	\$ -
236	Mar	2018	\$ -	\$ -	\$ -	\$ -	\$ -	\$ -	\$ -	\$ -	\$ -
237	Apr	2018	\$ -	\$ -	\$ -	\$ -	\$ -	\$ -	\$ -	\$ -	\$ -
238	May	2018	\$ -	\$ -	\$ -	\$ -	\$ -	\$ -	\$ -	\$ -	\$ -
239	Jun	2018	\$ -	\$ -	\$ -	\$ -	\$ -	\$ -	\$ -	\$ -	\$ -
240	Jul	2018	\$ -	\$ -	\$ -	\$ -	\$ -	\$ -	\$ -	\$ -	\$ -
241	Aug	2018	\$ -	\$ -	\$ -	\$ -	\$ -	\$ -	\$ -	\$ -	\$ -
242	Sep	2018	\$ -	\$ -	\$ -	\$ -	\$ -	\$ -	\$ -	\$ -	\$ -
243	Oct	2018	\$ -	\$ -	\$ -	\$ -	\$ -	\$ -	\$ -	\$ -	\$ -
244	No	2018	\$ -	\$ -	\$ -	\$ -	\$ -	\$ -	\$ -	\$ -	\$ -
245	Dec	2018	\$ -	\$ -	\$ -	\$ -	\$ -	\$ -	\$ -	\$ -	\$ -
246											
247	13 Mon Avg	\$	\$ -	\$ -	\$ -	\$ -	\$ -	\$ -	\$ -	\$ -	\$ -
248	12 Mon Depr Exp	\$	\$ -	\$ -	\$ -	\$ -	\$ -	\$ -	\$ -	\$ -	\$ -

Notes:

- (A) See WP A-5 (Act Depreciation.Rate).
- (B) P-4 projects should be included in total projected transmission projects for P-1
- (C) Projects should not be listed until the first year they are expected to be in service unless there is a CWIP return incentive. Do not duplicate projects listed in A-7 (Act. RTO Proj).

Sunflower Electric Power Corporation (SEPC)
Projected Transmission Plant Related to Sponsored Projects
For the 12 months ended - December 31, 2018

1 Total Sponsor Funded Projects (B & C)					<i>Description</i>			<i>Description</i>			<i>Description</i>		
					Project: 1			Project: 2			Project: 3		
					Begin. Year-Mo.:			SPP Proj. ID			SPP Proj. ID		
					Depr. Rate: 0.1405% (A)			Depr. Rate: 0.1405% (A)			Depr. Rate: 0.1405% (A)		
					Begin Plant in Serv.:			Begin Plant in Serv.:			Begin Plant in Serv.:		
					Begin. Acc. Depr.:			Begin. Acc. Depr.:			Begin. Acc. Depr.:		
					Begin. Year-Mo.:			Begin. Year-Mo.:			Beg Year-Mo.:		
Mon.	Year	Total			Gross Plant	Accm. Depr.	Net Plant	Gross Plant	Accm. Depr.	Net Plant	Gross Plant	Accm. Depr.	Net Plant
					\$ -			\$ -			\$ -		
10	Jan 2017	\$ -	\$ -	\$ -	\$ -	\$ -	\$ -	\$ -	\$ -	\$ -	\$ -	\$ -	\$ -
11	Feb 2017	\$ -	\$ -	\$ -	\$ -	\$ -	\$ -	\$ -	\$ -	\$ -	\$ -	\$ -	\$ -
12	Mar 2017	\$ -	\$ -	\$ -	\$ -	\$ -	\$ -	\$ -	\$ -	\$ -	\$ -	\$ -	\$ -
13	Apr 2017	\$ -	\$ -	\$ -	\$ -	\$ -	\$ -	\$ -	\$ -	\$ -	\$ -	\$ -	\$ -
14	May 2017	\$ -	\$ -	\$ -	\$ -	\$ -	\$ -	\$ -	\$ -	\$ -	\$ -	\$ -	\$ -
15	Jun 2017	\$ -	\$ -	\$ -	\$ -	\$ -	\$ -	\$ -	\$ -	\$ -	\$ -	\$ -	\$ -
16	Jul 2017	\$ -	\$ -	\$ -	\$ -	\$ -	\$ -	\$ -	\$ -	\$ -	\$ -	\$ -	\$ -
17	Aug 2017	\$ -	\$ -	\$ -	\$ -	\$ -	\$ -	\$ -	\$ -	\$ -	\$ -	\$ -	\$ -
18	Sep 2017	\$ -	\$ -	\$ -	\$ -	\$ -	\$ -	\$ -	\$ -	\$ -	\$ -	\$ -	\$ -
19	Oct 2017	\$ -	\$ -	\$ -	\$ -	\$ -	\$ -	\$ -	\$ -	\$ -	\$ -	\$ -	\$ -
20	No 2017	\$ -	\$ -	\$ -	\$ -	\$ -	\$ -	\$ -	\$ -	\$ -	\$ -	\$ -	\$ -
21	Dec 2017	\$ -	\$ -	\$ -	\$ -	\$ -	\$ -	\$ -	\$ -	\$ -	\$ -	\$ -	\$ -
22	Jan 2018	\$ -	\$ -	\$ -	\$ -	\$ -	\$ -	\$ -	\$ -	\$ -	\$ -	\$ -	\$ -
23	Feb 2018	\$ -	\$ -	\$ -	\$ -	\$ -	\$ -	\$ -	\$ -	\$ -	\$ -	\$ -	\$ -
24	Mar 2018	\$ -	\$ -	\$ -	\$ -	\$ -	\$ -	\$ -	\$ -	\$ -	\$ -	\$ -	\$ -
25	Apr 2018	\$ -	\$ -	\$ -	\$ -	\$ -	\$ -	\$ -	\$ -	\$ -	\$ -	\$ -	\$ -
26	May 2018	\$ -	\$ -	\$ -	\$ -	\$ -	\$ -	\$ -	\$ -	\$ -	\$ -	\$ -	\$ -
27	Jun 2018	\$ -	\$ -	\$ -	\$ -	\$ -	\$ -	\$ -	\$ -	\$ -	\$ -	\$ -	\$ -
28	Jul 2018	\$ -	\$ -	\$ -	\$ -	\$ -	\$ -	\$ -	\$ -	\$ -	\$ -	\$ -	\$ -
29	Aug 2018	\$ -	\$ -	\$ -	\$ -	\$ -	\$ -	\$ -	\$ -	\$ -	\$ -	\$ -	\$ -
30	Sep 2018	\$ -	\$ -	\$ -	\$ -	\$ -	\$ -	\$ -	\$ -	\$ -	\$ -	\$ -	\$ -
31	Oct 2018	\$ -	\$ -	\$ -	\$ -	\$ -	\$ -	\$ -	\$ -	\$ -	\$ -	\$ -	\$ -
32	No 2018	\$ -	\$ -	\$ -	\$ -	\$ -	\$ -	\$ -	\$ -	\$ -	\$ -	\$ -	\$ -
33	Dec 2018	\$ -	\$ -	\$ -	\$ -	\$ -	\$ -	\$ -	\$ -	\$ -	\$ -	\$ -	\$ -
34													
35	13 Mon Avg	\$ -	\$ -	\$ -	\$ -	\$ -	\$ -	\$ -	\$ -	\$ -	\$ -	\$ -	\$ -
36	12 Mon Depr Exp	\$ -	\$ -	\$ -	12 Mon Depr Exp	\$ -	\$ -	12 Mon Depr Exp	\$ -	\$ -	12 Mon Depr Exp	\$ -	\$ -

Notes: (A) See WP A-5 (Act Depreciation.Rate).
 (B) P-5 projects should be included in total projected transmission projects for P-1
 (C) Projects should not be listed until the first year they are expected to be in service. Do not duplicate projects listed in A-8 (Act. Sponsor).

Sunflower Electric Power Corporation (SEPC)
Projected Transmission Plant Related to Third Party Projects
For the 12 months ended - December 31, 2018

1 Total Projects Funded for Third Parties (B & C)				Description			Description			Description			
				Project: 1			Project: 2			Project: 3			
2				SPP Proj. ID			SPP Proj. ID			SPP Proj. ID			
3				Depr. Rate: 0.1405% (A)			Depr. Rate: 0.1405% (A)			Depr. Rate: 0.1405% (A)			
4				Begin Plant in Serv. \$ -			Begin Plant in Serv. \$ -			Begin Plant in Serv. \$ -			
5				Begin. Acc. Depr: -			Begin. Acc. Depr: -			Begin. Acc. Depr: -			
6				Begin. Year-Mo.:			Begin. Year-Mo.:			Begin. Year-Mo.:			
7				Third Party:			Third Party:			Third Party:			
8 Mon.	8 Year	Total			Gross Plant	Accm. Depr.	Net Plant	Gross Plant	Accm. Depr.	Net Plant	Gross Plant	Accm. Depr.	Net Plant
9													
10				\$ -	\$ -	\$ -	\$ -	\$ -	\$ -	\$ -	\$ -	\$ -	\$ -
11				\$ -	\$ -	\$ -	\$ -	\$ -	\$ -	\$ -	\$ -	\$ -	\$ -
12				\$ -	\$ -	\$ -	\$ -	\$ -	\$ -	\$ -	\$ -	\$ -	\$ -
13				\$ -	\$ -	\$ -	\$ -	\$ -	\$ -	\$ -	\$ -	\$ -	\$ -
14				\$ -	\$ -	\$ -	\$ -	\$ -	\$ -	\$ -	\$ -	\$ -	\$ -
15				\$ -	\$ -	\$ -	\$ -	\$ -	\$ -	\$ -	\$ -	\$ -	\$ -
16				\$ -	\$ -	\$ -	\$ -	\$ -	\$ -	\$ -	\$ -	\$ -	\$ -
17				\$ -	\$ -	\$ -	\$ -	\$ -	\$ -	\$ -	\$ -	\$ -	\$ -
18				\$ -	\$ -	\$ -	\$ -	\$ -	\$ -	\$ -	\$ -	\$ -	\$ -
19				\$ -	\$ -	\$ -	\$ -	\$ -	\$ -	\$ -	\$ -	\$ -	\$ -
20				\$ -	\$ -	\$ -	\$ -	\$ -	\$ -	\$ -	\$ -	\$ -	\$ -
21				\$ -	\$ -	\$ -	\$ -	\$ -	\$ -	\$ -	\$ -	\$ -	\$ -
22				\$ -	\$ -	\$ -	\$ -	\$ -	\$ -	\$ -	\$ -	\$ -	\$ -
23				\$ -	\$ -	\$ -	\$ -	\$ -	\$ -	\$ -	\$ -	\$ -	\$ -
24				\$ -	\$ -	\$ -	\$ -	\$ -	\$ -	\$ -	\$ -	\$ -	\$ -
25				\$ -	\$ -	\$ -	\$ -	\$ -	\$ -	\$ -	\$ -	\$ -	\$ -
26				\$ -	\$ -	\$ -	\$ -	\$ -	\$ -	\$ -	\$ -	\$ -	\$ -
27				\$ -	\$ -	\$ -	\$ -	\$ -	\$ -	\$ -	\$ -	\$ -	\$ -
28				\$ -	\$ -	\$ -	\$ -	\$ -	\$ -	\$ -	\$ -	\$ -	\$ -
29				\$ -	\$ -	\$ -	\$ -	\$ -	\$ -	\$ -	\$ -	\$ -	\$ -
30				\$ -	\$ -	\$ -	\$ -	\$ -	\$ -	\$ -	\$ -	\$ -	\$ -
31				\$ -	\$ -	\$ -	\$ -	\$ -	\$ -	\$ -	\$ -	\$ -	\$ -
32				\$ -	\$ -	\$ -	\$ -	\$ -	\$ -	\$ -	\$ -	\$ -	\$ -
33				\$ -	\$ -	\$ -	\$ -	\$ -	\$ -	\$ -	\$ -	\$ -	\$ -
34													
35				13 Mon Avg \$ -	\$ -	\$ -	\$ -	\$ -	\$ -	\$ -	\$ -	\$ -	\$ -
36				12 Mon Depr Exp \$ -	\$ -	\$ -	12 Mon Depr Exp \$ -	\$ -	\$ -	12 Mon Depr Exp \$ -	\$ -	\$ -	

Notes: (A) See WP A-5 (Act Depreciation.Rate).
 (B) P-6 (Third Party Projects) should be included in total projected transmission projects on Worksheet P-1
 (C) Projects should not be listed until the first year they are expected to be in service. Do not duplicate projects listed in A-10 (Act. Third Party Proj).

2018 Sunflower Annual Update
Summary of Projected Transmission Facilities Exceeding \$5 Million

Project #: **30912**

Project Name: **Walkemeyer Tap - Walkemeyer 345/115 kV**

Date of Completion **Jun-18**

Current Percent Completion: **28%**

Total Cost: **\$9,763,391**

Categorization: **Regional Reliability**

Cost Allocation: **Base Plan**

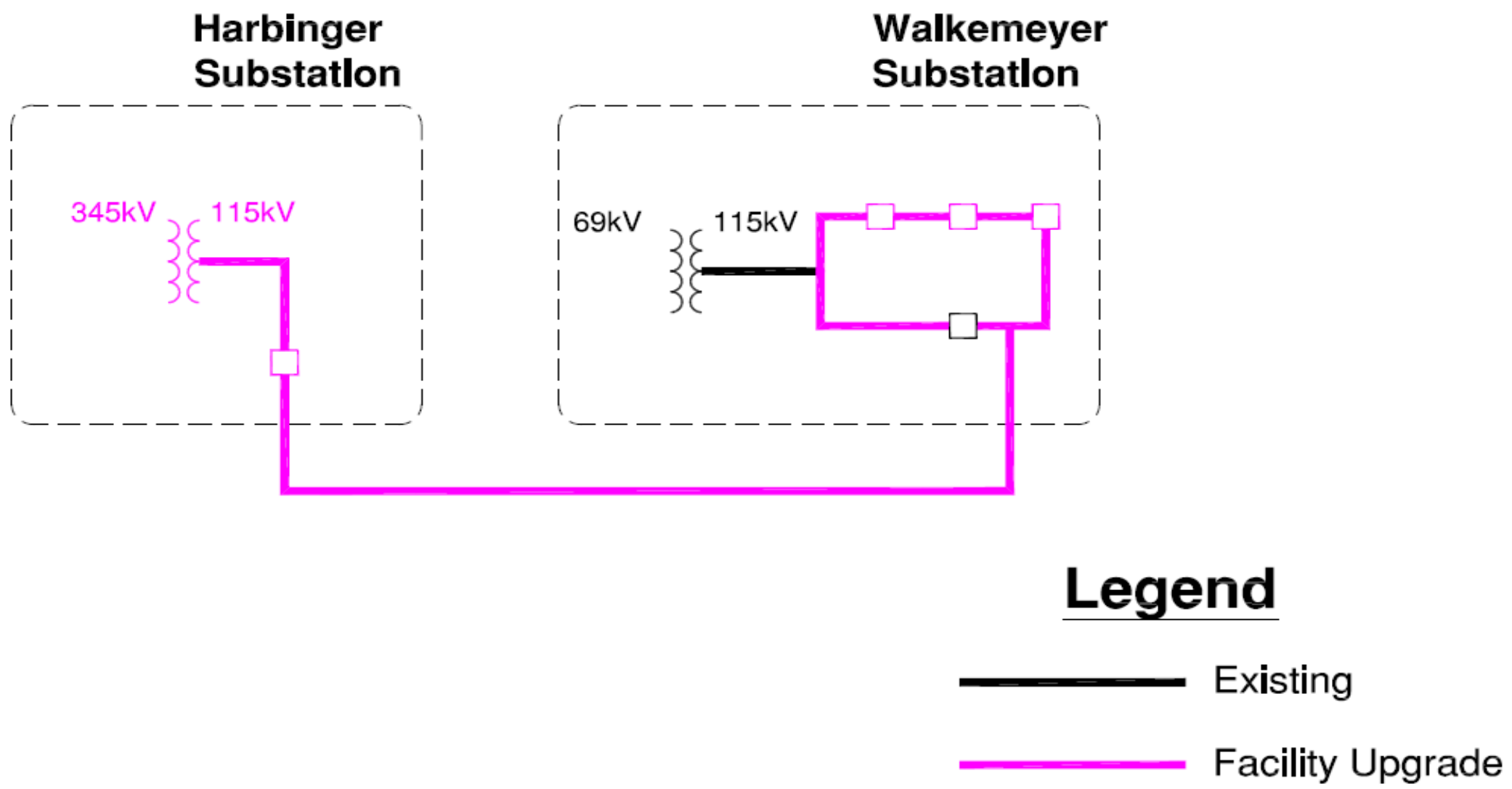

2018 Sunflower Annual Update
Summary of Projected Transmission Facilities Exceeding \$5 Million

Project #: **30427**

Project Name: **Mingo Transformer/ Terminal Upgrades**

Date of Completion **Jan-17**

Current Percent Completion: **100%**

Total Cost: **\$12,929,229**

Categorization: **SPP NTC**

Cost Allocation: **Base Plan**

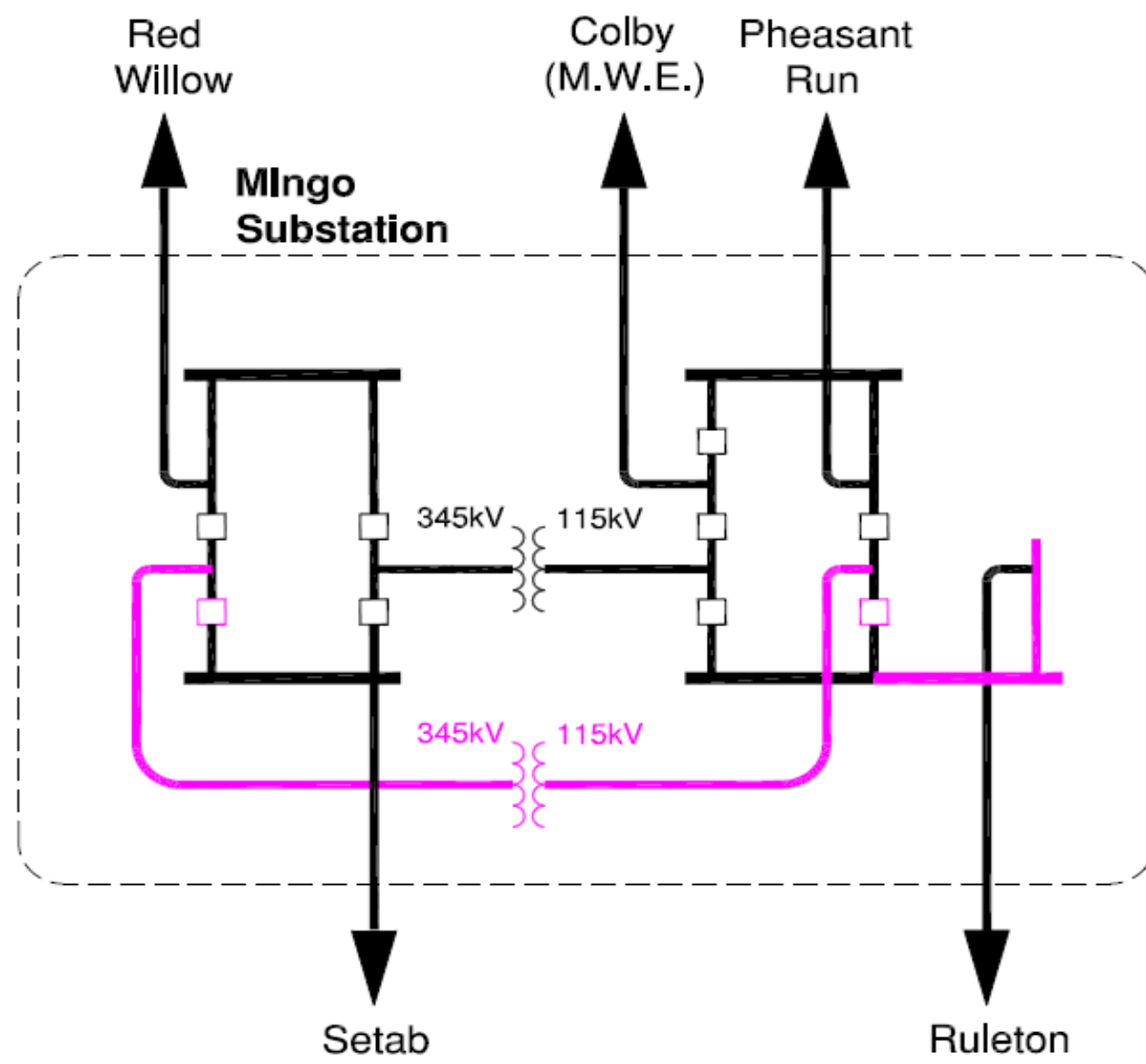

Legend

- Existing
- Facility Upgrade