

APPLICATION TO AMEND INJECTION PERMIT

20-CONS-3079-CUIC

- Salt Water Disposal
- Repressuring
- Other Enhanced Recovery

Permit Number: E-18352 3-JK

SW 1/4 Sec. 29 Twp. 15 S. R. 21 East West

19 Feet from North / South Section Line

4485 Feet from East / West Section Line

Lease: Moldenhauer

Well #: W 4 15-059-19, 30600-01

Franklin County, Kansas

Originally granted to: N/A

(All information above this line taken from the original permit)

Current Operator: License # 32218 Exp. 10/30/19 Contact Person: Lance Town

Company Name: TDR Construction, Inc. Lesli Baker Received

(As listed on operator license) KANSAS CORPORATION COMMISSION

Address: PO Box 339 Louisburg, KS 66053 **AUG 30 2019**

Phone: 913-710-5400 CONSERVATION DIVISION
WICHITA, KS

It is requested that the (caption) (paragraph # _____) of the original permit be amended as follows:

- A. Change the authorized injection pressure to: _____ psi maximum from the current permitted pressure of _____ psi.
- B. Change the authorized injection rate to: _____ bbl/day maximum from the current rate of _____ bbl/day.
- C. Add (_____) or delete (_____) the following leases/facilities supplying produced saltwater or other fluids approved by the Conservation Division.

Company Name	Lease Name	Lease Description
1. _____	_____	_____
2. _____	_____	_____
3. _____	_____	_____
4. _____	_____	_____
5. _____	_____	_____
6. _____	_____	_____
7. _____	_____	_____
8. _____	_____	_____

(Attach additional sheets if necessary)

- D. Change the permit by: (XXXX) add the following repressuring wells: 30 & 45 ;
(_____) change the injection formation; or (_____) change well construction; or (_____) other:

Paid \$100⁰⁰
CK 1350
8/30/19

Offset Operators, Unleased Mineral Owners and Landowners

(Attach additional sheets if necessary)

Name See attached listing from county appraiser office Legal Description of Leasehold _____

I hereby certify that the statements made herein are true and correct to the best of my knowledge and belief.

[Signature]
Applicant or Duly Authorized Agent

Subscribed and sworn to before me this 28 day of August, 2019.

[Signature]
Notary Public

My Commission Expires: 11-3-19

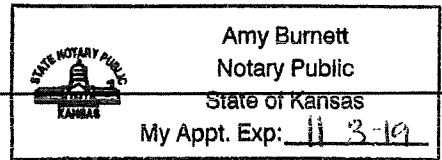

Instructions for Form U-8
Application to Amend Injection Permit

1. All requested changes in injection authority must be submitted with this form.
2. Complete the top portion, (side 1) of the form with the information requested for the pilot well, as shown on the original order or permit.
3. Complete the current operator information, listing the license number, current name and address, contact person and phone number.
4. Fill in the type of change or amendment desired. Leave blank any sections not applicable.
5. For amendments adding additional input wells to enhanced recovery permits, the following information must be submitted in addition to pages 1 and 2 of form U-8:
 - a) pages 1 and 2 of form U-1
 - b) an updated map, showing the new well(s) and all existing wells; page 4 of the form U-1.
 - c) a complete log of the well(s) to be added;
 - d) verification of cement (cement tickets, bond log, etc.)
6. Attach Affidavit of Notice Served, page 5 of form U-1.
7. Attach Affidavit of Publication from the official county newspaper.
8. This form must be signed by the applicant or an authorized agent. A notarization of the signature is required.
9. All applicable fees must accompany this application.

**KANSAS CORPORATION COMMISSION
OIL & GAS CONSERVATION DIVISION
APPLICATION FOR INJECTION WELL**

Form U-1
November 2011
Form must be Typed
Form must be Signed
All blanks must be Filled

Disposal

Enhanced Recovery: Repressuring
 Waterflood
 Tertiary

Date: August 28, 2019

Operator License Number: 32218

Operator: TDR Construction, Inc.

Address: PO Box 339
Louisburg, KS 66053

Contact Person: Lance Town

Phone: 913-710-5400

Email: N/A

Permit Number: E - 18352

API Number: 15-059-23585-00-00

Well Location

 - NW - SE - SW Sec. 29 Twp. 15 S. R. 21 E W

996 feet from N / S Line of Section

3876 feet from E / W Line of Section

GPS Location: Lat: 38.712224, Long: -95.106149
(e.g. xx.xxxxx) (e.g. -xxx.xxxxx)

Datum: NAD27 NAD83 WGS84

Lease Description: SW/4 of the Sec.29 Twp.15S R.21E

Lease Name: Moldenhauer Well Number: 30

Field Name: Paola-Rantoul

County: Franklin

Deepest Usable Water

Formation: N/A

Depth to Bottom of Formation: 200'

Received
KANSAS CORPORATION COMMISSION

Check One: Old Well Being Converted Newly Drilled Well Well to be Drilled

Surface Elevation: 1050' feet Well Total Depth: 805' feet Plug Back Depth: N/A feet

Datum of top of injection formation: 764 feet (reference mean sea level)

AUG 30 2019
CONSERVATION DIVISION
WICHITA, KS

Injection Formation Description:

Name	top / bottom	perf / open hole	depth
<u>Squirrel</u>	<u>764</u> / <u>783</u>	<u>perf.</u>	at <u>764</u> to <u>783</u> feet
_____	_____ / _____	_____	at _____ to _____ feet

List of Wells/Facilities Supplying Produced Saltwater or Other Fluids Approved by the Conservation Division:
(attach additional sheets if necessary)

Lease Operator	Lease/Facility Name	Lease/Facility Description	Well ID & Spot Location
<u>1. TDR Construction, Inc.</u>	<u>Moldenhauer Lease</u>	<u>Sec.29/32T.15R.21E</u>	<u>See attached</u>
<u>2. _____</u>	<u>_____</u>	<u>_____</u>	<u>_____</u>
<u>3. _____</u>	<u>_____</u>	<u>_____</u>	<u>_____</u>

Producing Formation	Strata Depth	Total Dissolved Solids (if available)
<u>1. Squirrel</u>	<u>738</u> to <u>752</u> feet	<u>_____</u> mg/l
<u>2. _____</u>	<u>_____</u> to <u>_____</u> feet	<u>_____</u> mg/l
<u>3. _____</u>	<u>_____</u> to <u>_____</u> feet	<u>_____</u> mg/l

Maximum Requested Liquid Injection Rate: 40 bbls / day, or

Maximum Requested Gas Injection Rate: N/A scf / day. Type of Gas: _____

Maximum Requested Injection Pressure: 650 psig

Well Inventory According to the KCC
TDR Construction, Inc.

Lease Name	Well No.	API Number	Year Drilled	Year Assured	Depth	County	Sec	Twp	Rge	Dir	Q4	Q3	Q2	Q1	Feet N-S	N-S	Feet E-W	E-W	Well Type	Well Status	Oil Lease #	Latitude	Longitude	Datum
MOLDENHAUER	14	15-059-19202-0000			765	Franklin	29	15	21	E	SW	SE	SE	SW	237 S		3282 E		OIL	PR	100541	38.71006	-95.105	NAD27
MOLDENHAUER	15	15-059-20319-0000			800	Franklin	29	15	21	E	SW	NE	SW	SW	680 S		4552 E		OIL	PR	100541	38.71114	-95.1094	NAD27
MOLDENHAUER	16	15-059-20320-0000			792	Franklin	29	15	21	E	NE	SE	SE	SW	365 S		4233 E		OIL	PR	100541	38.71042	-95.1084	NAD27
MOLDENHAUER	17	15-059-20321-0000			776	Franklin	29	15	21	E		SW	SE	SW	365 S		3591 E		OIL	PR	100541	38.71042	-95.1063	NAD27
MOLDENHAUER	18 B	15-059-23946-0000			780	Franklin	29	15	21	E		SE	SW	SW	43 S		4095 E		OIL	PR	100541	38.70994	-95.1067	NAD27
MOLDENHAUER	19	15-059-19203-0000			800	Franklin	29	15	21	E	NE	NE	SW	SW	1002 S		4204 E		OIL	PR	100541	38.7121	-95.1082	NAD27
MOLDENHAUER	2	15-059-19197-0000			761	Franklin	29	15	21	E	SE	NW	SW	SW	674 S		4818 E		OIL	PR	100541	38.71127	-95.1103	NAD27
MOLDENHAUER	21	15-059-20666-0000			780	Franklin	29	15	21	E	NE	SW	SW	SW	377 S		4837 E		OIL	PR	100541	38.70995	-95.1114	NAD27
MOLDENHAUER	22	15-059-20790-0000			771	Franklin	29	15	21	E	NW	SW	SW	SW	407 S		5113 E		OIL	PR	100541	38.7104	-95.1114	NAD27
MOLDENHAUER	23	15-059-20791-0000			733	Franklin	29	15	21	E	SE	SW	SW	SW	55 S		4870 E		OIL	PR	100541	38.70995	-95.1102	NAD27
MOLDENHAUER	24	15-059-21231-0000			732	Franklin	32	15	21	E	NE	NW	NW	NW	5050 S		4904 E		OIL	PR	100541	38.70903	-95.1102	NAD27
MOLDENHAUER	3	15-059-19198-0000			753	Franklin	29	15	21	E	SE	NE	SW	SW	674 S		4214 E		OIL	PR	100541	38.71127	-95.1082	NAD27
MOLDENHAUER	39	15-059-25152-0000	2006		800	Franklin	29	15	21	E	SW	SW	SW	SW	49 S		5104 E		OIL	PR	100541	38.70904	-95.1114	NAD27
MOLDENHAUER	4	15-059-19199-0000			748	Franklin	29	15	21	E	SW	NW	SE	SW	674 S		3886 E		OIL	PR	100541	38.71127	-95.1071	NAD27
MOLDENHAUER	40	15-059-25146-0000	2006		810	Franklin	29	15	21	E	SW	NW	SW	SW	693 S		5113 E		OIL	PR	100541	38.71085	-95.1114	NAD27
MOLDENHAUER	41	15-059-25147-0000	2006		802	Franklin	29	15	21	E	NW	NW	SW	SW	1020 S		5103 E		OIL	PR	100541	38.71175	-95.1114	NAD27
MOLDENHAUER	42	15-059-25148-0000	2006		800	Franklin	29	15	21	E	SE	NW	SW	SW	996 S		4851 E		OIL	PR	100541	38.71175	-95.1102	NAD27
MOLDENHAUER	43	15-059-25240-0000	2007		802	Franklin	29	15	21	E		NE	SW	SW	1026 S		4547 E		OIL	PR	100541	38.71211	-95.1097	NAD27
MOLDENHAUER	44	15-059-25241-0000	2007		822	Franklin	29	15	21	E		NE	SW	SW	1281 S		4195 E		OIL	PR	100541	38.71292	-95.1087	NAD27
MOLDENHAUER	47	15-059-25300-0000	2008		822	Franklin	29	15	21	E	NE	NW	SE	SW	1275 S		3539 E		OIL	PR	100541	38.71292	-95.1066	NAD27
MOLDENHAUER	48	15-059-25301-0000	2008		798	Franklin	29	15	21	E	NW	NW	SE	SW	1281 S		3867 E		OIL	PR	100541	38.71292	-95.1076	NAD27
MOLDENHAUER	5	15-059-19200-0000			769	Franklin	29	15	21	E	SE	NW	SE	SW	674 S		3596 E		OIL	PR	100541	38.71127	-95.1061	NAD27
MOLDENHAUER	52	15-059-25309-0000	2008		835	Franklin	29	15	21	E	SW	SE	NW	SW	1324 S		4495 E		OIL	PR	100541	38.713	-95.1097	NAD27
MOLDENHAUER	53	15-059-25310-0000	2008		820	Franklin	29	15	21	E		SE	NW	SW	1597 S		4461 E		OIL	PR	100541	38.71394	-95.1097	NAD27
MOLDENHAUER	54	15-059-25311-0000	2008		836	Franklin	29	15	21	E	SE	SE	NW	SW	1597 S		4200 E		OIL	PR	100541	38.71394	-95.1087	NAD27
MOLDENHAUER	55	15-059-25312-0000	2008		816	Franklin	29	15	21	E		SE	NW	SW	1907 S		4171 E		OIL	PR	100541	38.71487	-95.1087	NAD27
MOLDENHAUER	56	15-059-25323-0000	2008		872	Franklin	29	15	21	E	NW	SE	NW	SW	1931 S		4456 E		OIL	PR	100541	38.71487	-95.1097	NAD27
MOLDENHAUER	57	15-059-25324-0000	2008		817	Franklin	29	15	21	E		SW	NW	SW	1536 S		4804 E		OIL	PR	100541	38.71394	-95.1108	NAD27
MOLDENHAUER	6	15-059-19201-0000			784	Franklin	29	15	21	E		NW	SE	SW	680 S		3310 E		OIL	PR	100541	38.71127	-95.1053	NAD27

Received
 KANSAS CORPORATION COMMISSION
AUG 30 2019
 CONSERVATION DIVISION
 WICHITA, KS

Well Completion

Type: Tubing & Packer Packerless Tubingless

	Conductor	Surface	Intermediate	Production	Tubing
Size	N/A	6 1/4"	N/A	2 1/2"	N/A
Setting Depth	N/A	21'	N/A	805'	N/A
Amount of Cement	N/A	4sx	N/A	140sx	N/A
Top of Cement	N/A	0	N/A	0	N/A
Bottom of Cement	N/A	21'	N/A	805'	N/A

If Alternate II cementing, complete the following:

Perforations / D.V. Tool at N/A feet, cemented to N/A feet with N/A sx.

Tubing: Type N/A Grade N/A

Packer: Type N/A Depth N/A

Annulus Corrosion Inhibitor: Type N/A Concentration N/A

List Logs Enclosed: N/A

Well Sketch

(To sketch installation, darken the appropriate lines, indicate cement, and show depths.)

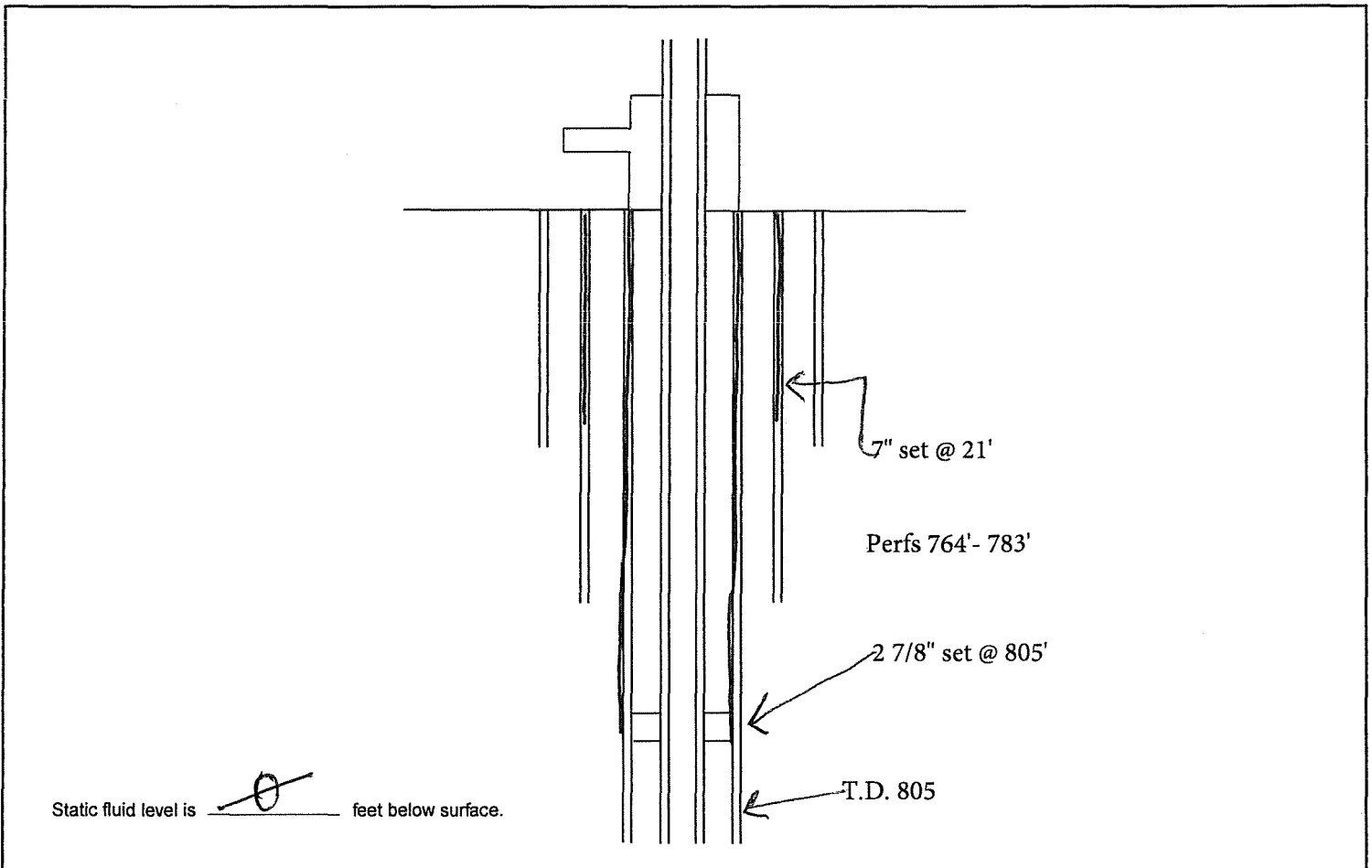

Offset Operators, Unleased Mineral Owners and Landowners acreage

(Attach additional sheets if necessary)

Name:

Legal Description of Leasehold:

See attached listing from county appraiser office

See attached map/list of offset operators per KGS

Received
KANSAS CORPORATION COMMISSION

AUG 30 2019

CONSERVATION DIVISION
WICHITA, KS

I hereby certify that the statements made herein are true and correct to the best of my knowledge and belief.

[Signature]
Applicant or Duly Authorized Agent

Subscribed and sworn before me this 28 day of August, 2019

[Signature]
Notary Public

My Commission Expires: 11-3-19

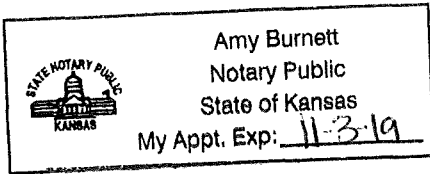

Instructions:

1. Fully complete application, including page 4 (*plat map*) showing subject well and all known oil, gas and input wells, including wells being drilled, inactive wells, or dry holes, within one-half mile. Show lease names and operators or unleased mineral rights owners of all lands within one-half mile. Show well numbers and elevations of producing formation tops.
2. Attach some type of log (*drillers log, electric log, etc.*).
3. Attach some type of verification of cementing for surface casing, longstring, D.V. tool, perforations, etc. (*Cement ticket and job log, bond log, etc.*)
4. Attach Affidavit of Notice.
5. Fill in schematic drawing of subsurface facilities including: size, setting depth, amount of cement, measured or calculated tops of cement for each of surface, intermediate (*if any*) and production casing; size and setting depth of tubing and packer; geological zone of injection showing top and bottom of injection interval.
6. The original and one copy of the application and all attachments shall be mailed to the State Corporation Commission, Conservation Division.
7. Deliver or mail one (1) copy of the application to the landowner on whose land the injection well is located and to each operator or lessee of record and each unleased mineral rights owner within one-half mile of the applicant well.
8. Approval of this application, if granted, is valid only as long as there are no substantial changes in operation set forth in the application. A substantial change requires the approval of a new application. **No injection well may be used without prior written authorization.**
9. All application fees must accompany the application.

Plat and Certificate of Injection Well Location and Surrounding Acreages

Operator: TDR Construction, Inc. Location of Well: SW/4 of the Sec.29 Twp.15S R.21E
 Lease: Moldenhauer Lease 996 feet from N / S Line of Section
 Well Number: Moldenhauer 30 3876 feet from E / W Line of Section
 County: Franklin Sec. 29 Twp. 15 S. R. 21 East West

Plat

Show the following information: applicant injection well, all producing wells, inactive wells, plugged wells, and other wells within a one-half mile radius, all lease boundaries, lease operators, unleased mineral rights owners, well numbers, and producing wells producing formation tops.

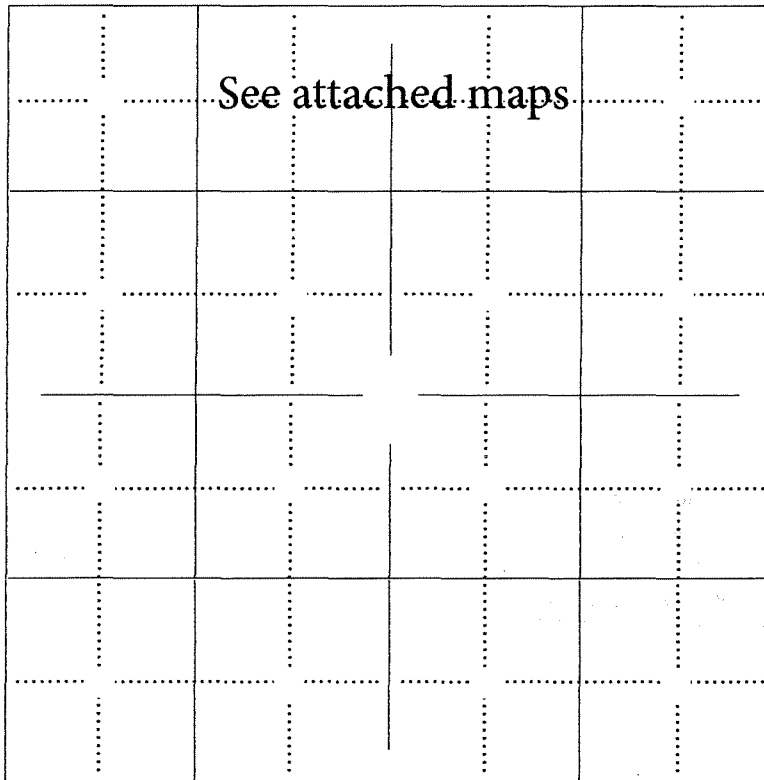

- applicant well
- producing well
- plugged injection well
- D & A well
- other injection well
- temporary abandoned well
- plugged producer
- water supply well

The undersigned hereby certifies that he / she is a duly authorized agent for TDR Construction, Inc. and that all of the information shown herein is true, complete and correct to the best of his / her knowledge.

Juan Baker
 Applicant or Duly Authorized Agent

Subscribed and sworn before me this 28 day of August, 2019

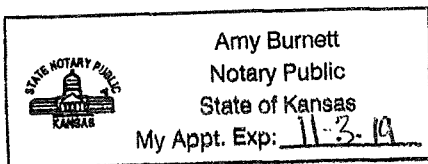

Amy Burnett
 Notary Public
 My Commission Expires: 11-3-19

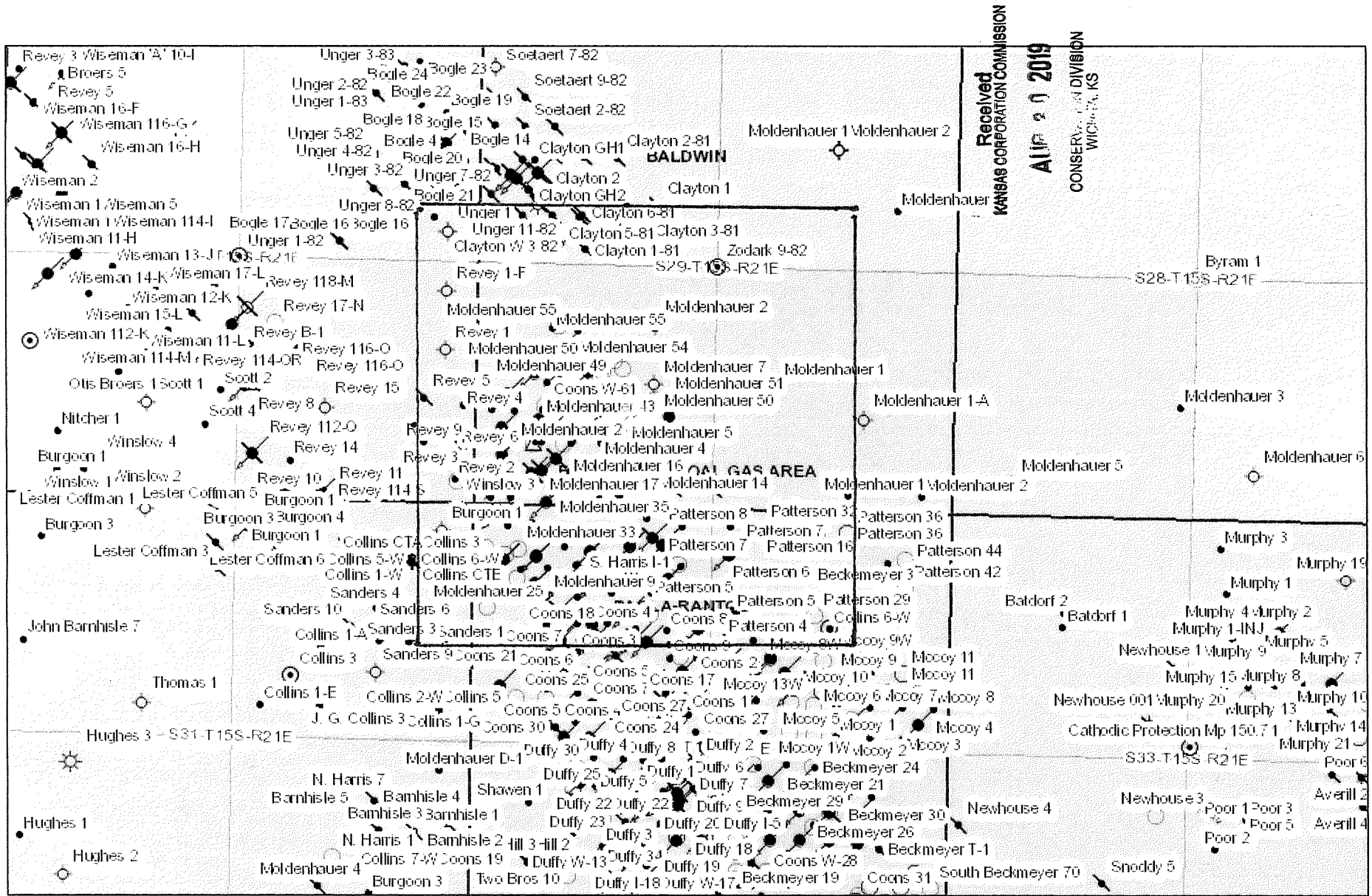

Received
KANSAS CORPORATION COMMISSION

April 9, 2019

CONSERVATION DIVISION
WICHITA, KS

July 30, 19

Haas Petroleum, LLC.

1:18,056

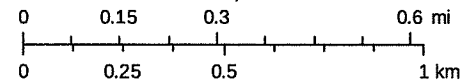

Sources: Esri, HERE, Garmin, Intermap, increment P Corp., GEBCO, USGS, FAO, NPS, NRCAN, GeoBase, IGN, Kadaster NL, Ordnance Survey, Esri

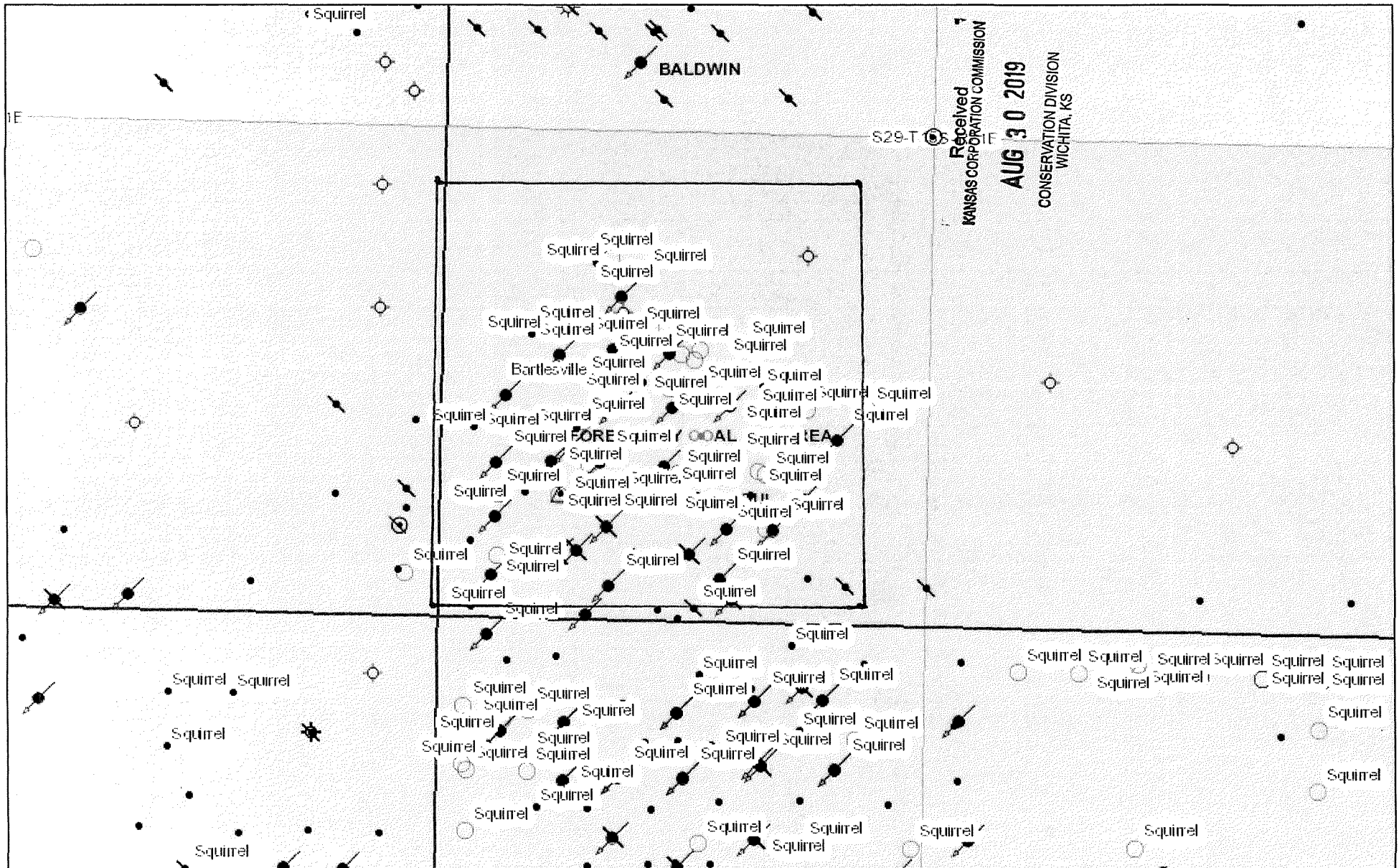

July 30, 19

Squirrel Formation
 Top - 729
 Bottom - 762

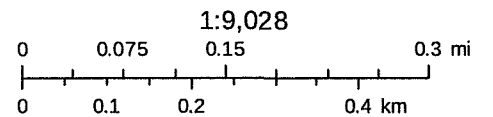

Sources: Esri, HERE, Garmin, Intermap, increment P Corp., GEBCO, USGS, FAO, NPS, NRCAN, GeoBase, IGN, Kadaster NL, Ordnance Survey, Esri

Kansas Geological Survey
<http://www.kgs.ku.edu/index>

Affidavit of Notice Served

Re: Application for: TDR Construction, Inc.

Well Name: Moldenhauer 30 Legal Location: SW/4 of the Sec.29 Twp.15S R.21E

The undersigned hereby certifies that he / she is a duly authorized agent for the applicant, and that on the day 28 of August, 2019, a true and correct copy of the application referenced above was delivered or mailed to the following parties:

Note: A copy of this affidavit must be served as a part of the application.

Name

Address (Attach additional sheets if necessary)

See attached listing from county appraiser office

Received
KANSAS CORPORATION COMMISSION
AUG 30 2019
CONSERVATION DIVISION
WICHITA, KS

I further attest that notice of the filing of this application was published in the Ottawa Herald, the official county publication of Franklin county. A copy of the affidavit of this publication is attached.

Signed this 28 day of August, 2019

[Signature]
Applicant or Duly Authorized Agent

Subscribed and sworn to before me this 28 day of August, 2019

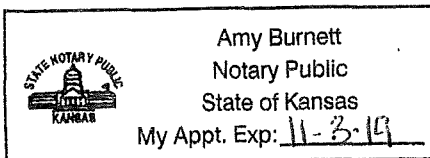

[Signature]
Notary Public

My Commission Expires: 11-3-19

Protests may be filed by any party having a valid interest in the application. Petitions for protests shall be in writing and shall clearly identify the name and address of the protestant and the title of the application. The petition shall include a clear and concise statement of the direct and substantial interest of the protestant in the proceedings, including the manner in which the protestant may be affected, and the nature, extent, character and grounds of the protest. Protestants shall serve the protest upon the applicant by mail or personal service at the same time or before the protestant files the protest with the Conservation Division. Protests must be filed within 30 days of the publication notice of the application.

R306427	FRA0097H	REESE, CALEB R & WENDY E	4495 UTAH RD	WELLSVILLE	KS	66092-8837	29	15	21E	S28, T15, R21E, ACRES 29.6, TR BEG SW/4 SW/4 N50 ELY1360.9 N1364.7 E956.8 S3110.4 SWLY1097.1 W1316 TO POB LESS ROW	4495 UTAH RD, Wellsville, KS 66092
R308	FRA0084	SPENCER, KIERSTIN	12608 CEDAR ST	LEANWOOD	KS	66209-3147	28	15	21E	S28, T15, R21E, ACRES 49.6, SW4 N RR ROW EXC M400 E440 SW/4 & EXC W710 LESS ROW	4560 STAFFORD TER, Wellsville, KS 66092
R309	FRA0083	ALTAVISTA ENERGY INC	PO BOX 128	WELLSVILLE	KS	66092-0128	28	15	21E	S28, T15, R21E, ACRES 6.4, TR BEG SW/4 NW/4 N232 ELY AIG OLD RR ROW 738.1 S568.7 W669.6 TO POB LESS ROW	4515 STAFFORD TER, Wellsville, KS 66092
R312	FRA0084A	DUERINGER TRUST	4547 STAFFORD RD	WELLSVILLE	KS	66092-8867	28	15	21E	WALNUT ESTATES (28-15-21), Lot 1, ACRES 6.2, SECTION 28 TOWNSHIP 15 RANGE 21E	4533 STAFFORD RD, Wellsville, KS 66092
R314	FRA0084A2	DUERINGER TRUST	4547 STAFFORD RD	WELLSVILLE	KS	66092-8867	28	15	21E	WALNUT ESTATES (28-15-21), Lot 2, ACRES 6.1, SECTION 28 TOWNSHIP 15 RANGE 21E	4547 STAFFORD RD, Wellsville, KS 66092
R315	FRA0084B	SPEER, DONNIE J & GAYLA R	4508 STAFFORD TER	WELLSVILLE	KS	66092-8777	28	15	21E	S28, T15, R21E, ACRES 11.3, TR BEG NW/4 SW/4 E710 S732.1 W710 N732.1 TO POB LESS ROW	4508 STAFFORD TER, Wellsville, KS 66092
R316	FRA0084B1	REESE, STEVEN D & JANICE R	4513 STAFFORD RD	WELLSVILLE	KS	66092-8867	28	15	21E	S28, T15, R21E, ACRES 5.7, TR BEG S35E SW/4 SW/4 N100 W191 684 N184.7 E100.5 N553.7 W227.5 NELYS13.6 S1053.9 W265 TO POB LESS ROW	4517 STAFFORD RD, Wellsville, KS 66092
R317	FRA0084B2	REESE, STEVEN D & JANICE R	4513 STAFFORD RD	WELLSVILLE	KS	66092-8867	28	15	21E	S28, T15, R21E, ACRES 4.1, W210 SW/4 SW/4 S RR ROW LESS ROW	4505 STAFFORD RD, Wellsville, KS 66092
R318	FRA0084C	FOSTER TRUST	4482 STAFFORD TER	WELLSVILLE	KS	66092-8776	28	15	21E	S28, T15, R21E, ACRES 13.2, W710 S/4 N RR ROW EXC N732.1	4500 STAFFORD TER, Wellsville, KS 66092
R319	FRA0084B3	REESE, STEVEN D & JANICE R	4513 STAFFORD RD	WELLSVILLE	KS	66092-8867	28	15	21E	S28, T15, R21E, ACRES 4.8, TR BEG 220E SW/4 SW/4 N885 E227.1 S551.7 W100.5 S184.4 S100 W225 TO POB LESS ROW	4513 STAFFORD RD, Wellsville, KS 66092
R320	WEL0055	WELLSVILLE, CITY OF	PO BOX 455	WELLSVILLE	KS	66092-0455	28	15	21E	S28, T15, R21E, ACRES 35.9, TR BEG SE/4 SW/4 W474 N382.2 W750.8 N465 W676.4 N247.9 NELV 2025 S467.9 W193 S564 E193 S486 TO POB LESS ROW	844 WALNUT, Wellsville, KS 66092
R805	WCM0052	NORTH STAR HOUSING LLC	31711 E PINK HILL RD	GRAIN VALLEY	MO	64029-9298	28	15	21E	WALNUT CREEK MEADOWS 1 OR 2, Lot A, ACRES 10.5, SECTION 28 TOWNSHIP 15 RANGE 21E	422 DOUGLAS, Wellsville, KS 66092

Received
KANSAS CORPORATION COMMISSION

AUG 30 2019

CONSERVATION DIVISION
WICHITA, KS

FILED FOR RECORD
TIME 11:35 AM

msd. AUG 05 2019
Book 290 Page 809 4
REGISTER OF DEEDS, FRANKLIN CO., KS
INSTRUMENT # 2440
4 2100

(Original compared with record)

AREA PERMIT

Received
KANSAS CORPORATION COMMISSION

NOTICE OF ENHANCED RECOVERY PROJECT

AUG 30 2019

CONSERVATION DIVISION
WICHITA, KS

Kansas Corporation Commission Docket Number: E - 18352

Project Operator: TDR Construction, Inc.

Legal Description of Project: North Moldenhauer The West 140 Acres of the Southwest Quarter (SW/4) of Section 29, Township 15 South, Range 21 East, except A.T.S.F. Railroad Right-of Way AND that part of Lot 2 in Section 32, Township 15 South, Range 21 East, according to the Government Survey, lying North of the aforesaid rail road right of way.

Maximum Approved Injection Rate: 40 bbls/day

Maximum Approved Injection Pressure: 650 psig

Injection Formation and Depth: Squirrel Formation – Approximate Depth – 850'

Approximate Number of Injection Wells in Project: 95

No injection wells in project will be located closer to a lease or unit boundary line than is allowed by field rules or general state spacing rules unless further notice is given.

TDR Construction, Inc.
Lance Town

Date: 7-31-19

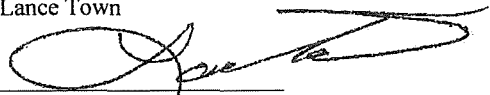
Signature of Operator of Duly
Authorized Agent

STATE OF Kansas)
)ss:
COUNTY OF Miami)

BE IT REMEMBERED that on this 31 day of July, 2019, before me, the undersigned, a Notary Public, duly commissioned, in and for the county and state aforesaid, came Lance Town president of TDR Construction, Inc., a corporation of the State of Kansas, personally known to me to be such officer, and to be the same person who executed as such officer and foregoing instrument of writing on behalf of said corporation, and he duly acknowledged the execution of the same for himself and for said corporation for the uses and purposes therein set forth.

IN WITNESS WHEREOF, I have hereunto set my hand official seal on the day and year last above written.

Amy Burnett
Notary Public

Appointment/Commission Expires:

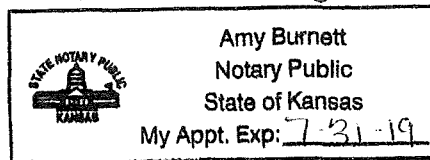

**KANSAS CORPORATION COMMISSION
OIL & GAS CONSERVATION DIVISION
APPLICATION FOR INJECTION WELL**

Form U-1
November 2011
Form must be Typed
Form must be Signed
All blanks must be Filled

Disposal

Enhanced Recovery: Repressuring
 Waterflood
 Tertiary

Date: August 28, 2019

Operator License Number: 32218

Operator: TDR Construction, Inc.

Address: PO Box 339
Louisburg, KS 66053

Contact Person: Lance Town

Phone: 913-710-5400

Email: N/A

Permit Number: E - 18352

API Number: 15-059-25242-00-00

Well Location

NE - NW - SE - SW Sec. 29 Twp. 15 S. R. 21 E W

1002 feet from N / S Line of Section

3529 feet from E / W Line of Section

GPS Location: Lat: 38.71211, Long: -95.106561
(e.g. xx.xxxxx) (e.g. -xxx.xxxxx)

Datum: NAD27 NAD83 WGS84

Lease Description: SW/4 of the Sec.29 Twp.15S R.21E

Lease Name: Moldenhauer Well Number: 45

Field Name: Paola-Rantoul

County: Franklin

Deepest Usable Water

Formation: N/A

Depth to Bottom of Formation: 200'

Received
KANSAS CORPORATION COMMISSION

Check One: Old Well Being Converted Newly Drilled Well Well to be Drilled

Surface Elevation: 1051' feet Well Total Depth: 820' feet Plug Back Depth: N/A feet

Datum of top of injection formation: 757' feet (reference mean sea level)

AUG 30 2019
CONSERVATION DIVISION
WICHITA, KS

Injection Formation Description:

Name	top / bottom	perf / open hole	depth
<u>Squirrel</u>	<u>757</u> / <u>774</u>	<u>perf.</u>	<u>757</u> to <u>774</u> feet
_____	_____ / _____	_____	_____ to _____ feet

List of Wells/Facilities Supplying Produced Saltwater or Other Fluids Approved by the Conservation Division:
(attach additional sheets if necessary)

Lease Operator	Lease/Facility Name	Lease/Facility Description	Well ID & Spot Location
<u>1. TDR Construction, Inc.</u>	<u>Moldenhauer Lease</u>	<u>Sec.29/32T.15R.21E</u>	<u>See attached</u>
<u>2. _____</u>	<u>_____</u>	<u>_____</u>	<u>_____</u>
<u>3. _____</u>	<u>_____</u>	<u>_____</u>	<u>_____</u>

Producing Formation	Strata Depth	Total Dissolved Solids (if available)
<u>1. Squirrel</u>	<u>738</u> to <u>752</u> feet	<u>N/A</u> mg/l
<u>2. _____</u>	_____ to _____ feet	_____ mg/l
<u>3. _____</u>	_____ to _____ feet	_____ mg/l

Maximum Requested Liquid Injection Rate: 40 bbls / day; or

Maximum Requested Gas Injection Rate: N/A scf / day. Type of Gas: _____

Maximum Requested Injection Pressure: 650 psig

Well Inventory According to the KCC
TDR Construction, Inc.

Lease Name	Well No.	API Number	Year Drille	Year Assur	Depth	County	Sec	Twp	Rge	Dir	Q4	Q3	Q2	Q1	Feet N-S	N-S	Feet E-W	E-W	Well Type	Well Statu	Oil Lease (Latitude	Longitude	Datum
MOLDENHAUER	14	15-059-19202-0000			765	Franklin	29	15	21	E	SW	SE	SE	SW	237 S		3282 E		OIL	PR	100541	38.71006	-95.105	NAD27
MOLDENHAUER	15	15-059-20319-0000			800	Franklin	29	15	21	E	SW	NE	SW	SW	680 S		4552 E		OIL	PR	100541	38.71114	-95.1094	NAD27
MOLDENHAUER	16	15-059-20320-0000			792	Franklin	29	15	21	E	NE	SE	SW	SW	365 S		4233 E		OIL	PR	100541	38.71042	-95.1084	NAD27
MOLDENHAUER	17	15-059-20321-0000			776	Franklin	29	15	21	E		SW	SE	SW	365 S		3591 E		OIL	PR	100541	38.71042	-95.1063	NAD27
MOLDENHAUER	18 B	15-059-23946-0000			780	Franklin	29	15	21	E		SE	SW	SW	43 S		4095 E		OIL	PR	100541	38.70994	-95.1067	NAD27
MOLDENHAUER	19	15-059-19203-0000			800	Franklin	29	15	21	E	NE	NE	SW	SW	1002 S		4204 E		OIL	PR	100541	38.7121	-95.1082	NAD27
MOLDENHAUER	2	15-059-19197-0000			761	Franklin	29	15	21	E	SE	NW	SW	SW	674 S		4818 E		OIL	PR	100541	38.71127	-95.1103	NAD27
MOLDENHAUER	21	15-059-20666-0000			780	Franklin	29	15	21	E	NE	SW	SW	SW	377 S		4837 E		OIL	PR	100541	38.70995	-95.1114	NAD27
MOLDENHAUER	22	15-059-20790-0000			771	Franklin	29	15	21	E	NW	SW	SW	SW	407 S		5113 E		OIL	PR	100541	38.71104	-95.1114	NAD27
MOLDENHAUER	23	15-059-20791-0000			733	Franklin	29	15	21	E	SE	SW	SW	SW	55 S		4870 E		OIL	PR	100541	38.70995	-95.1102	NAD27
MOLDENHAUER	24	15-059-21231-0000			732	Franklin	32	15	21	E	NE	NW	NW	NW	5050 S		4904 E		OIL	PR	100541	38.70903	-95.1102	NAD27
MOLDENHAUER	3	15-059-19198-0000			753	Franklin	29	15	21	E	SE	NE	SW	SW	674 S		4214 E		OIL	PR	100541	38.71127	-95.1082	NAD27
MOLDENHAUER	39	15-059-25152-0000	2006		800	Franklin	29	15	21	E	SW	SW	SW	SW	49 S		5104 E		OIL	PR	100541	38.70904	-95.1114	NAD27
MOLDENHAUER	4	15-059-19199-0000			748	Franklin	29	15	21	E	SW	NW	SE	SW	674 S		3886 E		OIL	PR	100541	38.71127	-95.1071	NAD27
MOLDENHAUER	40	15-059-25146-0000	2006		810	Franklin	29	15	21	E	SW	NW	SW	SW	693 S		5113 E		OIL	PR	100541	38.71085	-95.1114	NAD27
MOLDENHAUER	41	15-059-25147-0000	2006		802	Franklin	29	15	21	E	NW	NW	SW	SW	1020 S		5103 E		OIL	PR	100541	38.71175	-95.1114	NAD27
MOLDENHAUER	42	15-059-25148-0000	2006		800	Franklin	29	15	21	E	SE	NW	SW	SW	996 S		4851 E		OIL	PR	100541	38.71175	-95.1102	NAD27
MOLDENHAUER	43	15-059-25240-0000	2007		802	Franklin	29	15	21	E		NE	SW	SW	1026 S		4547 E		OIL	PR	100541	38.71211	-95.1097	NAD27
MOLDENHAUER	44	15-059-25241-0000	2007		822	Franklin	29	15	21	E		NE	SW	SW	1281 S		4195 E		OIL	PR	100541	38.71292	-95.1087	NAD27
MOLDENHAUER	47	15-059-25300-0000	2008		822	Franklin	29	15	21	E	NE	NW	SE	SW	1275 S		3539 E		OIL	PR	100541	38.71292	-95.1066	NAD27
MOLDENHAUER	48	15-059-25301-0000	2008		798	Franklin	29	15	21	E	NW	NW	SE	SW	1281 S		3867 E		OIL	PR	100541	38.71292	-95.1076	NAD27
MOLDENHAUER	5	15-059-19200-0000			769	Franklin	29	15	21	E	SE	NW	SE	SW	674 S		3596 E		OIL	PR	100541	38.71127	-95.1061	NAD27
MOLDENHAUER	52	15-059-25309-0000	2008		835	Franklin	29	15	21	E	SW	SE	NW	SW	1324 S		4495 E		OIL	PR	100541	38.713	-95.1097	NAD27
MOLDENHAUER	53	15-059-25310-0000	2008		820	Franklin	29	15	21	E		SE	NW	SW	1597 S		4461 E		OIL	PR	100541	38.71394	-95.1097	NAD27
MOLDENHAUER	54	15-059-25311-0000	2008		836	Franklin	29	15	21	E	SE	SE	NW	SW	1597 S		4200 E		OIL	PR	100541	38.71394	-95.1087	NAD27
MOLDENHAUER	55	15-059-25312-0000	2008		816	Franklin	29	15	21	E		SE	NW	SW	1907 S		4171 E		OIL	PR	100541	38.71487	-95.1087	NAD27
MOLDENHAUER	56	15-059-25323-0000	2008		872	Franklin	29	15	21	E	NW	SE	NW	SW	1931 S		4456 E		OIL	PR	100541	38.71487	-95.1097	NAD27
MOLDENHAUER	57	15-059-25324-0000	2008		817	Franklin	29	15	21	E		SW	NW	SW	1536 S		4804 E		OIL	PR	100541	38.71394	-95.1108	NAD27
MOLDENHAUER	6	15-059-19201-0000			784	Franklin	29	15	21	E		NW	SE	SW	680 S		3310 E		OIL	PR	100541	38.71127	-95.1053	NAD27

Received
KANSAS CORPORATION COMMISSION
AUG 30 2019
CONSERVATION DIVISION
WICHITA, KS

Well Completion

Type: Tubing & Packer Packerless Tubingless

	Conductor	Surface	Intermediate	Production	Tubing
Size	N/A	7"	N/A	2 7/8"	N/A
Setting Depth	N/A	21'	N/A	814'	N/A
Amount of Cement	N/A	3sx	N/A	121sx	N/A
Top of Cement	N/A	0	N/A	0	N/A
Bottom of Cement	N/A	21'	N/A	814'	N/A

If Alternate II cementing, complete the following:

Perforations / D.V. Tool at N/A feet, cemented to N/A feet with N/A sx.

Tubing: Type N/A Grade N/A

Packer: Type N/A Depth N/A

Annulus Corrosion Inhibitor: Type N/A Concentration N/A

List Logs Enclosed: N/A

Well Sketch

(To sketch installation, darken the appropriate lines, indicate cement, and show depths.)

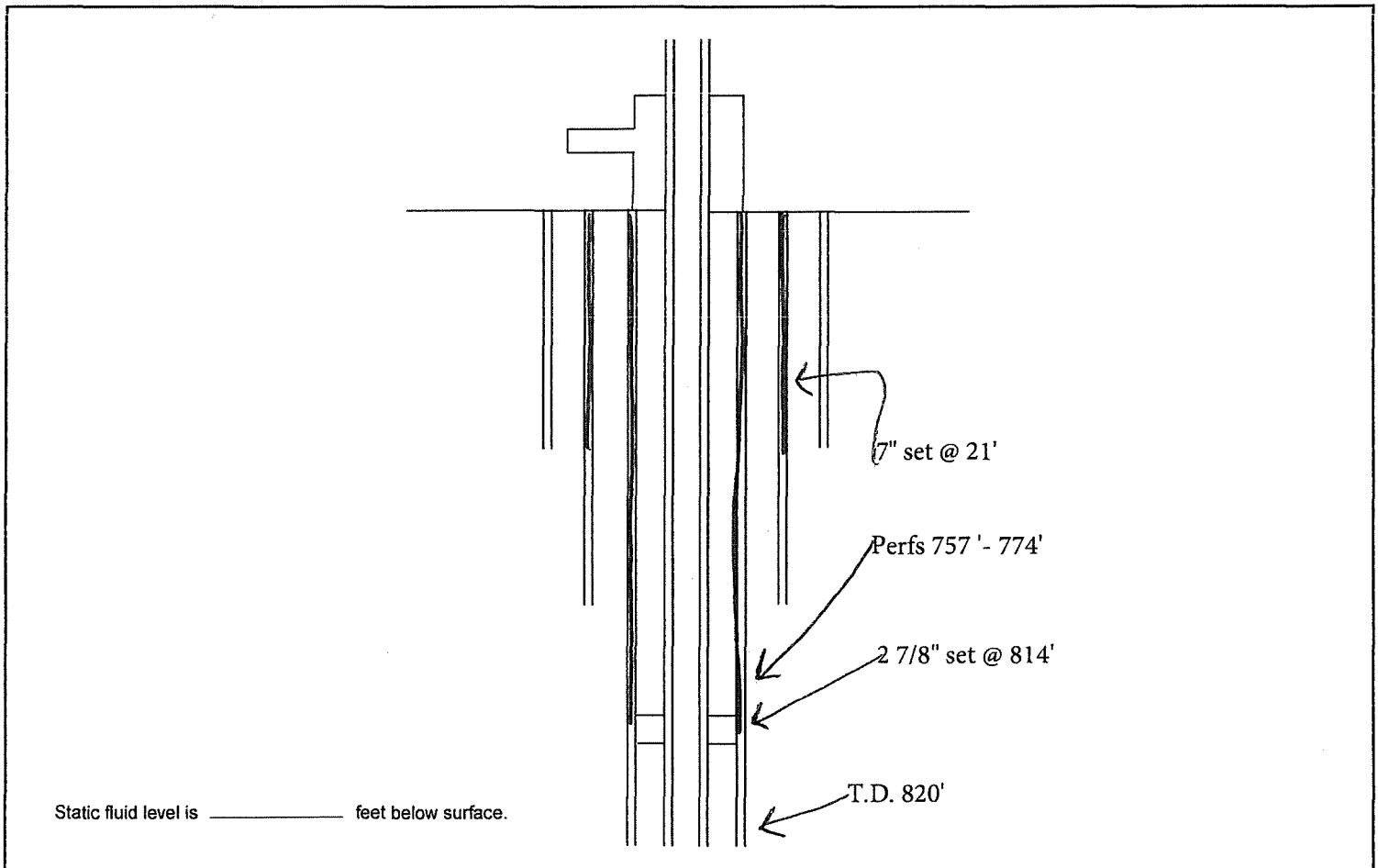

Offset Operators, Unleased Mineral Owners and Landowners acreage

(Attach additional sheets if necessary)

Name:

Legal Description of Leasehold:

See attached listing from county appraiser office

See attached map/list of offset operators per KGS

Received
KANSAS CORPORATION COMMISSION

AUG 30 2019

CONSERVATION DIVISION
WICHITA, KS

I hereby certify that the statements made herein are true and correct to the best of my knowledge and belief.

[Signature]
Applicant or Duly Authorized Agent

Subscribed and sworn before me this 28 day of August, 2019

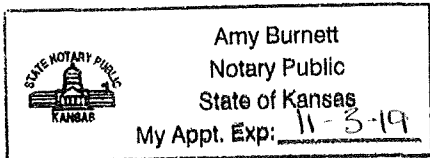

[Signature]
Notary Public
My Commission Expires: 11-3-19

Instructions:

1. Fully complete application, including page 4 (*plat map*) showing subject well and all known oil, gas and input wells, including wells being drilled, inactive wells, or dry holes, within one-half mile. Show lease names and operators or unleased mineral rights owners of all lands within one-half mile. Show well numbers and elevations of producing formation tops.
2. Attach some type of log (*drillers log, electric log, etc.*).
3. Attach some type of verification of cementing for surface casing, longstring, D.V. tool, perforations, etc. (*Cement ticket and job log, bond log, etc.*)
4. Attach Affidavit of Notice.
5. Fill in schematic drawing of subsurface facilities including: size, setting depth, amount of cement, measured or calculated tops of cement for each of surface, intermediate (*if any*) and production casing; size and setting depth of tubing and packer; geological zone of injection showing top and bottom of injection interval.
6. The original and one copy of the application and all attachments shall be mailed to the State Corporation Commission, Conservation Division.
7. Deliver or mail one (1) copy of the application to the landowner on whose land the injection well is located and to each operator or lessee of record and each unleased mineral rights owner within one-half mile of the applicant well.
8. Approval of this application, if granted, is valid only as long as there are no substantial changes in operation set forth in the application. A substantial change requires the approval of a new application. **No injection well may be used without prior written authorization.**
9. All application fees must accompany the application.

Plat and Certificate of Injection Well Location and Surrounding Acreages

Operator: TDR Construction, Inc. Location of Well: SW/4 of the Sec.29 Twp.15S R.21E
 Lease: Moldenhauer Lease 1002 feet from N / S Line of Section
 Well Number: Moldenhauer 45 3529 feet from E / W Line of Section
 County: Franklin Sec. 29 Twp. 15 S. R. 21 East West

Plat

Show the following information: applicant injection well, all producing wells, inactive wells, plugged wells, and other wells within a one-half mile radius, all lease boundaries, lease operators, unleased mineral rights owners, well numbers, and producing wells producing formation tops.

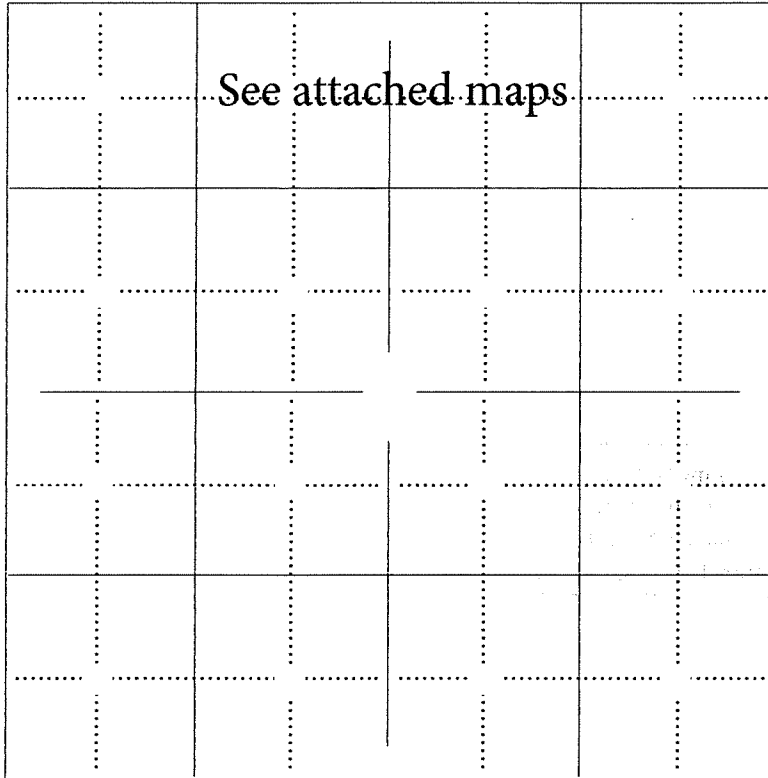

- applicant well
- producing well
- plugged injection well
- D & A well
- other injection well
- temporary abandoned well
- plugged producer
- water supply well

The undersigned hereby certifies that he / she is a duly authorized agent for TDR Construction, Inc. and that all of the information shown herein is true, complete and correct to the best of his / her knowledge.

Jane Baker
 Applicant or Duly Authorized Agent

Subscribed and sworn before me this 28 day of August, 2019

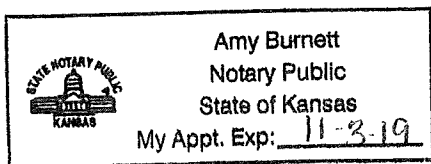

Amy Burnett
 Notary Public
 My Commission Expires: 11-3-19

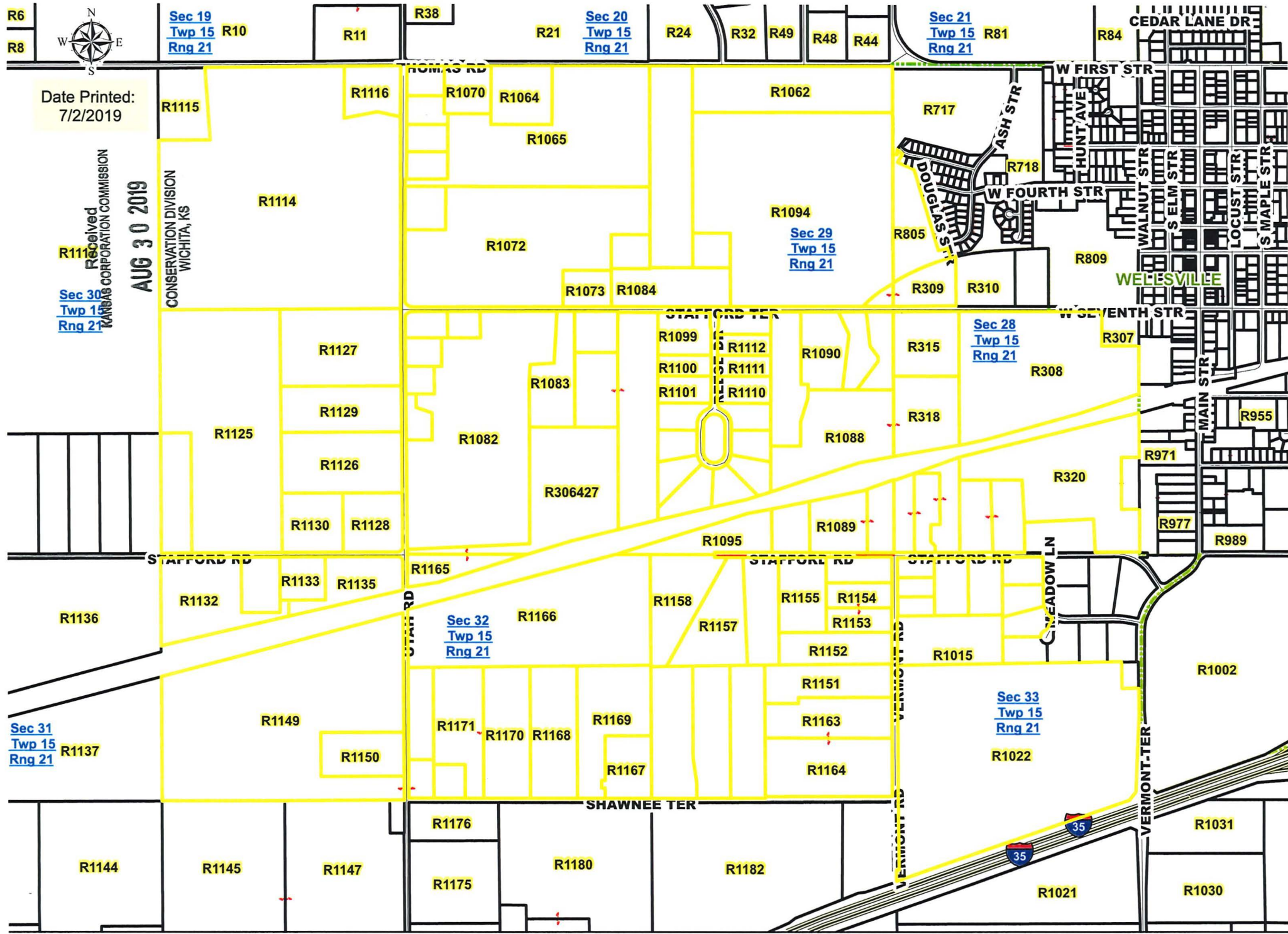

Date Printed:
7/2/2019

Received
 WELLINGTON CORPORATION COMMISSION
 AUG 30 2019
 CONSERVATION DIVISION
 WICHITA, KS

Sec 31
Twp 15
Rng 21

Sec 19
Twp 15
Rng 21

Sec 20
Twp 15
Rng 21

Sec 21
Twp 15
Rng 21

Sec 32
Twp 15
Rng 21

Sec 33
Twp 15
Rng 21

Sec 29
Twp 15
Rng 21

Sec 28
Twp 15
Rng 21

This property ownership map is for appraisal purposes only. It is not intended for conveyances, nor is it a legal survey.

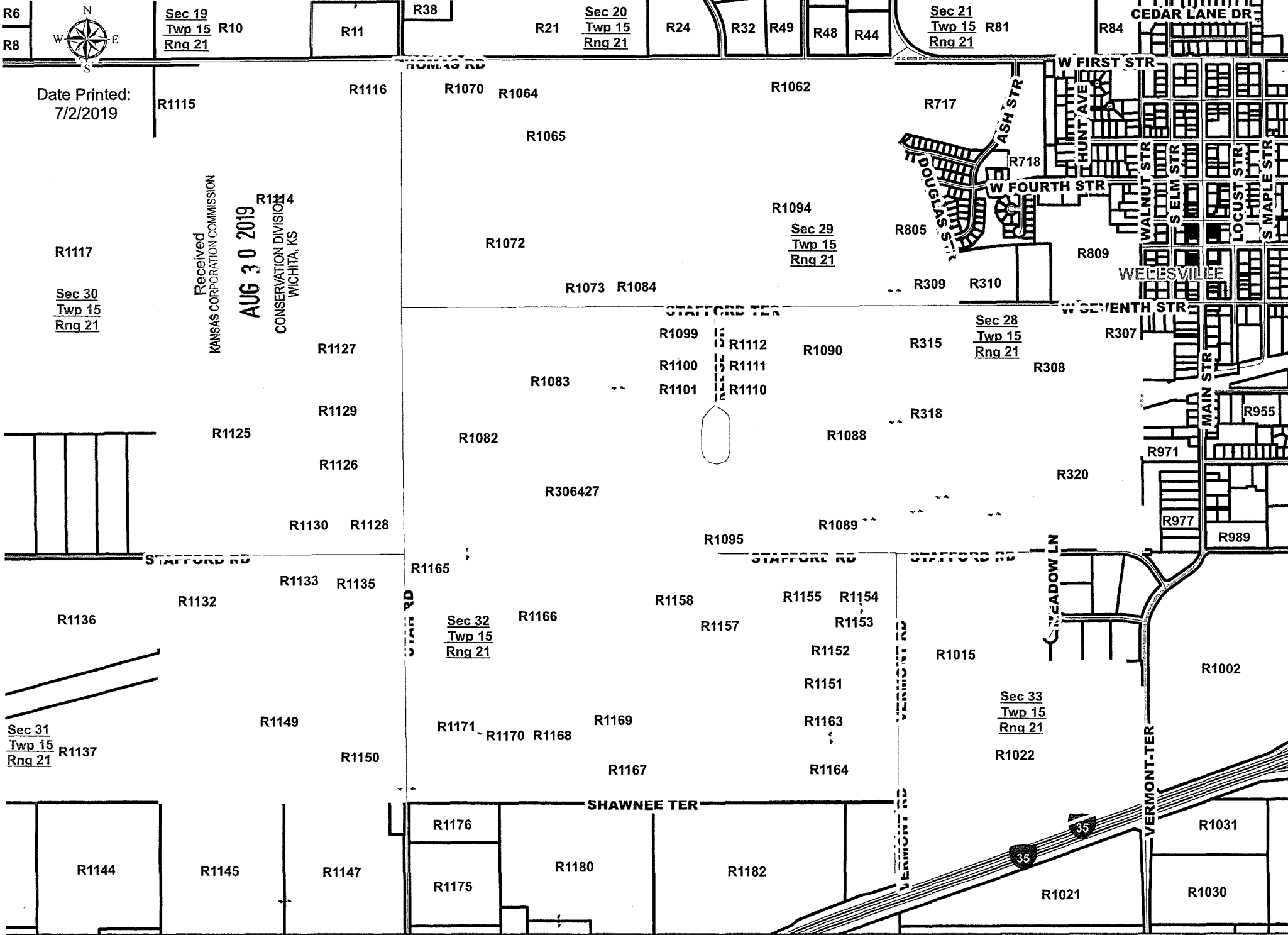

Date Printed:
7/2/2019

Received
KANSAS CORPORATION COMMISSION
AUG 30 2019
CONSERVATION DIVISION
WICHITA, KS

Sec 30
Twp 15
Rng 21

Sec 31
Twp 15
Rng 21

Sec 32
Twp 15
Rng 21

Sec 33
Twp 15
Rng 21

This property ownership map is for appraisal purposes only. It is not intended for conveyances, nor is it a legal survey.

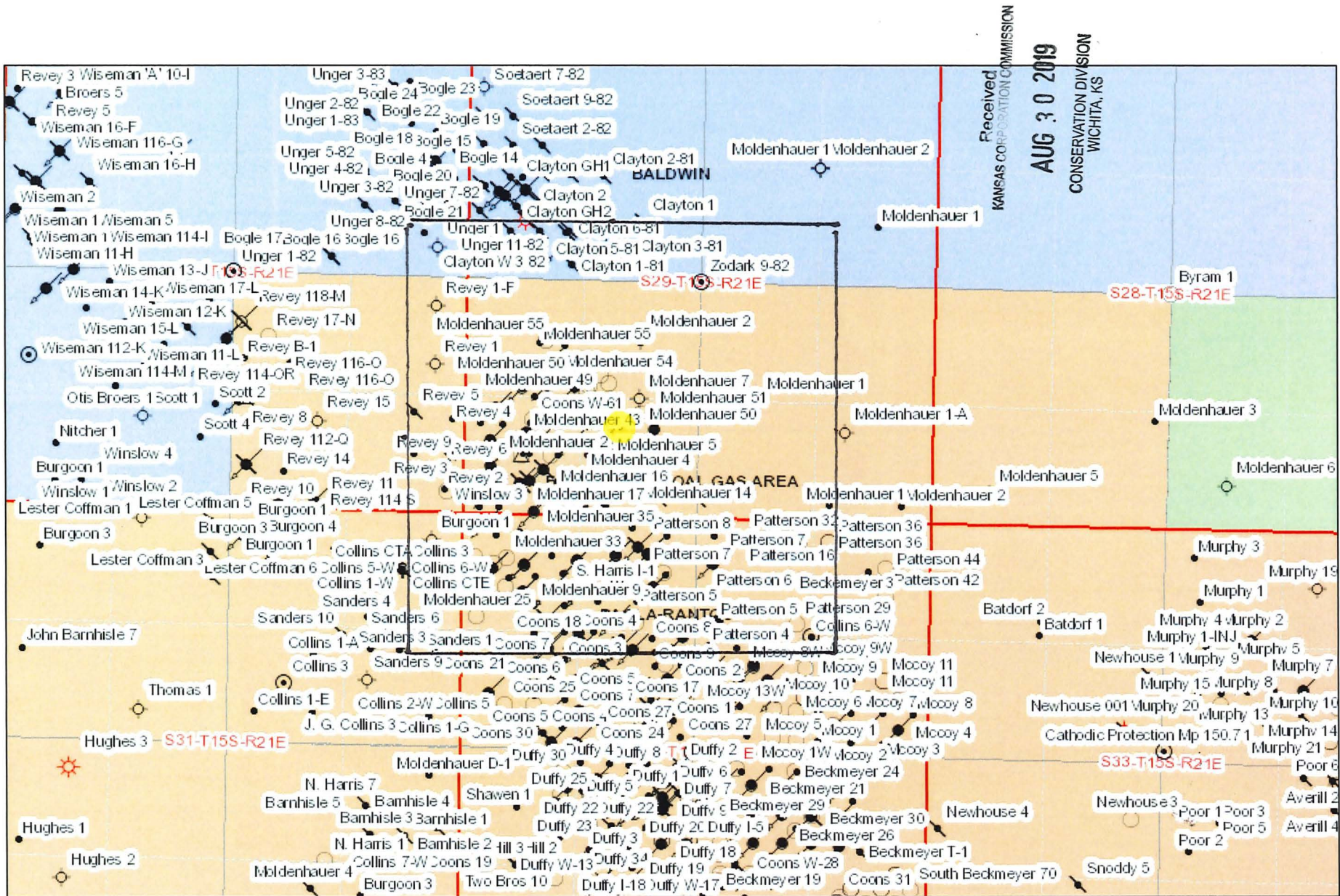

July 30, 19

Haas Petroleum, LLC.

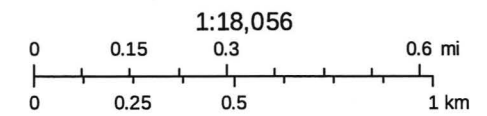

Sources: Esri, HERE, Garmin, Intermap, increment P Corp., GEBCO, USGS, FAO, NPS, NRCAN, GeoBase, IGN, Kadaster NL, Ordnance Survey, Esri

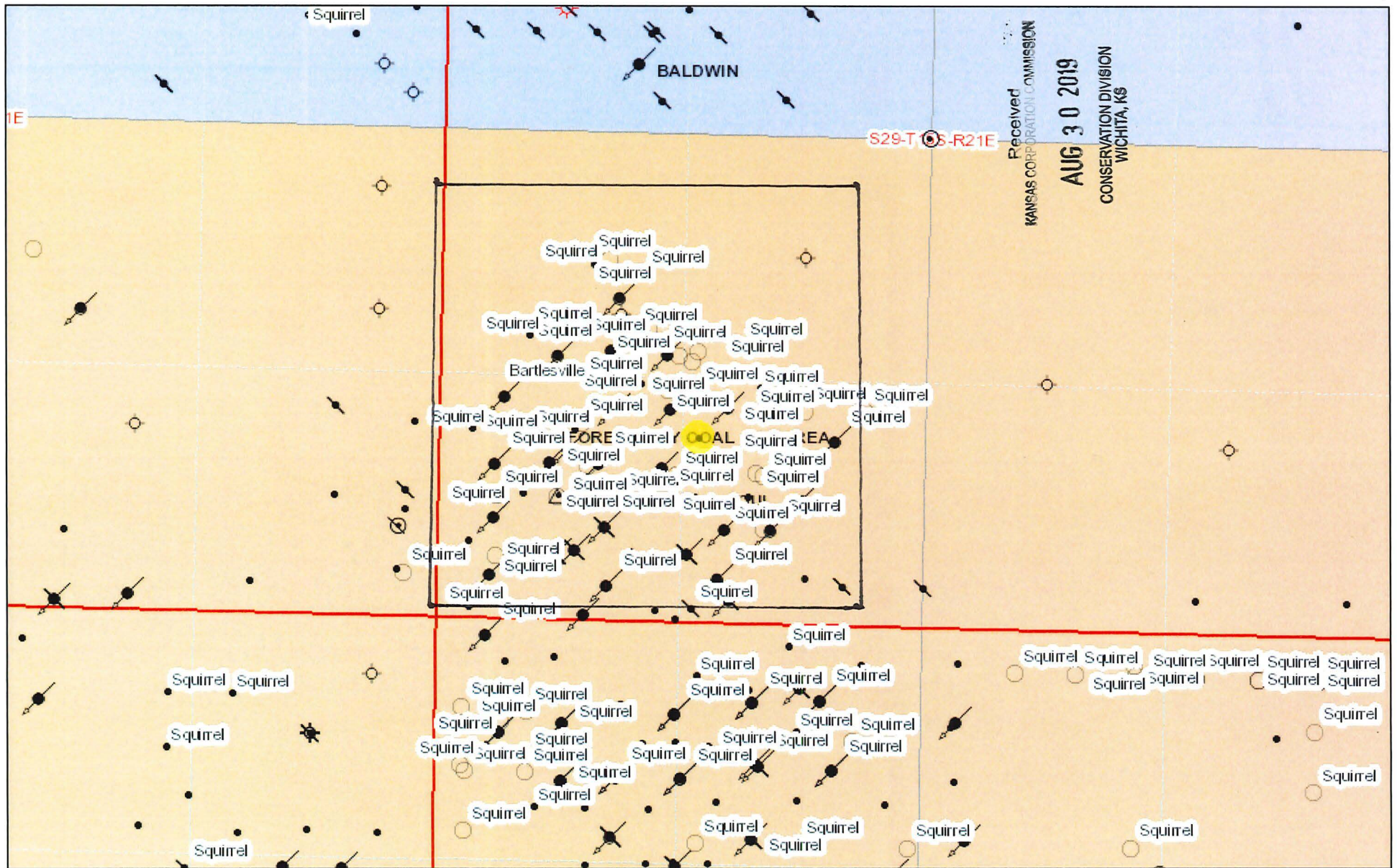

July 30, 19

Squirrel Formation
 Top - 729
 Bottom - 762

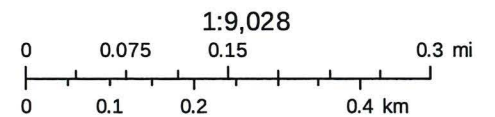

Sources: Esri, HERE, Garmin, Intermap, increment P Corp., GEBCO, USGS, FAO, NPS, NRCAN, GeoBase, IGN, Kadaster NL, Ordnance Survey, Esri

Affidavit of Notice Served

Re: Application for: TDR Construction, Inc.

Well Name: Moldenhauer 45 Legal Location: SW/4 of the Sec.29 Twp.15S R.21E

The undersigned hereby certifies that he / she is a duly authorized agent for the applicant, and that on the day 28 of August, 2019, a true and correct copy of the application referenced above was delivered or mailed to the following parties:

Note: A copy of this affidavit must be served as a part of the application.

Name Address (Attach additional sheets if necessary)

See attached listing from county appraiser office

Received
KANSAS CORPORATION COMMISSION
AUG 30 2019
CONSERVATION DIVISION
WICHITA, KS

I further attest that notice of the filing of this application was published in the Ottawa Herald, the official county publication of Franklin county. A copy of the affidavit of this publication is attached.

Signed this 28 day of August, 2019
[Signature]
Applicant or Duly Authorized Agent

Subscribed and sworn to before me this 28 day of August, 2019

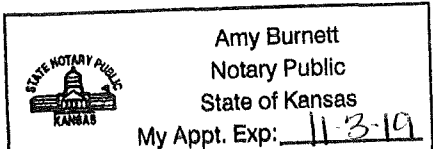
Amy Burnett
Notary Public
State of Kansas
My Appt. Exp: 11-3-19

[Signature]
Notary Public
My Commission Expires: 11-3-19

Protests may be filed by any party having a valid interest in the application. Petitions for protests shall be in writing and shall clearly identify the name and address of the protestant and the title of the application. The petition shall include a clear and concise statement of the direct and substantial interest of the protestant in the proceedings, including the manner in which the protestant may be affected, and the nature, extent, character and grounds of the protest. Protestants shall serve the protest upon the applicant by mail or personal service at the same time or before the protestant files the protest with the Conservation Division. Protests must be filed within 30 days of the publication notice of the application.

R306427	FRA0097H	REESE, CALEB R & WENDY E	4495 UTAH RD	WELLSVILLE	KS	66092-8817	29	15	21E	S29, T15, R21E, Acres 29.6, TR BEG SW/C SW4 NS0 ELY1360.9 N1264.7 E956.8 S1110.4 SWLY1037.1 W1316 TO POB LESS ROW	4495 UTAH RD, Wellsville, KS 66092
R308	FRA0084	SPENCER, KIERSTIN	12608 CEDAR ST	LEAWOOD	KS	66209-3147	28	15	21E	S28, T15, R21E, ACRES 49.6, SW4 N RR ROW EXC N400 E440 SW4 & EXC W710 LESS ROW	4560 STAFFORD TER, Wellsville, KS 66092
R309	FRA0083	ALTAVISTA ENERGY INC	PO BOX 128	WELLSVILLE	KS	66092-0128	28	15	21E	S28, T15, R21E, ACRES 6.4, TR BEG SW/C NW4 N231 ELY ALG OLD RR ROW 738.1 S568.7 W669.6 TO POB LESS ROW	4515 STAFFORD TER, Wellsville, KS 66092
R312	FRA0084A	DUENINGER TRUST	4547 STAFFORD RD	WELLSVILLE	KS	66092-8867	28	15	21E	WALNUT ESTATES (28-15-21), Lot 1, ACRES 6.2, SECTION 28 TOWNSHIP 15 RANGE 21E	4533 STAFFORD RD, Wellsville, KS 66092
R314	FRA0084Z	DUENINGER TRUST	4547 STAFFORD RD	WELLSVILLE	KS	66092-8867	28	15	21E	WALNUT ESTATES (28-15-21), Lot 2, ACRES 6.1, SECTION 28 TOWNSHIP 15 RANGE 21E	4547 STAFFORD RD, Wellsville, KS 66092
R315	FRA0084B	SPEER, DONNIE J & GAYLA R	4508 STAFFORD TER	WELLSVILLE	KS	66092-8777	28	15	21E	S28, T15, R21E, ACRES 11.3, TR BEG NW/C SW4 E710 S732.3 W710 N732.1 TO POB LESS ROW	4508 STAFFORD TER, Wellsville, KS 66092
R316	FRA0084B1	REESE, STEVEN D & JANICE R	4513 STAFFORD RD	WELLSVILLE	KS	66092-8867	28	15	21E	S28, T15, R21E, ACRES 5.7, TR BEG 435E SW/C SW4 N100 NWLY 684 N184.7 E100.5 N551.7 W227.5 NELYS13.6 S1053.9 W265 TO POB LESS ROW	4517 STAFFORD RD, Wellsville, KS 66092
R317	FRA0084B2	REESE, STEVEN D & JANICE R	4513 STAFFORD RD	WELLSVILLE	KS	66092-8867	28	15	21E	S28, T15, R21E, ACRES 4.1, W210 SW4 SW4 S RR ROW LESS ROW	4505 STAFFORD RD, Wellsville, KS 66092
R318	FRA0084C	FOSTER TRUST	4482 STAFFORD TER	WELLSVILLE	KS	66092-8776	28	15	21E	S28, T15, R21E, ACRES 13.2, W710 S/4 N RR ROW EXC N732.1	4500 STAFFORD TER, Wellsville, KS 66092
R319	FRA0084B3	REESE, STEVEN D & JANICE R	4513 STAFFORD RD	WELLSVILLE	KS	66092-8867	28	15	21E	S28, T15, R21E, ACRES 4.8, TR BEG 220E SW/C SW4 N885 E247.1 S551.7 W100.5 S184.7 SELY68.4 S100 W225 TO POB LESS ROW	4513 STAFFORD RD, Wellsville, KS 66092
R320	WEL0055	WELLSVILLE, CITY OF	PO BOX 455	WELLSVILLE	KS	66092-0455	28	15	21E	S28, T15, R21E, ACRES 35.9, TR BEG SE/C SW4 W474 N382.2 W750.8 N465 W676.4 N247.9 NELV 2025 S467.9 W193 S564 E193 S486 TO POB LESS ROW	844 WALNUT, Wellsville, KS 66092
R805	WCM0052	NORTH STAR HOUSING LLC	31711 E PINK HILL RD	GRAIN VALLEY	MO	64029-9298	28	15	21E	WALNUT CREEK MEADOWS 1 OR 2, Lot A, ACRES 10.5, SECTION 28 TOWNSHIP 15 RANGE 21E	422 DOUGLAS, Wellsville, KS 66092

Received
KANSAS CORPORATION COMMISSION

AUG 30 2019
CONSERVATION DIVISION
WICHITA, KS

FILED FOR RECORD
TIME 11:35 AM

msw.
AUG 05 2019
Book 290 Page 809
REGISTER OF DEEDS, FRANKLIN CO., KS
INSTRUMENT # 2440
4 2100

(Original compared with record)

AREA PERMIT

NOTICE OF ENHANCED RECOVERY PROJECT

Received
KANSAS CORPORATION COMMISSION

AUG 30 2019

CONSERVATION DIVISION
WICHITA, KS

Kansas Corporation Commission Docket Number: E - 18352

Project Operator: TDR Construction, Inc.

Legal Description of Project: North Moldenhauer The West 140 Acres of the Southwest Quarter (SW/4) of Section 29, Township 15 South, Range 21 East, except A.T.S.F. Railroad Right-of Way AND that part of Lot 2 in Section 32, Township 15 South, Range 21 East, according to the Government Survey, lying North of the aforesaid rail road right of way.

Maximum Approved Injection Rate: 40 bbls/day

Maximum Approved Injection Pressure: 650 psig

Injection Formation and Depth: Squirrel Formation – Approximate Depth – 850'

Approximate Number of Injection Wells in Project: 95

No injection wells in project will be located closer to a lease or unit boundary line than is allowed by field rules or general state spacing rules unless further notice is given.

TDR Construction, Inc.
Lance Town



Signature of Operator of Duty
Authorized Agent

Date: 7-31-19

STATE OF Kansas)
)ss:
COUNTY OF Wagon)

BE IT REMEMBERED that on this 31 day of July, 2019, before me, the undersigned, a Notary Public, duly commissioned, in and for the county and state aforesaid, came Lance Town president of TDR Construction, Inc., a corporation of the State of Kansas, personally known to me to be such officer, and to be the same person who executed as such officer and foregoing instrument of writing on behalf of said corporation, and he duly acknowledged the execution of the same for himself and for said corporation for the uses and purposes therein set forth.

IN WITNESS WHEREOF, I have hereunto set my hand official seal on the day and year last above written.

Amy Burnett

Notary Public

Appointment/Commission Expires:

